



TM_FLOOR CEILING(GA)_R410A_INV_CE_NA_2109

FLOOR CEILING R410A INVERTER CONTROL

TECHNICAL MANUAL

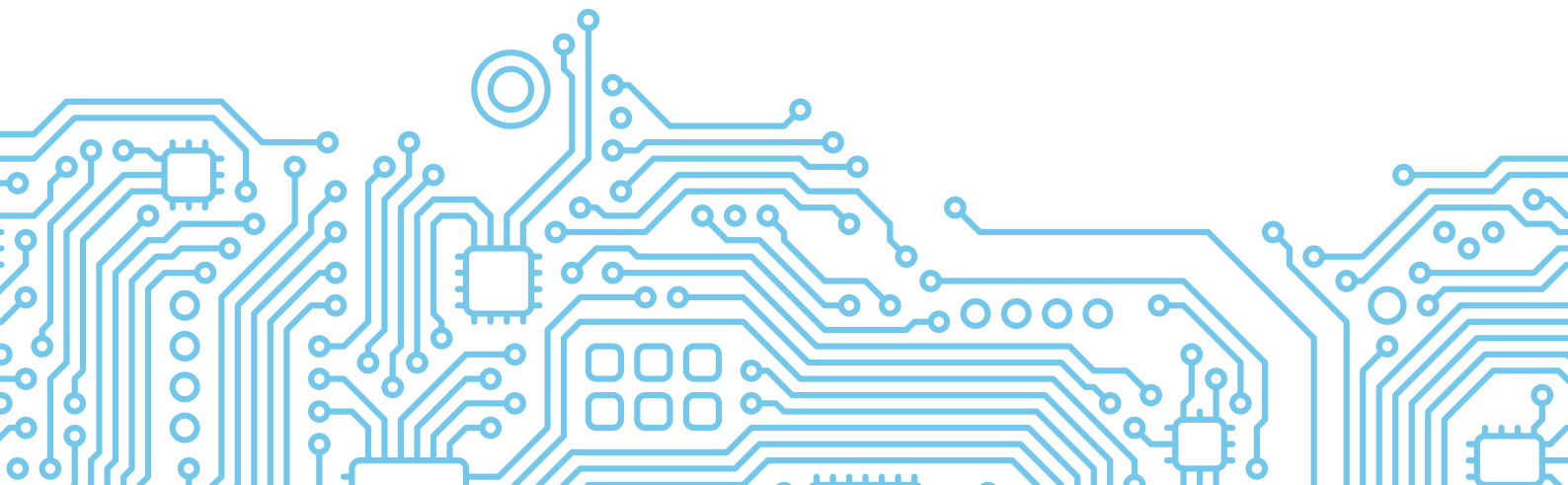
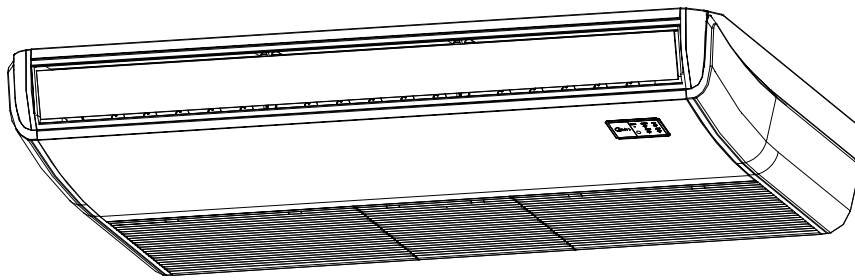

Table of Contents

Page

1. Specifications	4
1. Model Reference	
2. General Specifications	
3. Dimensional Drawings	
4. Electrical Wiring Diagrams	
5. Refrigerant Cycle Diagrams	
6. Air Velocity and Temperature Distributions	
7. Capacity Tables	
8. Capacity Correction Factor for Height Difference	
9. Noise Criterion Curves	
10. Electrical Characteristics	
2. Product Features	77
1. Operation Modes and Functions	
2. Optional Functions	
3. Remote Controller Functions	
3. Installation	110
1. Installation Overview	
2. Location Selection	
3. Indoor Unit Installation	
4. Outdoor Unit Installation	
5. Drainage Pipe Installation	
6. Refrigerant Pipe Installation	
7. Vacuum Drying and Leakage checking	
8. Additional Refrigerant Charge	
9. Engineering of Insulation	

Table of Contents

Page

10. Engineering of Electrical Wiring

11. Test Operation

Specifications

Contents

1.	Model Reference.....	5
2.	General Specifications.....	6
3.	Dimensional Drawings.....	10
4.	Electrical Wiring Diagrams.....	14
5.	Refrigerant Cycle Diagrams.....	24
6.	Air Velocity and Temperature Distributions.....	26
7.	Capacity Tables.....	58
8.	Capacity Correction Factor for Height Difference.....	70
9.	Noise Criterion Curves.....	72
10.	Electrical Characteristics.....	76

1. Model Reference

Refer to the following table to determine the specific indoor and outdoor unit model number of your purchased equipment.

Indoor Unit Model	Outdoor Unit Model	Capacity (Btu/h)	Power Supply
MUE-24HRFNX-QRD0W(GA)	MOX430-24HDN1-QW	24k	1Ph, 220-240V~, 50Hz
MUE-36HRFNX-QRD0W(GA)	MOD30U-36HDN1-RW(GA)	36k	3Ph, 380-415V~, 50Hz
MUE-48HRDN1-QW(GA)	MOD30U-48HDN1-RW(GA)	48k	
MUE-55HRDN1-QW(GA)	MOE30U-55HDN1-RW(GA)	55k	

2. General Specifications

Indoor model		MUE-24HRFNX-QRD0W(GA)	MUE-36HRFNX-QRD0W(GA)
Outdoor model		MOX430-24HDN1-QW	MOD30U-36HDN1-RW(GA)
Power supply (Indoor)		V- Ph-Hz	220-240-1-50
Power Supply (Outdoor)		V-Ph-Hz	220-240-1-50
Rated Power Input		W	3700
Rated Current		A	19
Indoor fan motor	Model		ZKFN-90-8-1
	Qty		1
	Insulation class		E
	IP rating		IPX4
	Output	W	90
	Capacitor	uF	/
	Speed(Hi/Mi/Lo)	r/min	1202/1051/900
Indoor coil	Number of rows		3
	Tube pitch(a)x row pitch(b)	mm	21x13.37
	Fin spacing	mm	1.3
	Fin type (code)		Hydrophilic aluminum
	Tube outside dia.and type	mm	Φ7,Inner groove tube
	Coil length x height x width	mm	795*40.11*294
	Number of circuits		7
Indoor air flow (Hi/Mi/Lo)		m ³ /h	1192/1023/853
Indoor sound pressure level		dB(A)	48/43.7/39.6
Indoor unit	Dimension(W*D*H)	mm	1068x675x235
	Packing (W*D*H)	mm	1145x755x318
	Net/Gross weight	kg	28/33.1
Drainage water pipe diameter		mm	ODΦ25mm
Refrigerant piping	Liquid side/ Gas side	mm(inch)	Φ9.52/Φ15.9(3/8"/5/8")
Controller			Remote Control
Operation temperature		°C	16~30
Room temperature	Cooling	°C	16~32
	Heating	°C	0~30
Qty'per 20' /40' /40'HQ		Indoor unit	102/220/252
Compressor	Model		KTM240D57UMT
	Type		Twin-ROTARY
	Brand		GMCC
	Capacity	W	7740
	Input	W	2085
	Rated current(RLA)	A	9.45
	Refrigerant oil/oil charge	ml	ESTER OIL VG74 670
Outdoor fan motor	Model		YKT-65-6-234-1
	Qty		1
	Insulation class		B
	IP rating		IP24
	Output	W	65
	Capacitor	uF	5
	Capacitor class		S3
Speed		r/min	800/700/580

Outdoor coil	Number of rows		1.6	2
	Tube pitch(a)x row pitch(b)	mm	21x22	25.4x22
	Fin spacing	mm	1.3	1.3
	Fin type (code)		Hydrophilic aluminum	Hydrophilic aluminum
	Tube outside dia.and type	mm	Φ7,Inner groove tube	Φ9.52,Inner groove tube
	Coil length x height x width	mm	900x609x44	995x762x44
	Number of circuits		5	4
Outdoor air flow		m ³ /h	3500	5000
Outdoor sound pressure level		dB(A)	59	60
Throttle type			Throttle valve	Throttle valve
Outdoor unit	Dimension(W*D*H)	mm	890x342x673	946x410x810
	Packing (W*D*H)	mm	995x398x740	1090x500x885
	Net/Gross weight	kg	44/47.3	77.9/82.7
Refrigerant type		kg	R410A/1.9	R410A/3
Design pressure		MPa	4.2/1.5	4.2/1.5
Refrigerant piping	Liquid side/ Gas side	mm(inch)	Φ9.52/Φ15.9(3/8"/5/8")	Φ9.52/Φ15.9(3/8"/5/8")
	Max. refrigerant pipe length	m	25	30
	Max. difference in level	m	15	20
Ambient temperature	Cooling	°C	-15~50	-15~50
	Heating	°C	-15~24	-15~24
Qty'per 20' /40' /40'HQ		Outdoor unit	99/198/198	44/96/138

Notes:

1) Capacities are based on the following conditions:

Cooling(T1): - Indoor Temperature 27°C(80.6°F) DB /19 °C(66.2°F) WB

-Outdoor Temperature 35 °C(95°F) DB /24 °C(75.2°F) WB

-Interconnecting Piping Length 5m

- Level Difference of Zero.

Heating: - Indoor Temperature 20°C(68°F) DB / 15°C(59°F) WB

-Outdoor Temperature 7°C(44.6°F) DB / 6°C(42.8°F) WB

- Interconnecting Piping Length 5 m

- Level Difference of Zero.

2) Capacities are Net Capacities.

3) Due to our policy of innovation some specifications may be changed without notification.

Indoor model			MUE-48HRDN1-QW(GA)	MUE-55HRDN1-QW(GA)
Outdoor model			MOD30U-48HDN1-RW(GA)	MOE30U-55HDN1-RW(GA)
Power supply (Indoor)	V- Ph-Hz		220-240-1-50	220-240-1-50
Power Supply (Outdoor)	V-Ph-Hz		380-415-3-50	380-415-3-50
Rated Power Input	W		6700	7600
Rated Current	A		14	14
Indoor fan motor	Model		YKSS-85-4-1L-2	YKSS-85-4-1L-2
	Qty		2	2
	Insulation class		B	B
	IP rating		IPX0	IPX0
	Output	W	85	85
	Capacitor	uF	2.5	2.5
	Capacitor class		S3	S3
	Speed(Hi/Mi/Lo)	r/min	1280/1220/1145	1300/1230/1160
Indoor coil	Number of rows		3	3
	Tube pitch(a)x row pitch(b)	mm	21x13.37	21x13.37
	Fin spacing	mm	1.3	1.3
	Fin type (code)		Hydrophilic aluminum	Hydrophilic aluminum
	Tube outside dia.and type	mm	Φ7,Inner groove tube	Φ7,Inner groove tube
	Coil length x height x width	mm	1300x294x40.11	1300x294x40.11
	Number of circuits		10	10
Indoor air flow (Hi/Mi/Lo)	m3/h		2300/2170/2000	2340/2180/2020
Indoor sound pressure level	dB(A)		54/52/50	53.5/50.5/49.5
Indoor unit	Dimension(W*D*H)	mm	1650x675x235	1650x675x235
	Packing (W*D*H)	mm	1725x755x318	1725x755x318
	Net/Gross weight	kg	40.4/46.8	40.4/47.0
Drainage water pipe diameter	mm		ODΦ25mm	ODΦ25mm
Refrigerant piping	Liquid side/ Gas side	mm(inch)	Φ9.52/Φ15.9(3/8"/5/8")	Φ9.52/Φ15.9(3/8"/5/8")
Controller			Remote Control	Remote Control
Operation temperature	°C		16~30	16~30
Room temperature	Cooling	°C	16~32	16~32
	Heating	°C	0~30	0~30
Qty'per 20' /40' /40'HQ	Indoor unit		72/147/167	72/147/167
Compressor	Model		KTF310D43UMT	KTQ420D1UMU
	Type		ROTARY	ROTARY
	Brand		GMCC	GMCC
	Capacity	W	10010	13700
	Input	W	2765	3700
	Rated current(RLA)	A	5.38	7.02
	Thermal protector		INT01L-4639	INT01L-4639
	Thermal protector position		EXTERNAL	EXTERNAL
	Refrigerant oil/oil charge	ml	VG74/1000	VG74/1400
Outdoor fan motor	Model		YKS-190-6-21L	YKT-90-6-10
	Qty		1	2
	Insulation class		B	B
	IP rating		IPX4	IPX4
	Output	W	190	90
	Capacitor	uF	10	5
	Capacitor class		P2	S3
	Speed	r/min	850	880/810

Outdoor coil	Number of rows		2.6	1.6
	Tube pitch(a)x row pitch(b)	mm	25.4x22	25.4x22
	Fin spacing	mm	1.5	1.4
	Fin type (code)		Hydrophilic aluminum	Hydrophilic aluminum
	Tube outside dia.and type	mm	Φ9.52,Inner groove tube	Φ9.52,Inner groove tube
	Coil length x height x width	mm	995x762x22+960x762x22+580x762x22	990x1320x22+580x1320x22
	Number of circuits		6	8
Outdoor air flow		m ³ /h	5000	7650
Outdoor sound pressure level		dB(A)	64	63.5
Throttle type			Throttle valve	Throttle valve
Outdoor unit	Dimension(W*D*H)	mm	946x410x810	952x415x1333
	Packing (W*D*H)	mm	1090x500x885	1095x495x1480
	Net/Gross weight	kg	86.7/91.4	107.1/121.3
Refrigerant type		kg	R410A/3.65	R410A/4
Design pressure		MPa	4.2/1.5	4.2/1.5
Refrigerant piping	Liquid side/ Gas side	mm(inch)	Φ9.52/Φ15.9(3/8"/5/8")	Φ9.52/Φ15.9(3/8"/5/8")
	Max. refrigerant pipe length	m	50	50
	Max. difference in level	m	30	30
Ambient temperature	Cooling	°C	-15~50	-15~50
	Heating	°C	-15~24	-15~24
Qty'per 20' /40' /40'HQ		Outdoor unit	44/96/138	22/48/48

Notes:

1) Capacities are based on the following conditions:

Cooling(T1): - Indoor Temperature 27°C(80.6°F) DB /19 °C(66.2°F) WB Heating: - Indoor Temperature 20°C(68°F) DB / 15°C(59°F) WB
 -Outdoor Temperature 35 °C(95°F) DB /24 °C(75.2°F) WB -Outdoor Temperature 7°C(44.6°F) DB / 6°C(42.8°F) WB
 -Interconnecting Piping Length 5m - Interconnecting Piping Length 5 m
 - Level Difference of Zero. - Level Difference of Zero.

2) Capacities are Net Capacities.

3) Due to our policy of innovation some specifications may be changed without notification.

3. Dimensional Drawings

3.1 Indoor Unit

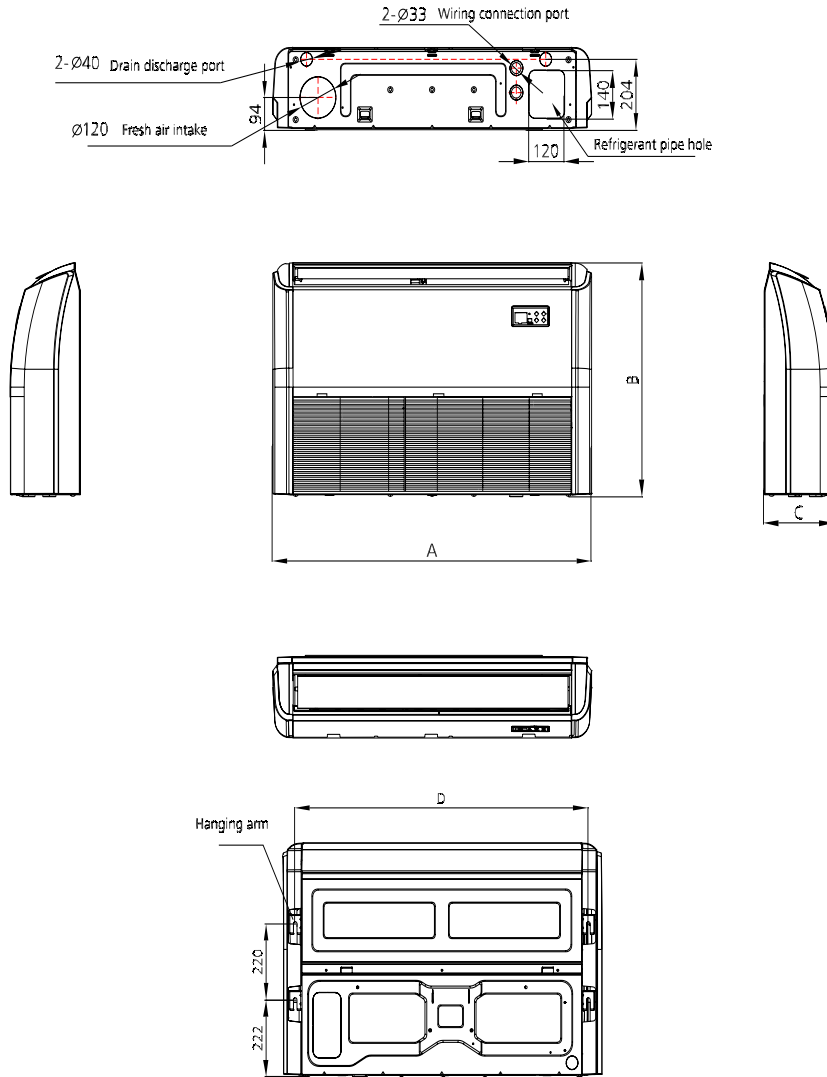

Model (kBtu/h)	Unit	A	B	C	D
24	mm	1068	675	235	983
	inch	42.05	26.57	9.25	38.7
36-60	mm	1650	675	235	1565
	inch	64.96	26.57	9.25	61.61

3.2 Outdoor Unit

MOX430-24HDN1-QW

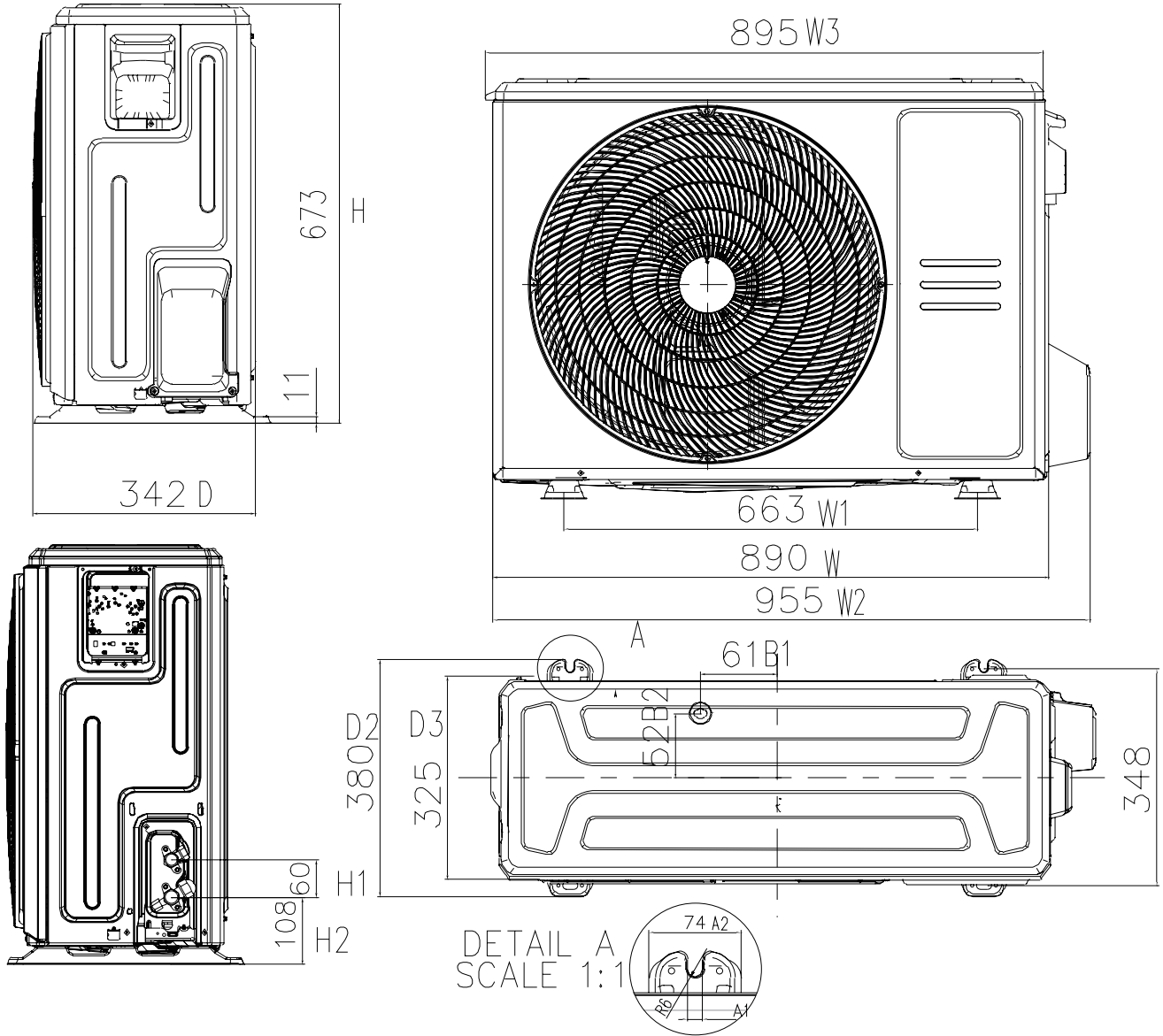

MOD30U-36HDN1-RW(GA), MOD30U-48HDN1-RW(GA)

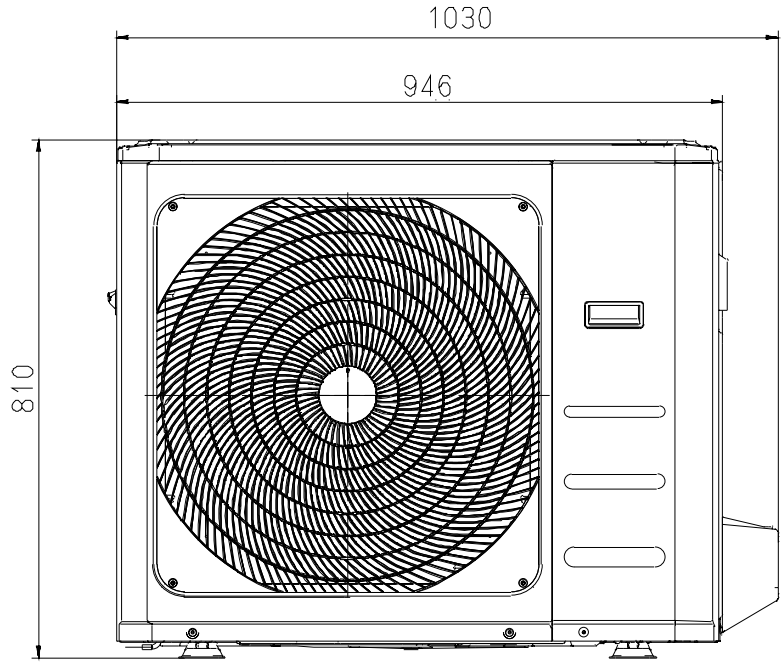
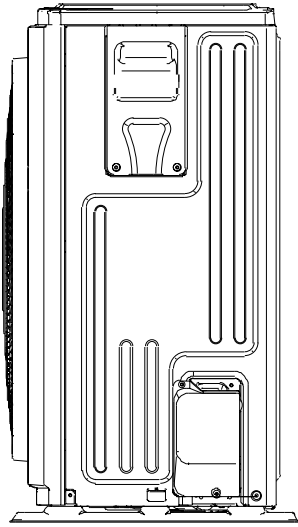

DETAIL A
SCALE 1 : 2

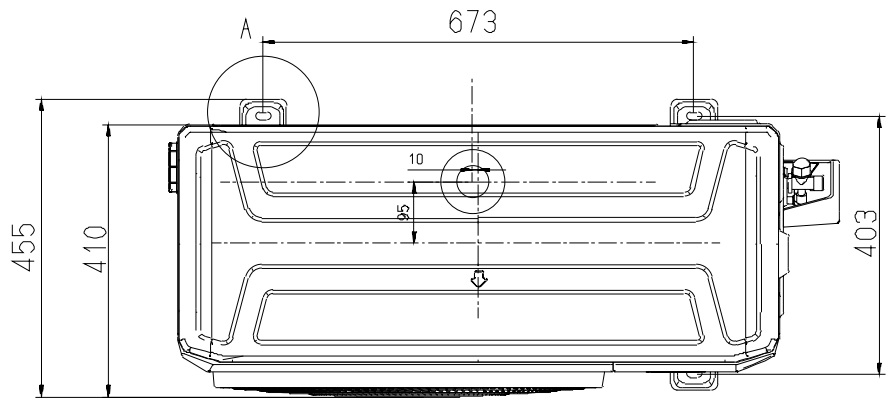
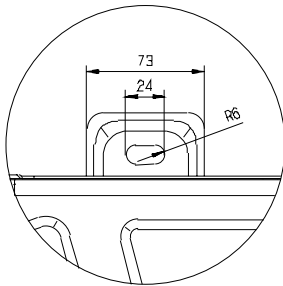

MOE30U-55HDN1-RW(GA)

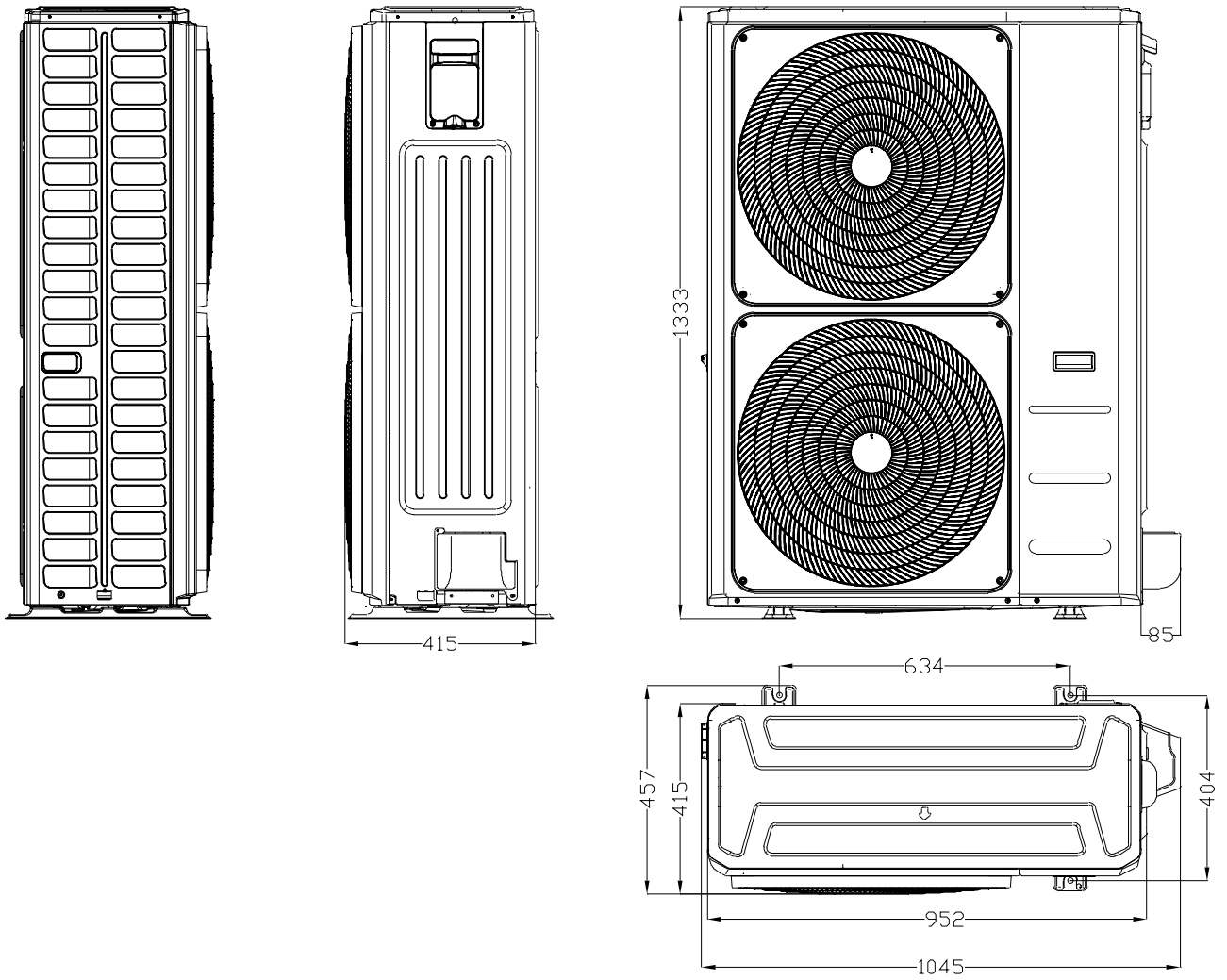

4. Electrical Wiring Diagrams

4.1 Indoor unit

Abbreviation	Paraphrase
Y/G	Yellow-Green Conductor
CAP1	Indoor Fan Capacitor
FAN	Indoor Fan
PUMP	PUMP
L	LIVE
N	NEUTRAL
TO CCM Comm.Bus	Central Controller
T1	Indoor Room Temperature
T2	Coil Temperature of Indoor Heat Exchanger
P1	Super High Speed
P2	High Speed

MUE-24HRFNX-QRD0W(GA), MUE-36HRFNX-QRD0W(GA), MUE-48HRDN1-QW(GA), MUE-55HRDN1-QW(GA)

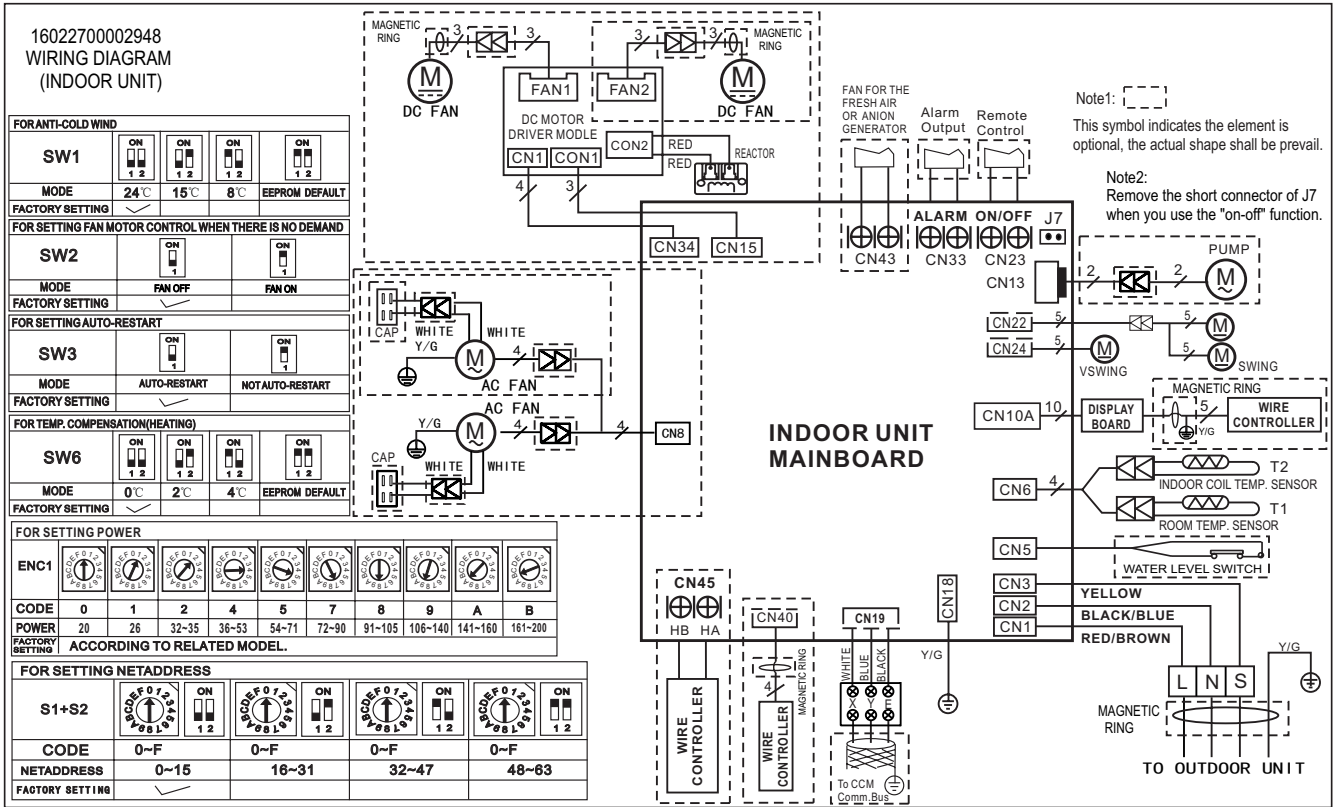

Specifications

4.2 Some connectors introduce:

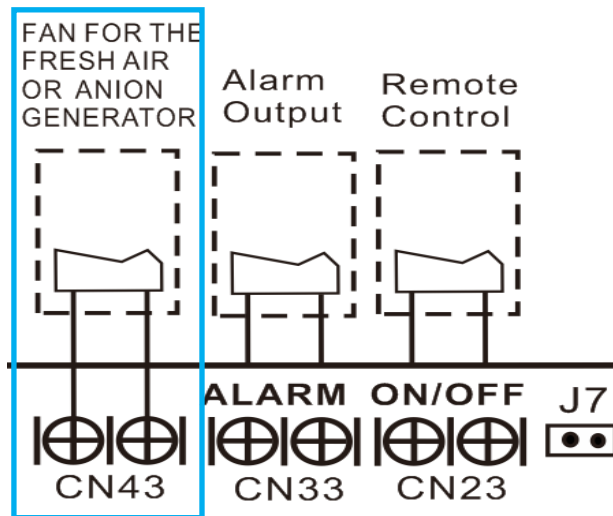

A. For new fresh motor terminal port (also for Anion generator) CN43:

1. Connect the fan motor to the port , no need care L/N of the motor;
2. The output voltage is the power supply;
3. The fresh motor can not exceed 200W or 1A , follow the smaller one;
4. The new fresh motor will be worked when the indoor fan motor work ;when the indoor fan motor stops , the new fresh motor would be stopped ;
5. When the unit enter force cooling mode or capacity testing mode , the fresh motor isn't work.

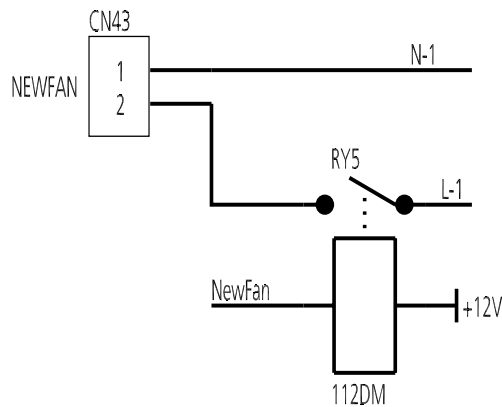

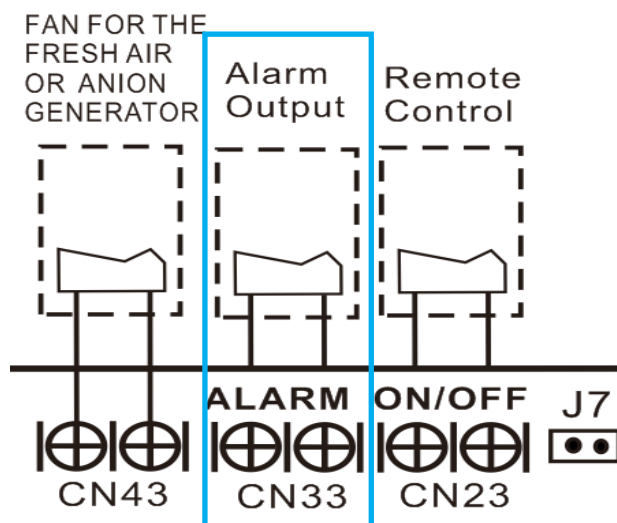

B For ALARM terminal port CN33

1. Provide the terminal port to connect ALARM ,but no voltage of the terminal port , the power from the ALARM system (not from the unit)
2. Although design voltage can support higher voltage ,but we strongly ask you connect the power less than 24V, current less than 0.5A
3. When the unit occurs the problem , the relay would be closed , then ALARM works

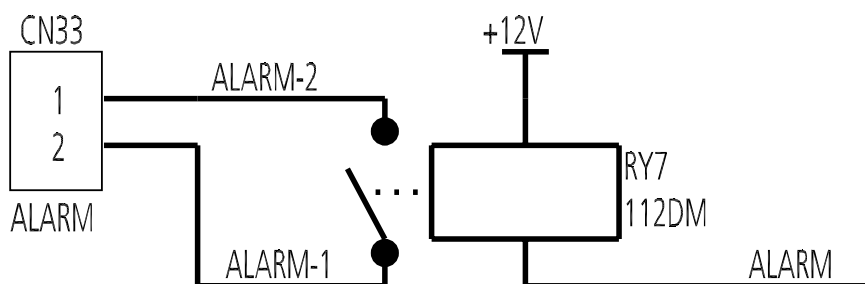

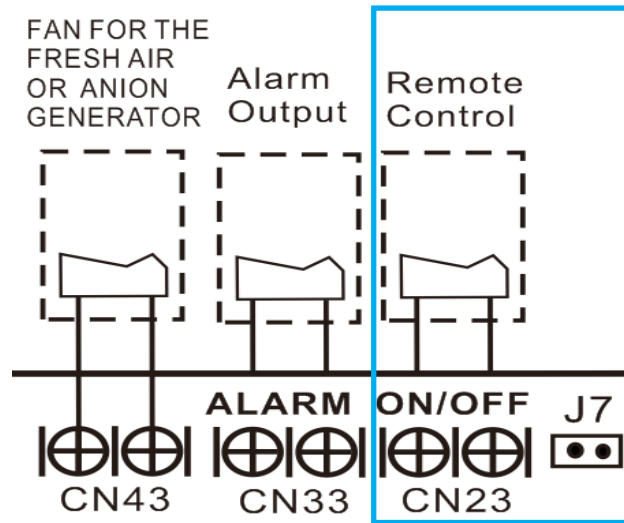

C. For remote control (ON-OFF) terminal port CN23 and short connector of J7

1. Remove the short connector of J7 when you use ON-OFF function;
2. When remote switch off (OPEN) ;the unit would be off;
3. When remote switch on (CLOSE) ;the unit would be on;
4. When close/open the remote switch, the unit would be responded the demand within 2 seconds;
5. When the remote switch on . you can use remote controller/ wire controller to select the mode what you want ;when the remote switch off , the unit would not respond the demand from remote controller/wire controller.

when the remote switch off , but the remote controller / wire controller are on, CP code would be shown on the display board.

6.The voltage of the port is 12V DC , design Max.current is 5mA.

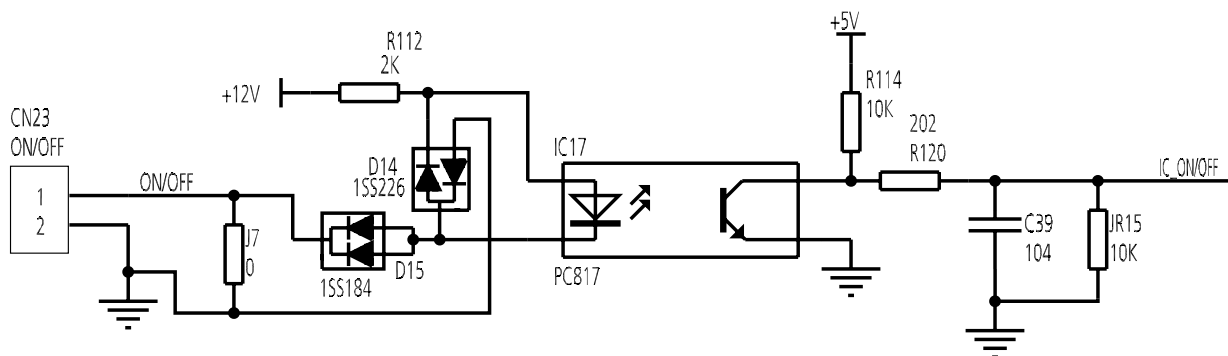



4.3 Micro-Switch Introduce:



FOR ANTI-COLD WIND				
SW1				
TELO	24°C	15°C	8°C	EEPROM DEFAULT
FACTORY SETTING	✓			

A. Micro-switch SW1 is for selection of indoor fan stop temperature (TELO) when it is in anti-cold wind action in heating mode.

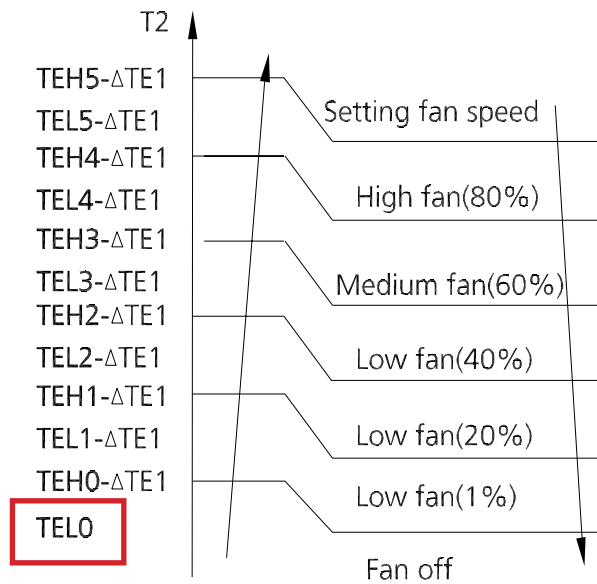
Range: 24°C, 15°C, 8°C, according to EEROM setting (reserved for special customizing).

FOR SETTING FAN MOTOR CONTROL WHEN THERE IS NO DEMAND		
SW2		
MODE	FAN OFF	FAN ON
FACTORY SETTING	✓	

B. Micro-switch SW2 is for selection of indoor FAN ACTION if room temperature reaches the set point and the compressor stops.

Range: OFF (in 127s), Keep running.



FOR SETTING AUTO-RESTART		
SW3		
MODE	AUTO-RESTART	NOT AUTO-RESTART
FACTORY SETTING	✓	

C. Micro-switch SW3 is for selection of auto-restart function.

Range: Active, inactive



FOR TEMP. COMPENSATION(HEATING)				
SW6				
CODE	0°C	2°C	4°C	EEPROM default
FACTORY SETTING	✓			

D. Micro-switch SW6 is for selection of temperature compensation in heating mode. This helps to reduce the real temperature difference between ceiling and floor so that the unit could run properly. If the height of installation is lower, smaller value could be chosen.

Range: 6°C, 4°C, 2°C, E function (reserved for special customizing)

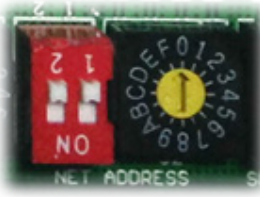

FOR SETTING NETADDRESS				
S1+S2				
CODE	0~F		0~F	
NETADDRESS	0~15		16~31	
FACTORY SETTING	✓			

E. Micro-switch S1 and dial-switch S2 are for address setting when you want to control this unit by a central controller.

Range: 00-63

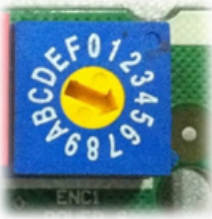

FOR SETTING POWER(DC MOTOR MODEL ONLY)										
ENC1										
CODE	0	1	2	4	5	7	8	9	A	B
POWER	20	26	32-35	36-53	54-71	72-90	91-105	106-140	141-160	161-200
FACTORY SETTING	ACCORDING TO RELATED MODEL.									

F. Dial-switch ENC1: The indoor PCB is universal designed for whole series units from 7K to 68K. This ENC1 setting will tell the main program what size the unit is.

NOTE: Usually there is glue on it because the switch position cannot be changed at random unless you want to use this PCB as a spare part to use in another unit. Then you have to select the right position to match the size of the unit.

“20” means 2kW (7K), “105” means 10.5kW(36K), and so on.

4.4 Outdoor Unit

Abbreviation	Paraphrase
CAP1, CAP2, CAP3,CAP4	Capacitor
FAN1	Outdoor Fan Motor
KM8	Contactora
CT1, CT2	AC Current Detector
COMP	Compressor
L-PRO, K2	Low Pressure Switch/Shorting Stub
K1	High Pressure Switch/Shorting Stub
TRANS	Power Transformer
T4	10KΩ RESISTANCE/Outdoor Ambient Temperature
T3	10KΩ RESISTANCE/Coil Temperature of Condenser
XT1	2-Way Terminal/4-Way Terminal
XT2	3-Way Terminal
XT4	Terminal
K3	Compressor Discharge Temperature/Shorting Stub
XP1~XP5,XT5~XT7	Connectors

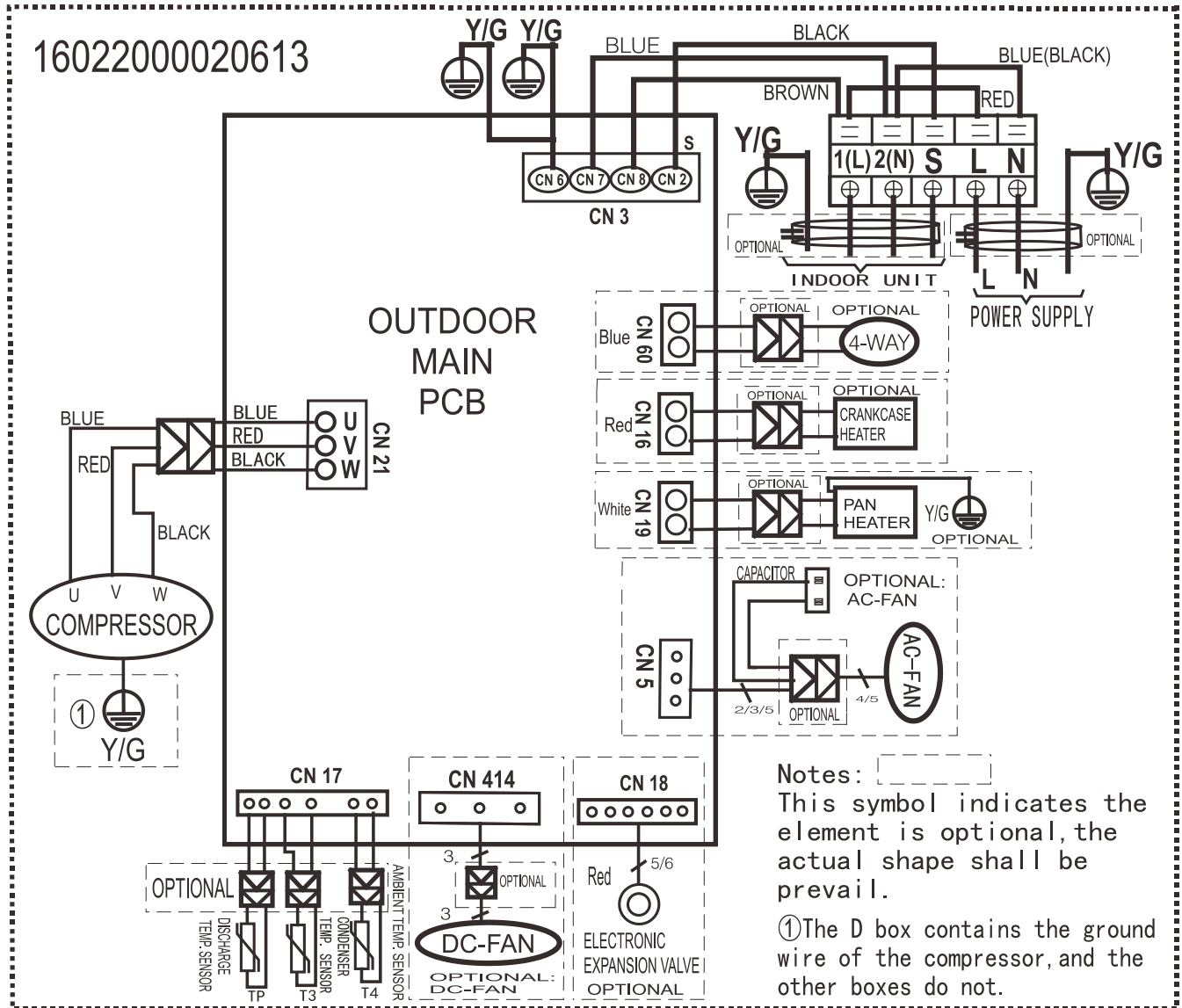

MOD30U-36HDN1-RW(GA), MOD30U-48HDN1-RW(GA), MOE30U-55HDN1-RW(GA)

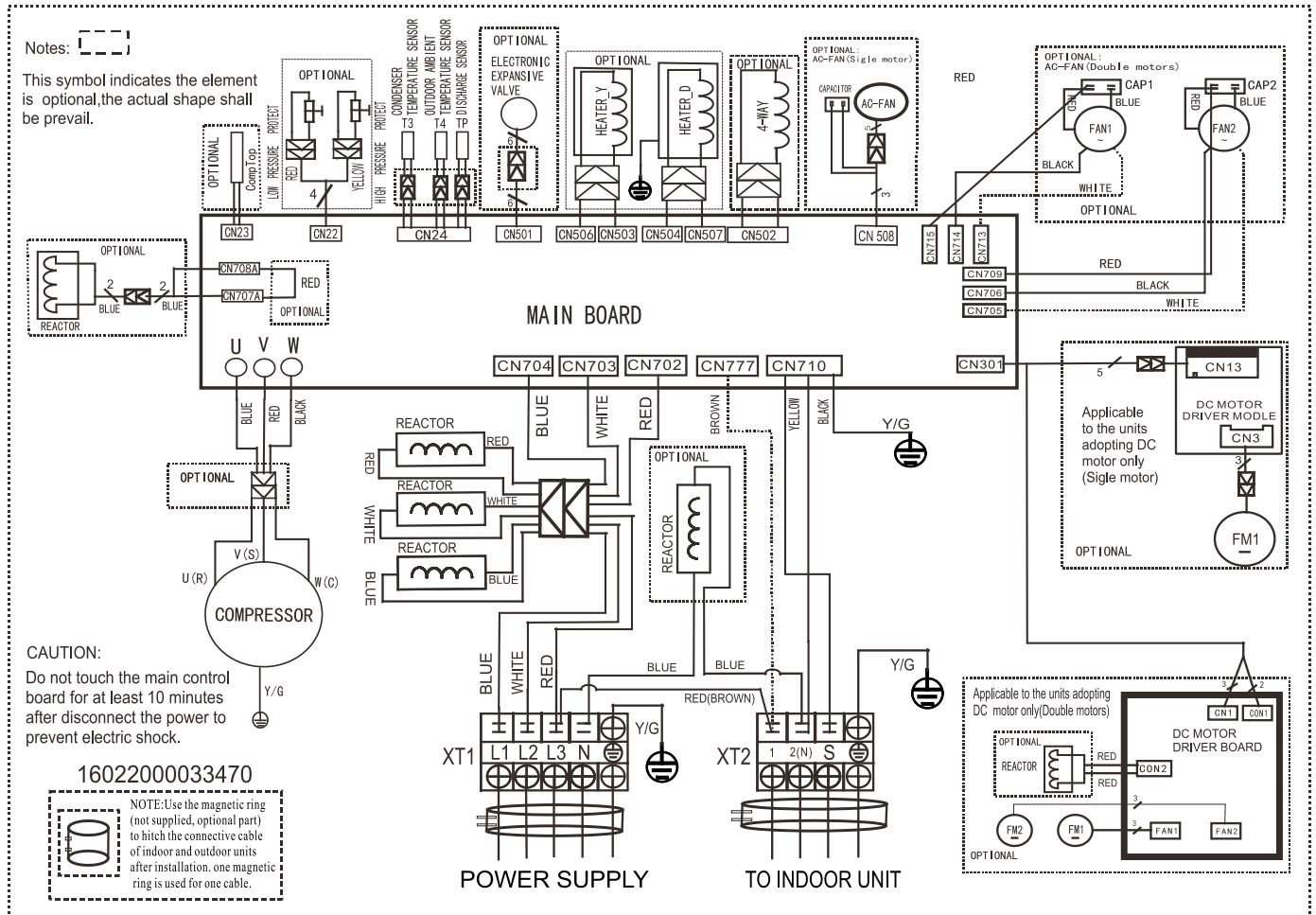

5. Refrigerant Cycle Diagrams

5.1 Heat pump

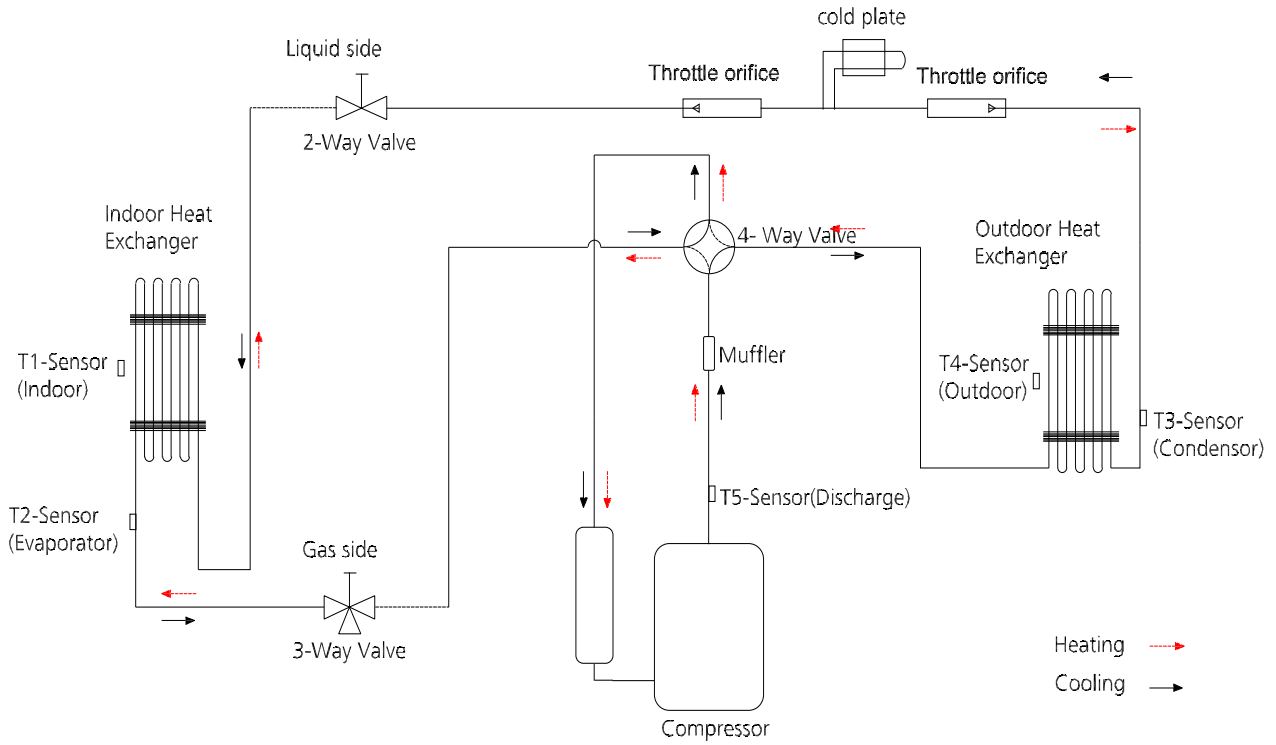

Model	Pipe Size (Diameter:ø) mm(inch)		Piping length (m/ft)		Elevation (m/ft)		Additional Refrigerant
	Gas	Liquid	Rated	Max.	Rated	Max.	
24k	15.9(5/8)	9.52(3/8)	5/16.4	25/82	0	15/49.2	30g/m (0.32oz/ft)

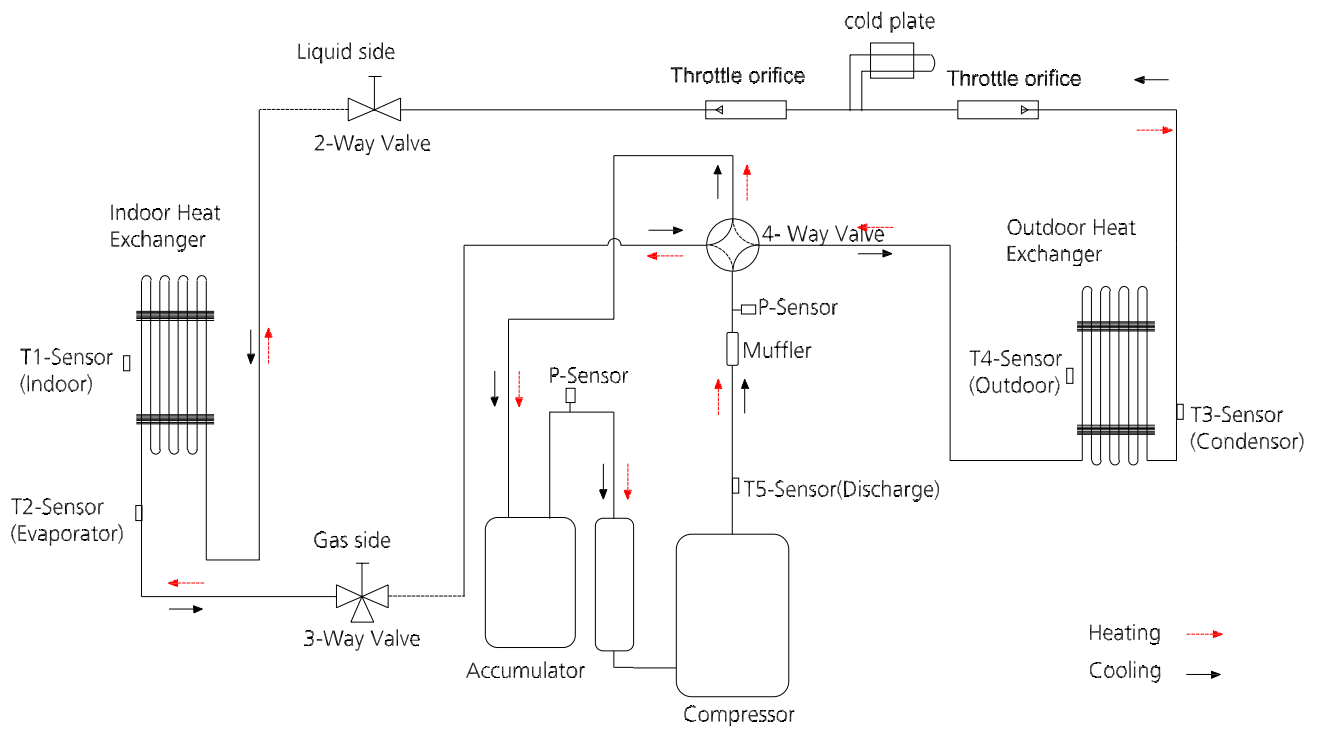

Model	Pipe Size (Diameter:ø) mm(inch)		Piping length (m/ft)		Elevation (m/ft)		Additional Refrigerant
	Gas	Liquid	Rated	Max.	Rated	Max.	
36k	15.9(5/8)	9.52(3/8)	5/16.4	30/98.4	0	20/65.6	30g/m (0.32oz/ft)
48k	15.9(5/8)	9.52(3/8)		50/164	0	30/98.4	
55k	15.9(5/8)	9.52(3/8)					

6. Air Velocity and Temperature Distributions

24K-Ceiling installation:

Discharge Angle 30°

Cooling airflow velocity distributions

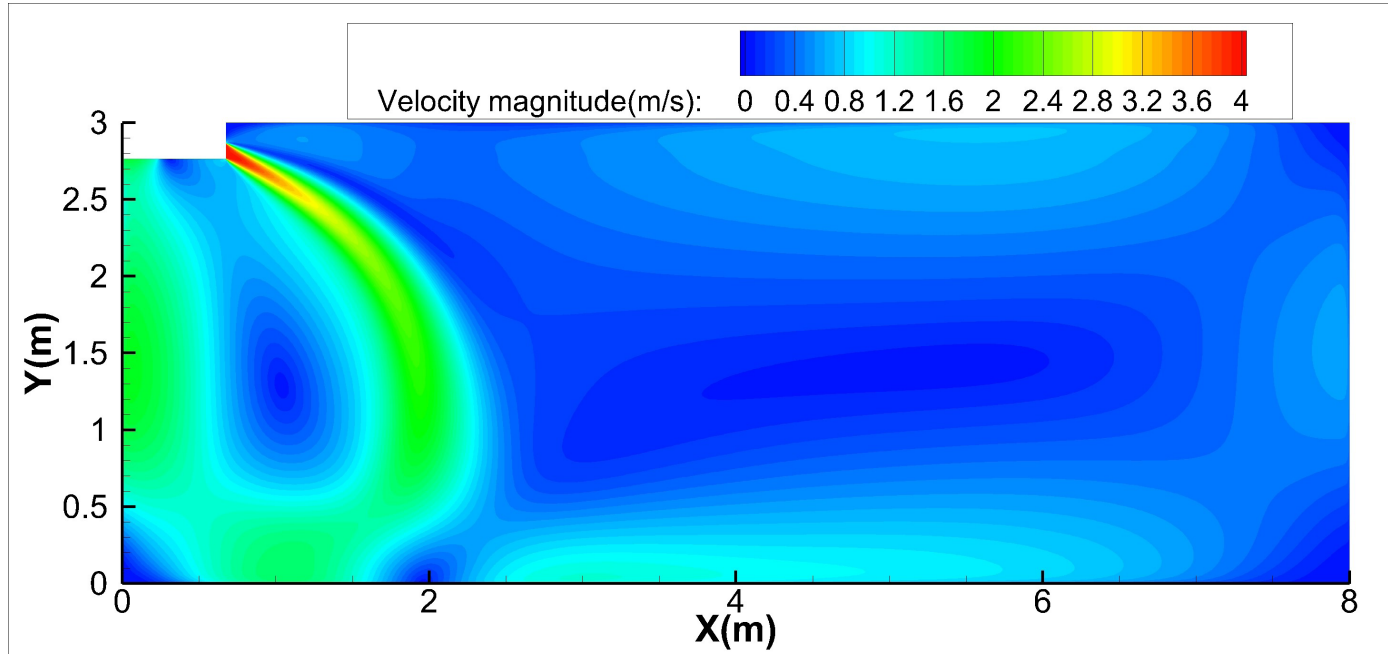

Cooling temperature distributions

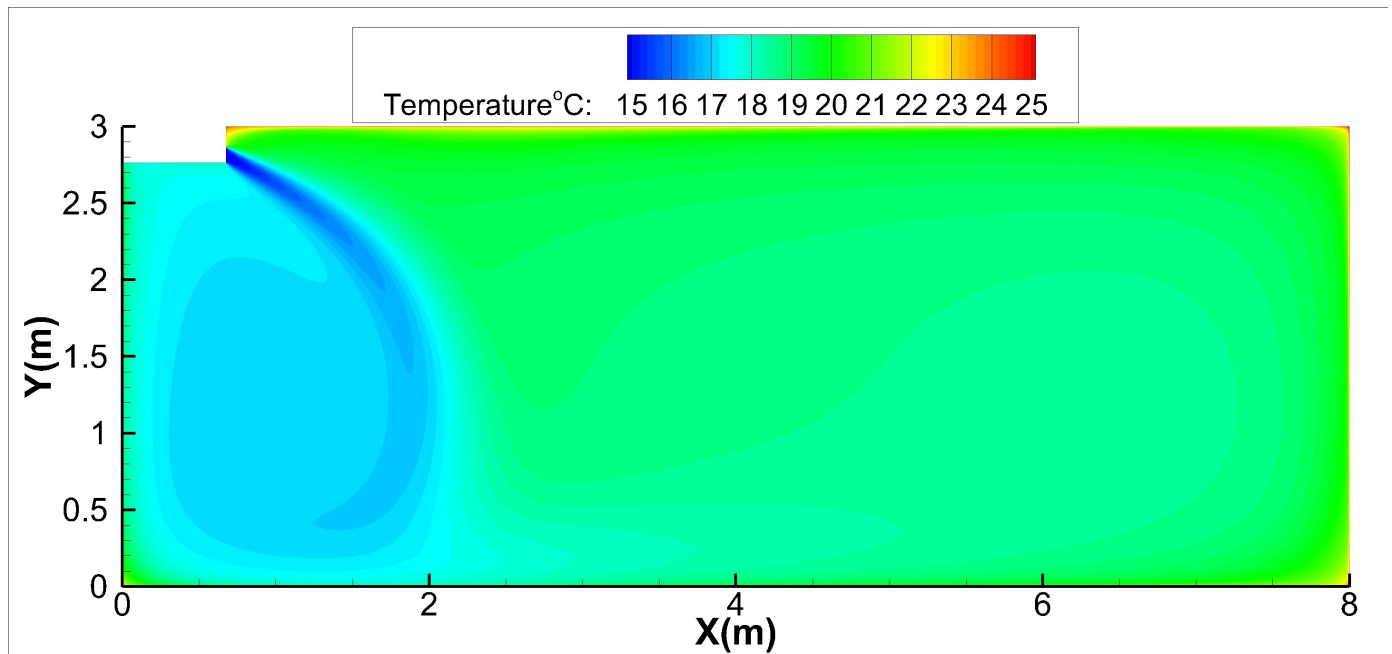

24K-Ceiling installation:

Discharge Angle 60°

Cooling airflow velocity distributions

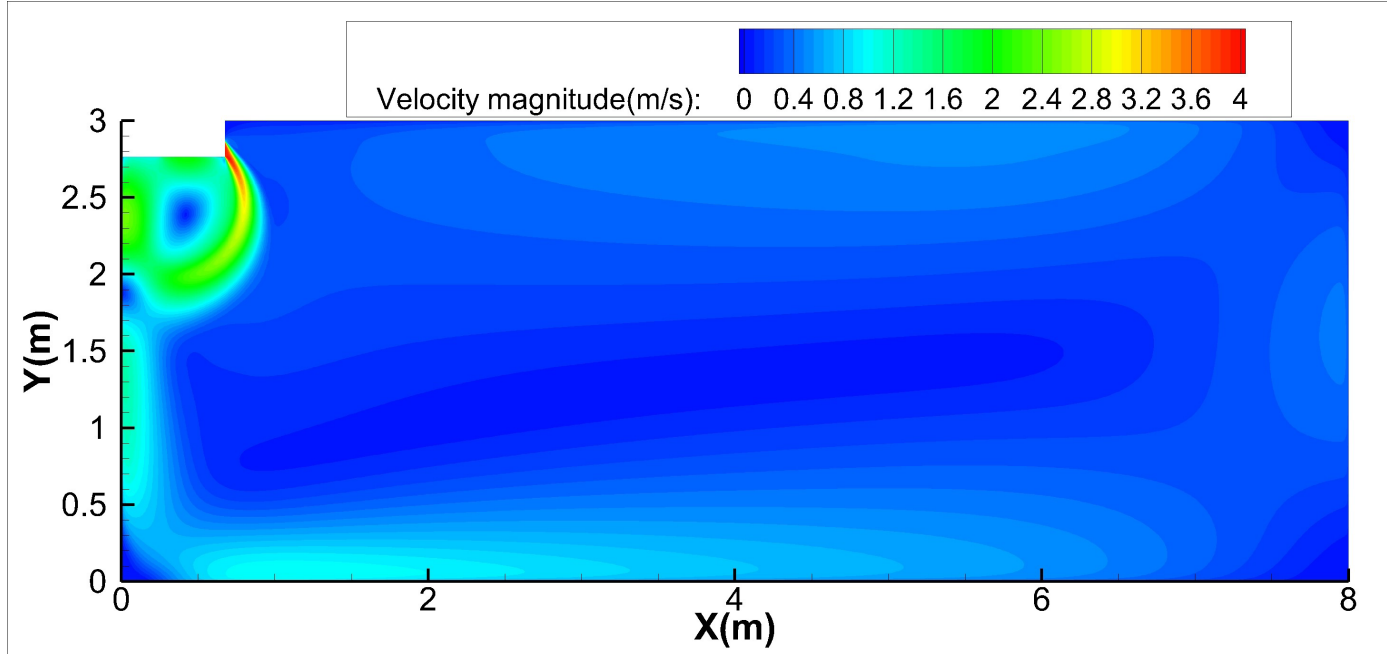

Specifications

Cooling temperature distributions

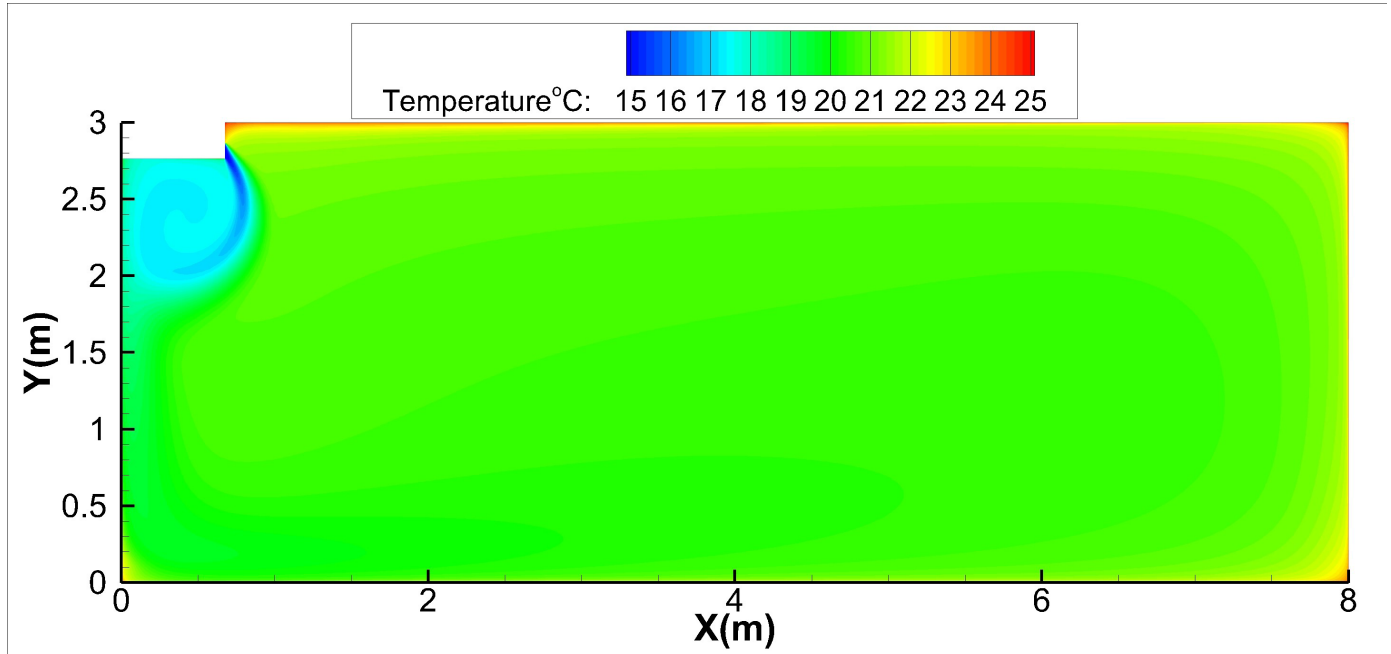

24K-Ceiling installation:

Discharge Angle 30°

Heating airflow velocity distributions

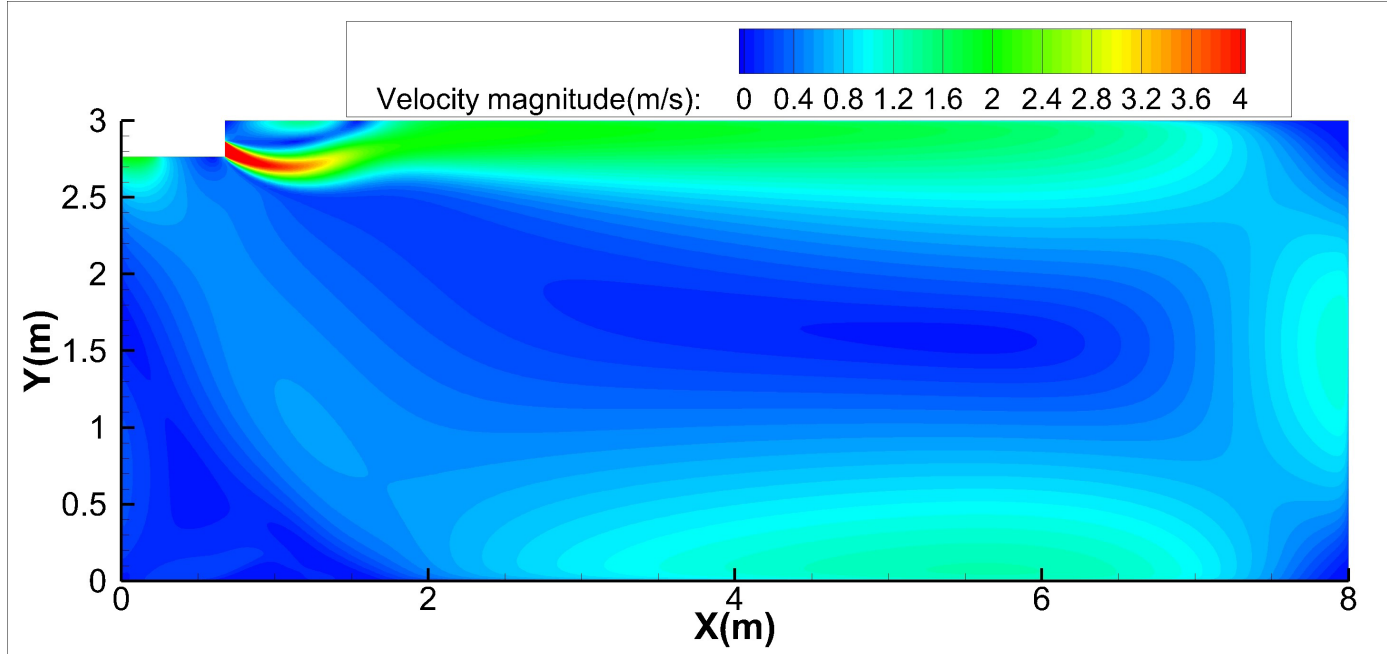

Heating temperature distributions

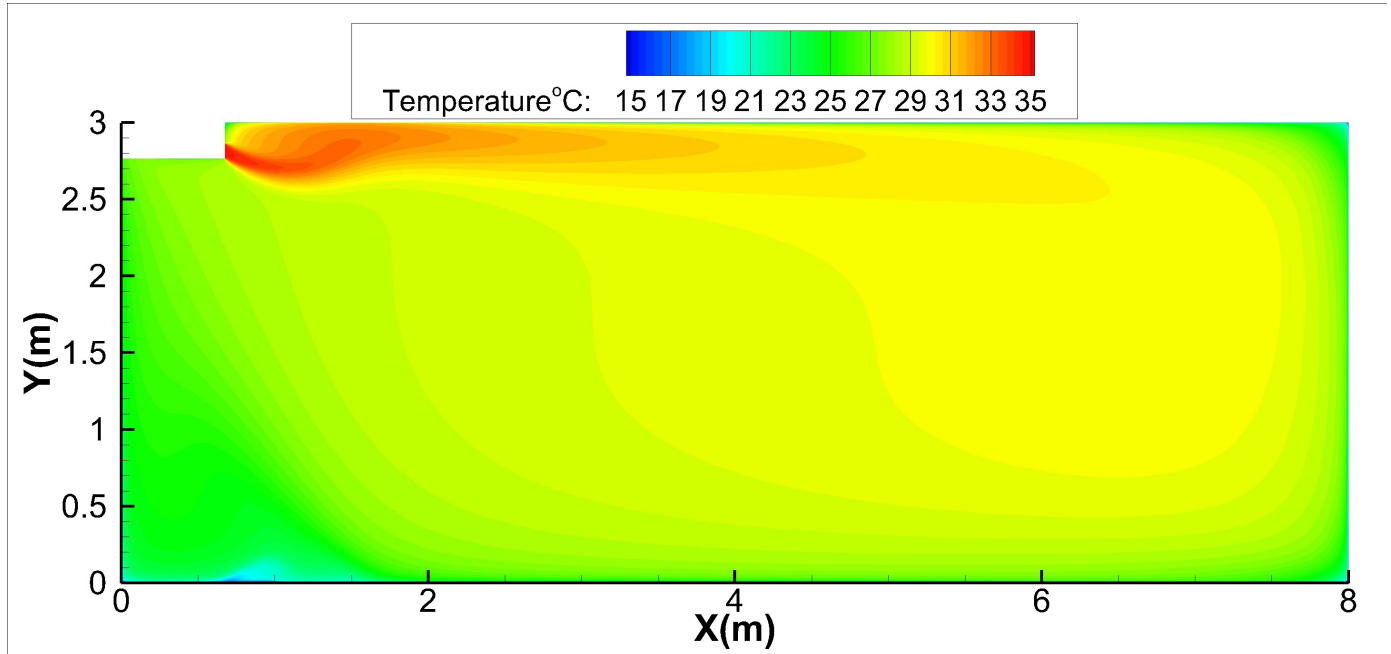

24K-Ceiling installation:

Discharge Angle 60°

Heating airflow velocity distributions

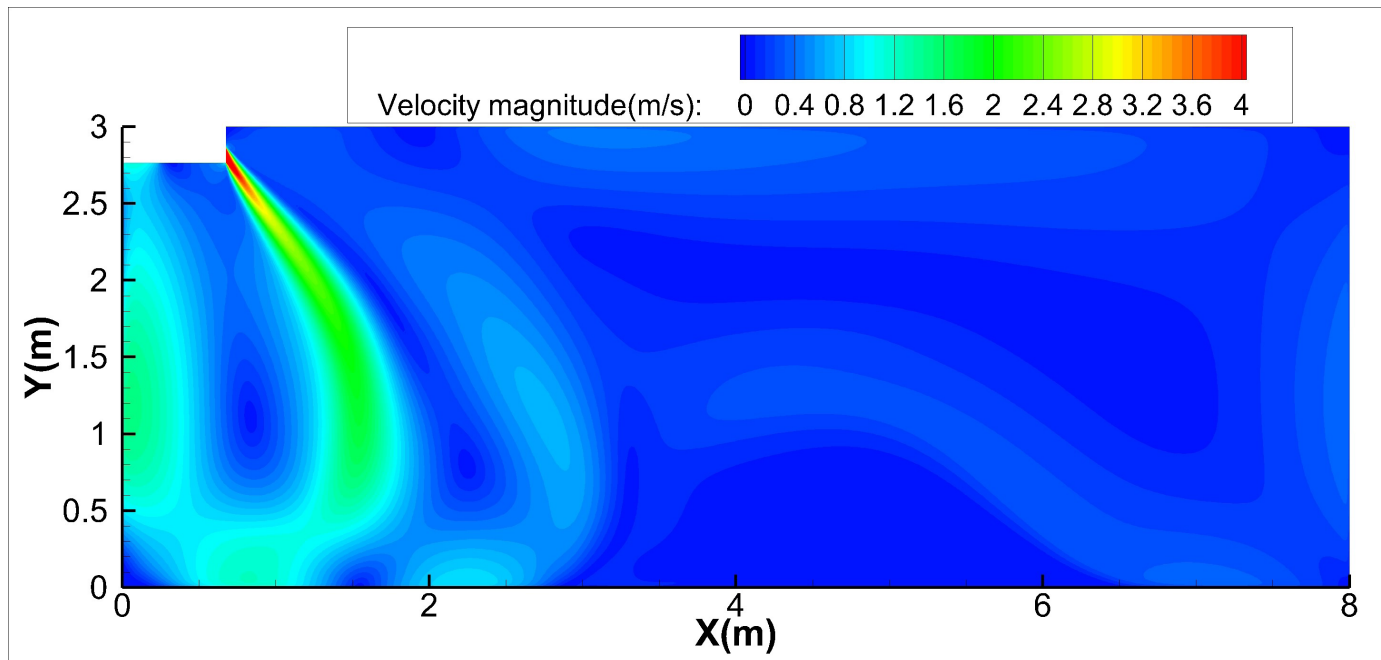

Specifications

Heating temperature distributions

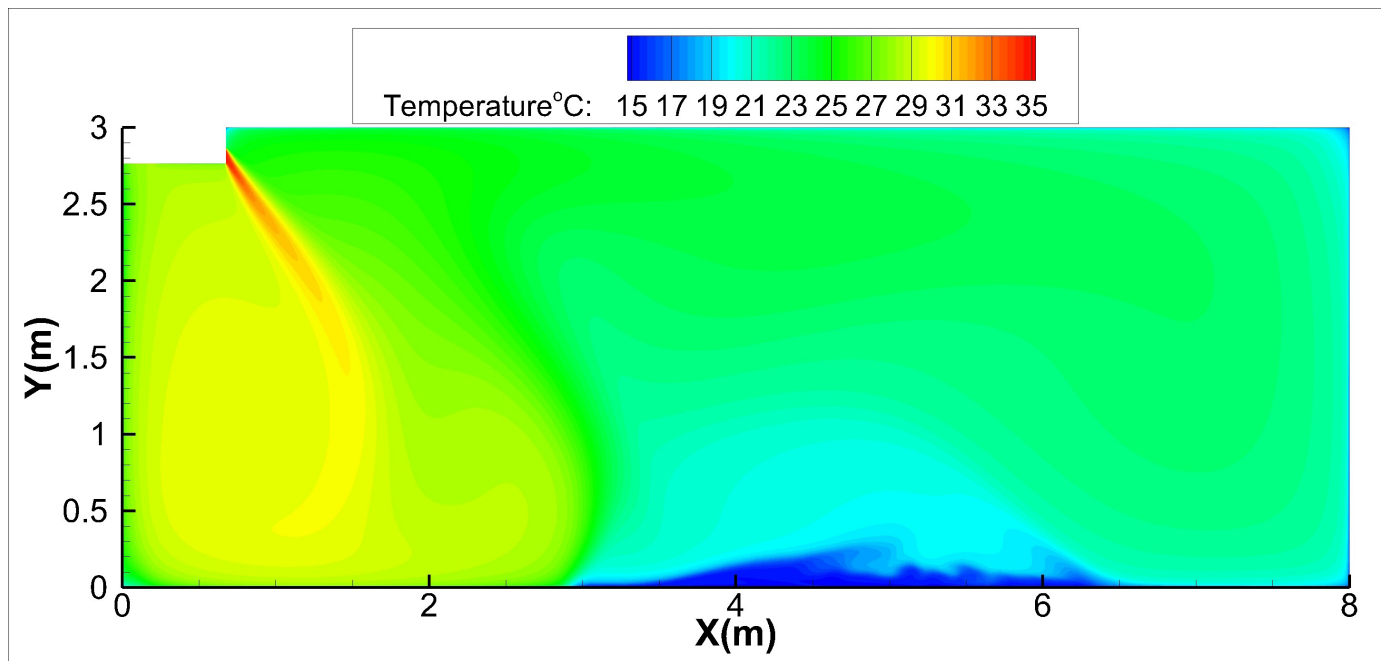

24K-Floor installation:

Discharge Angle 30°

Cooling airflow velocity distributions

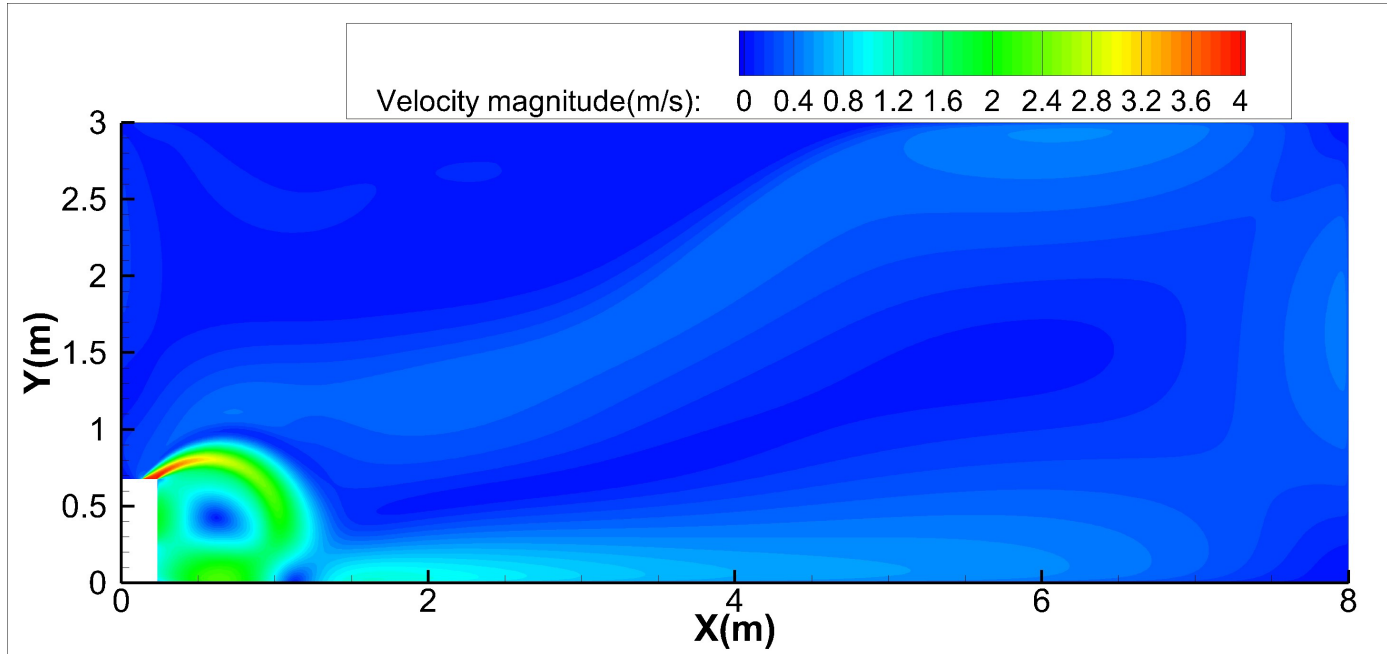

Cooling temperature distributions

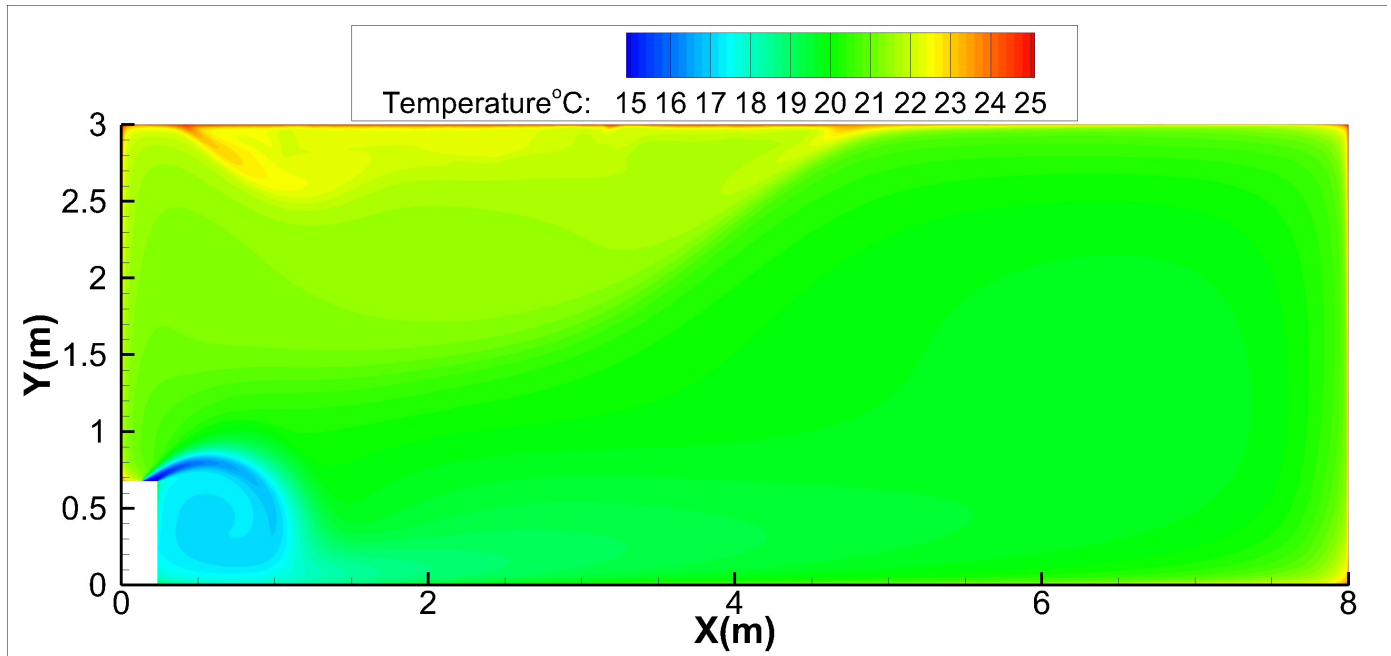

24K-Floor installation:

Discharge Angle 60°

Cooling airflow velocity distributions

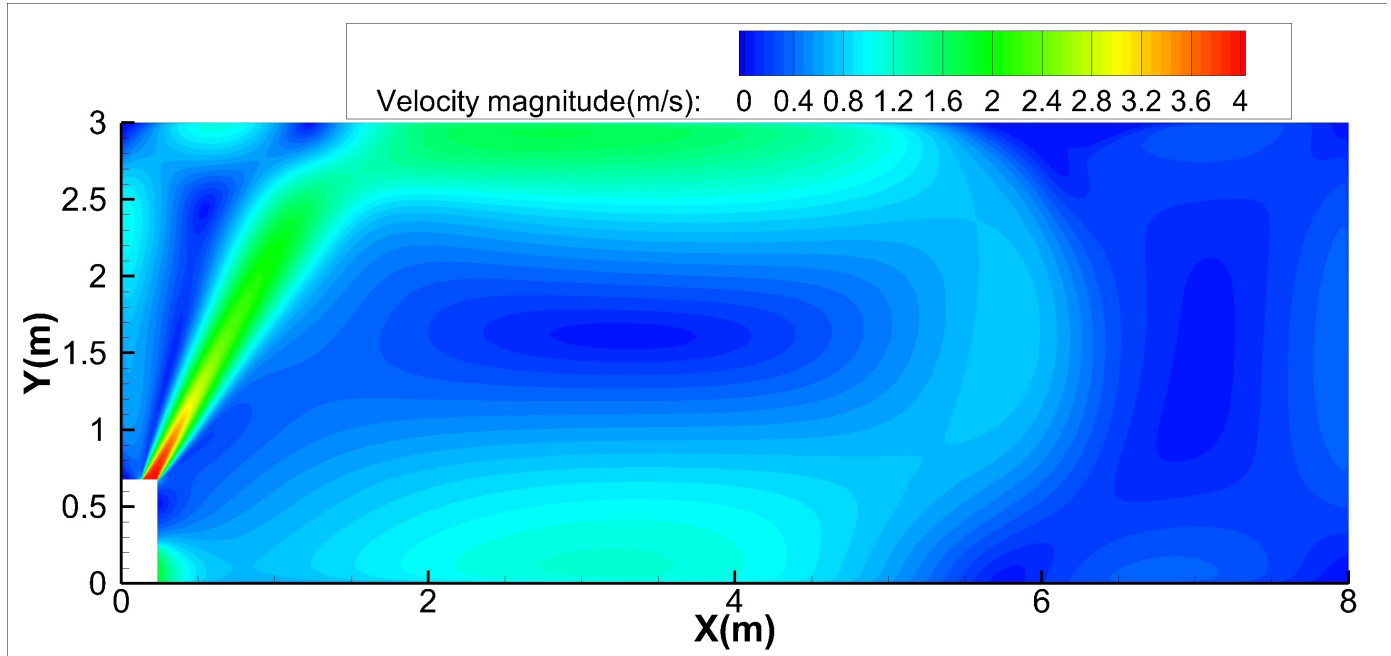

Specifications

Cooling temperature distributions

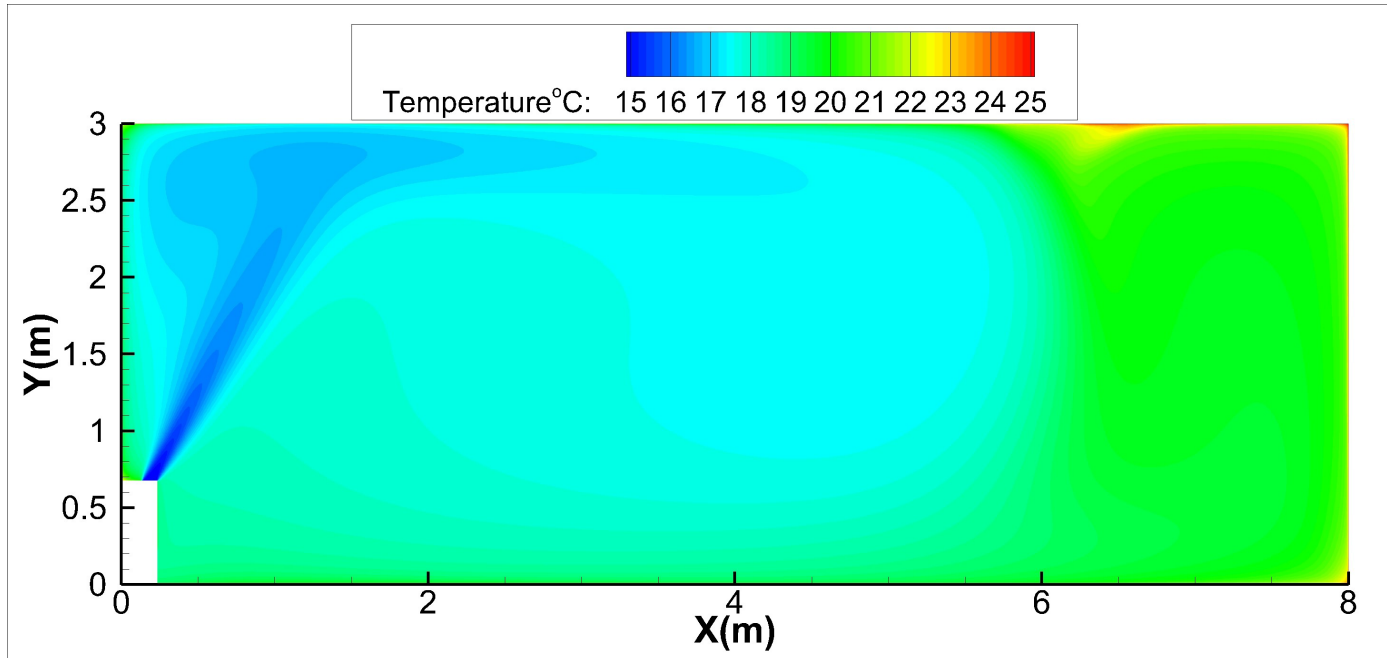

24K-Floor installation:

Discharge Angle 30°

Heating airflow velocity distributions

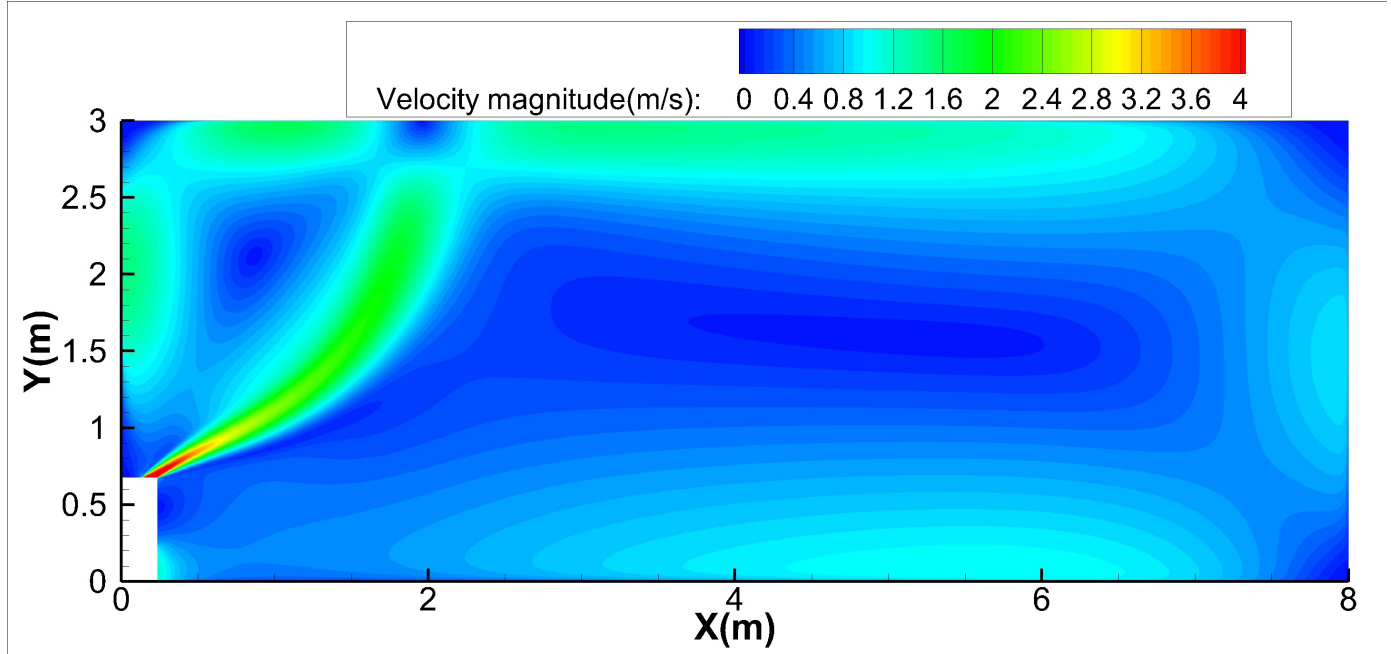

Heating temperature distributions

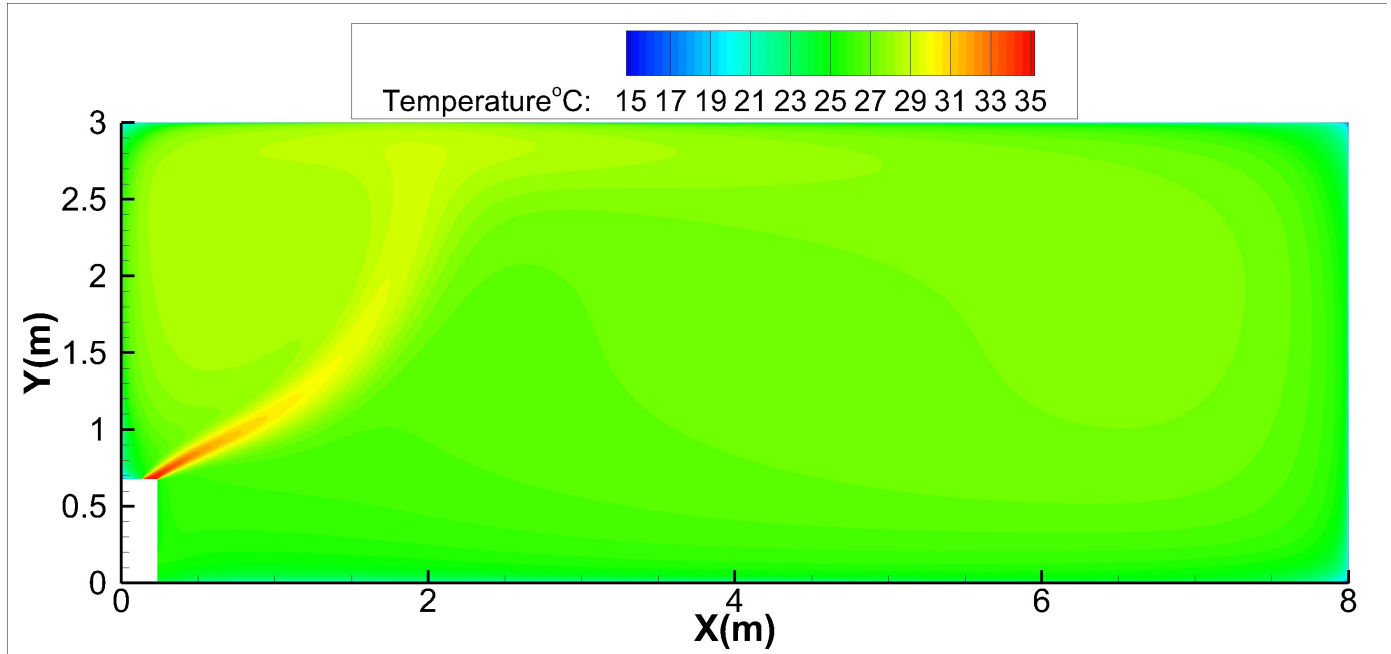

24K-Floor installation:

Discharge Angle 60°

Heating airflow velocity distributions

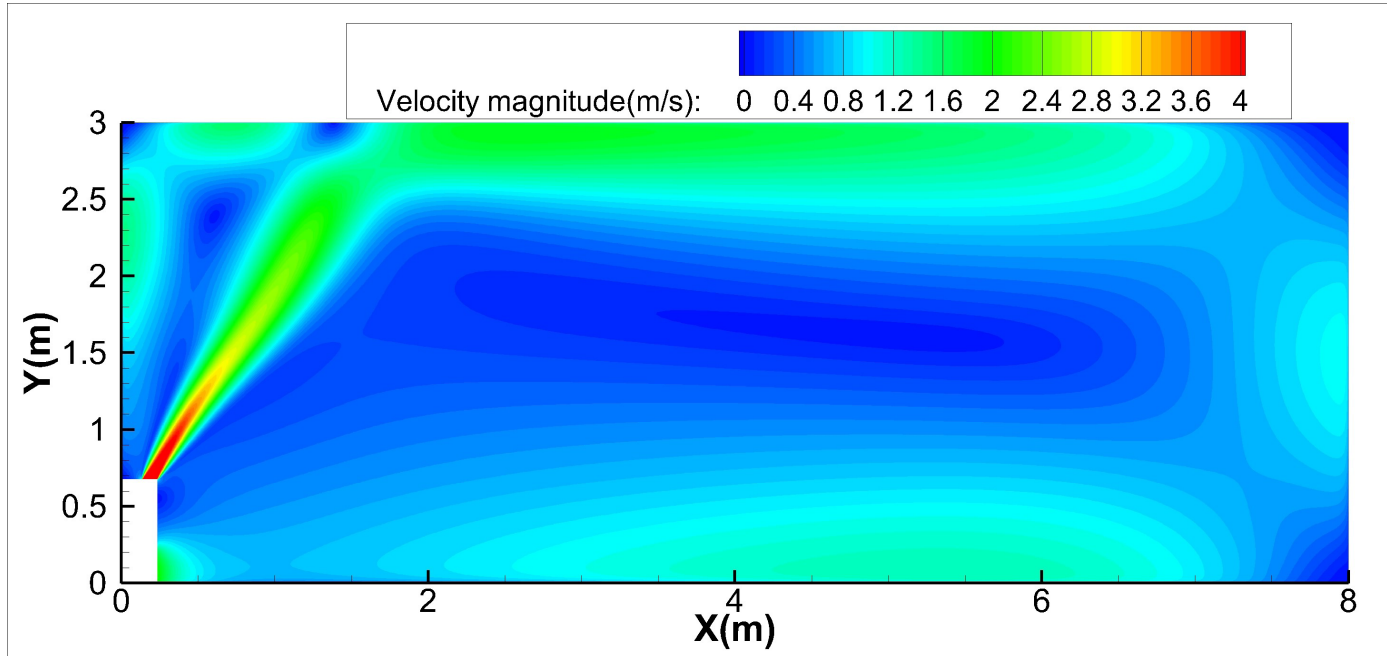

Specifications

Heating temperature distributions

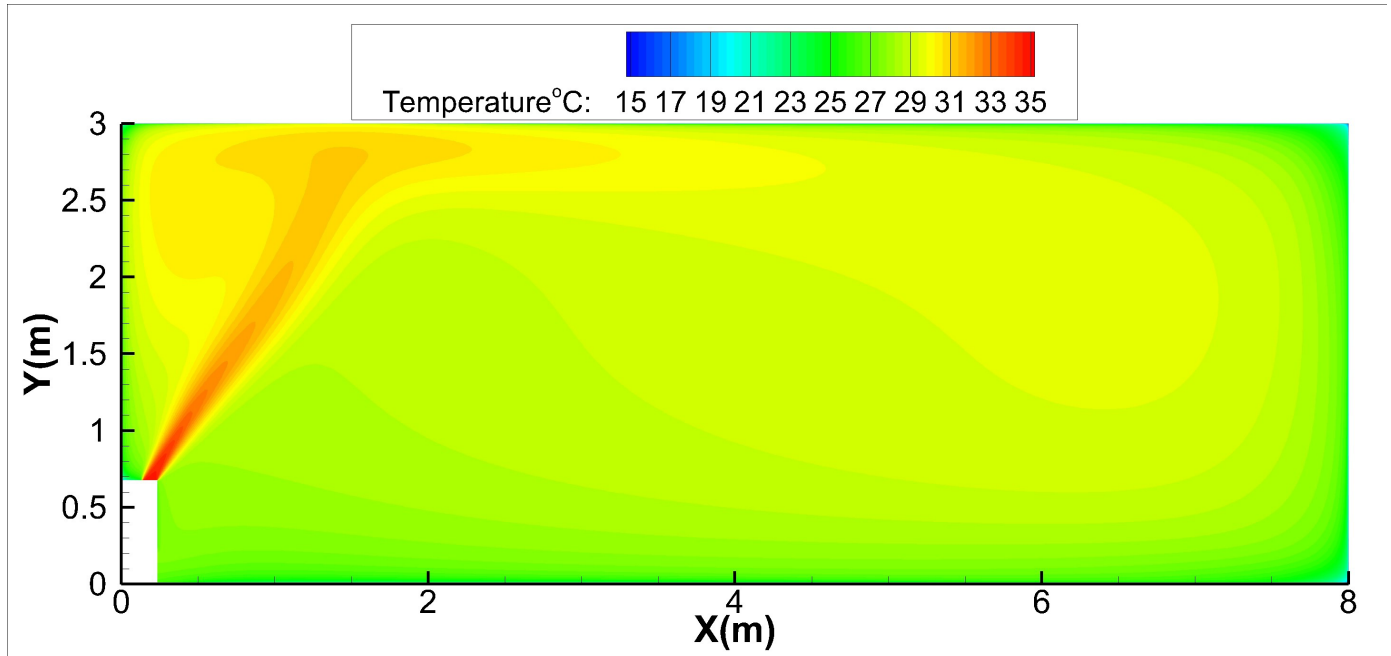

36K-Ceiling installation:

Discharge Angle 30°

Cooling airflow velocity distributions

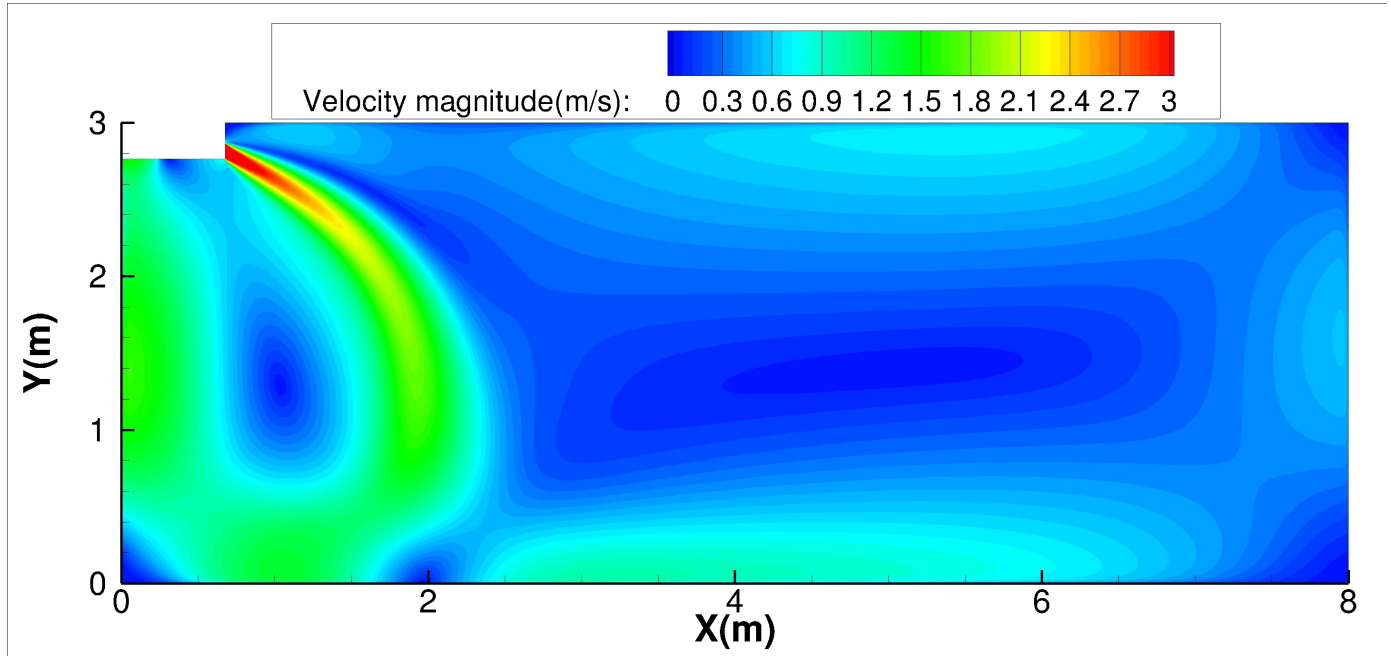

Cooling temperature distributions

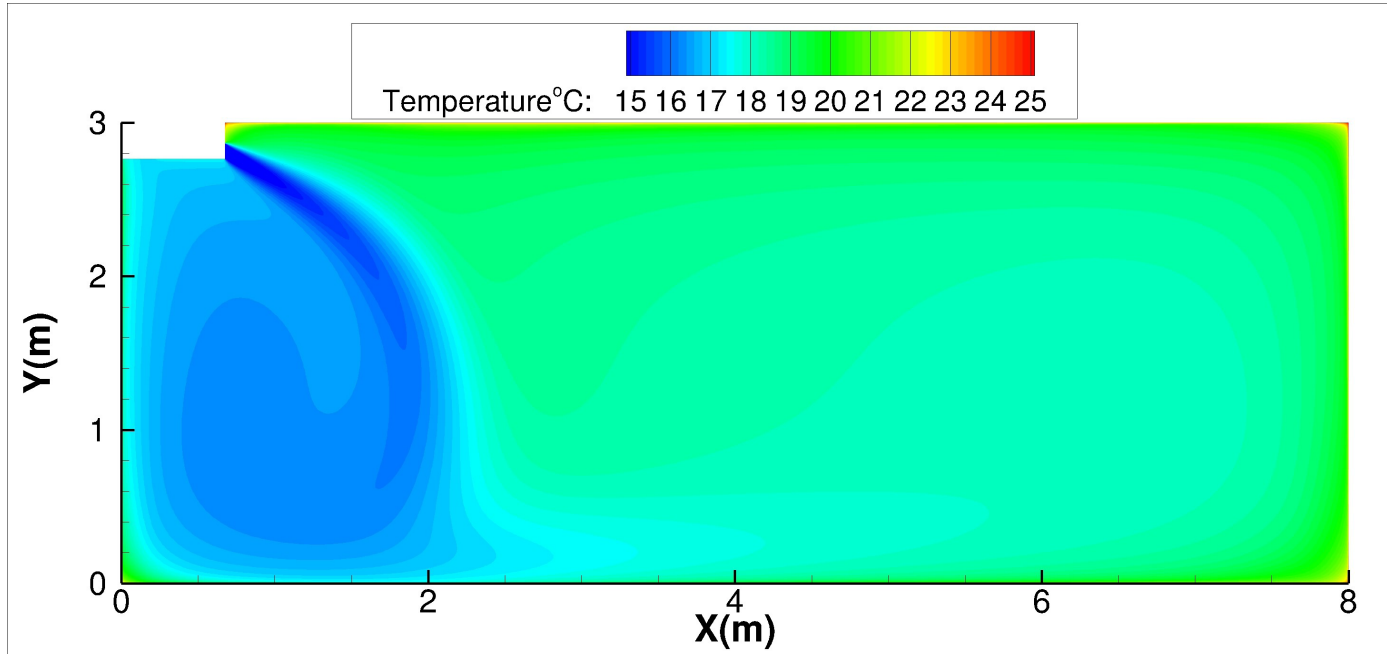

36K-Ceiling installation:

Discharge Angle 60°

Cooling airflow velocity distributions

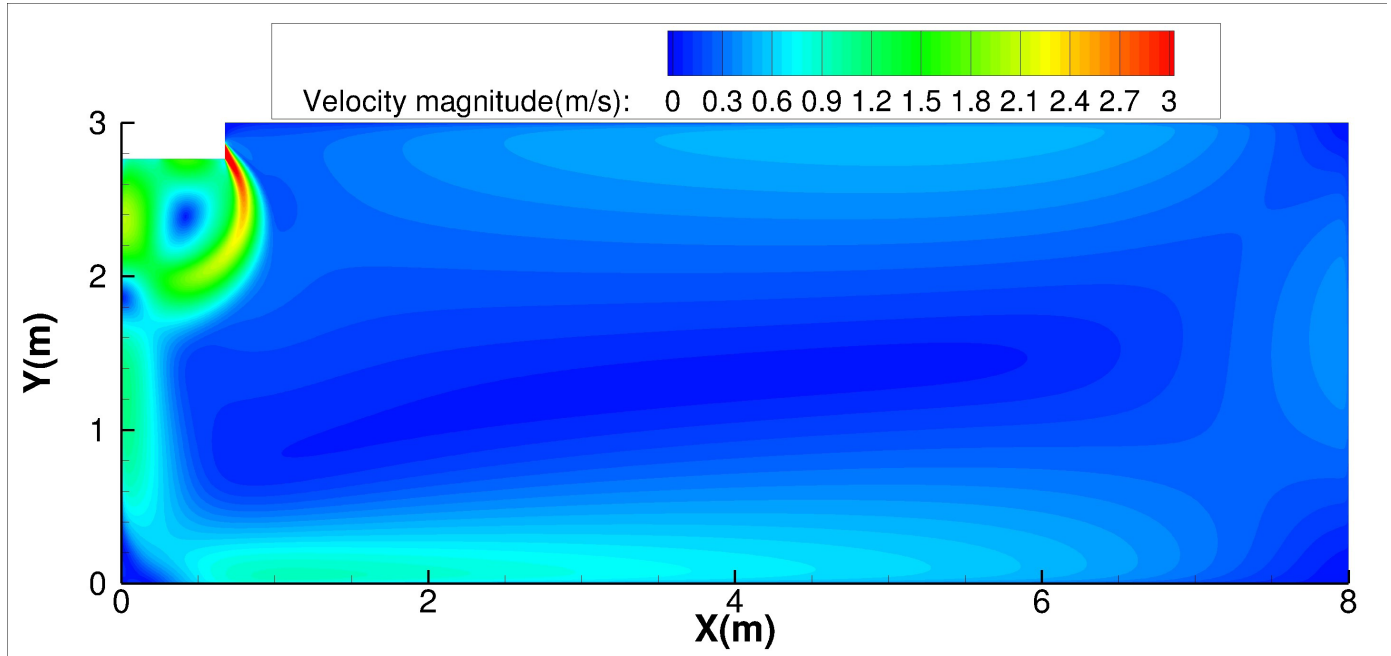

Specifications

Cooling temperature distributions

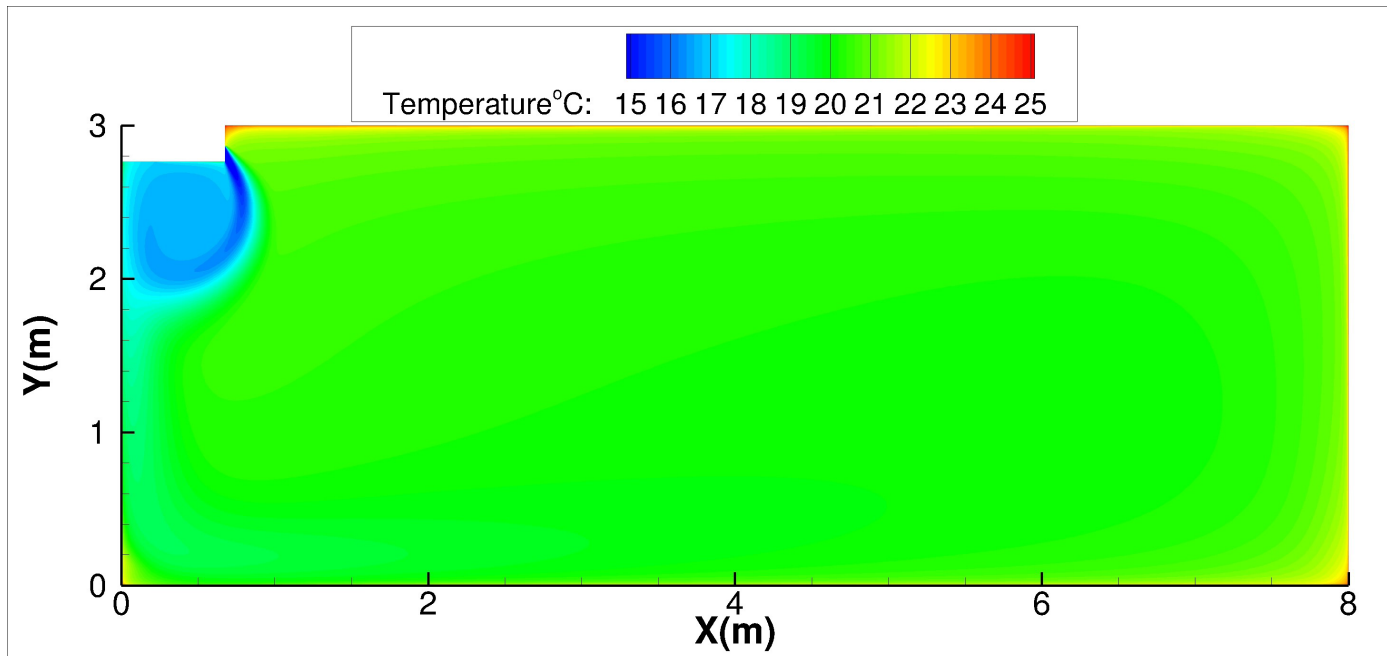

36K-Ceiling installation:

Discharge Angle 30°

Heating airflow velocity distributions

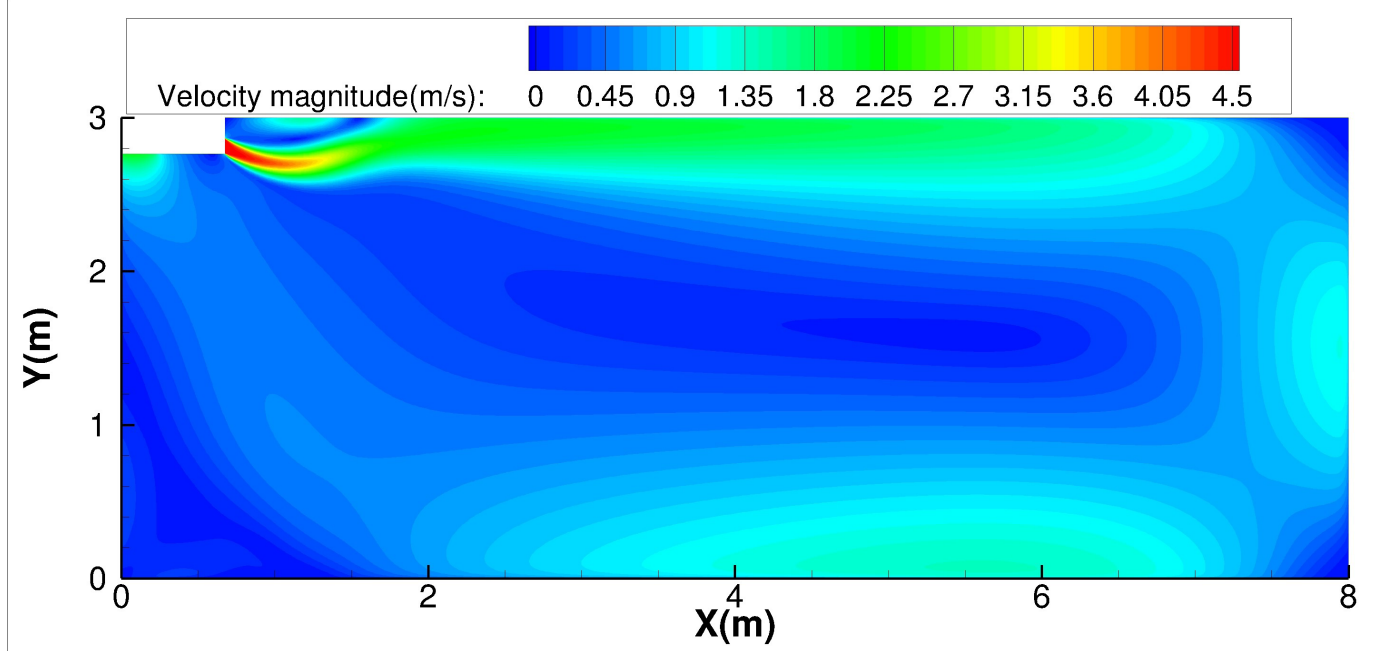

Heating temperature distributions

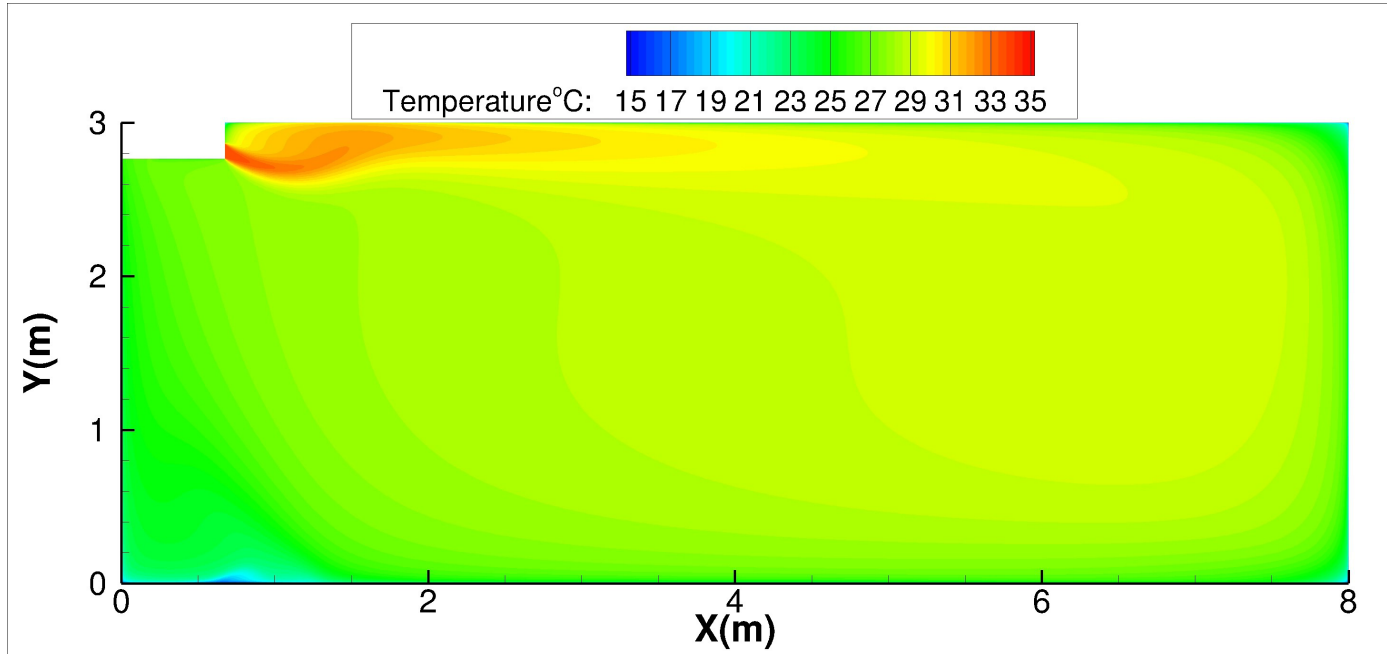

36K-Ceiling installation:

Discharge Angle 60°

Heating airflow velocity distributions

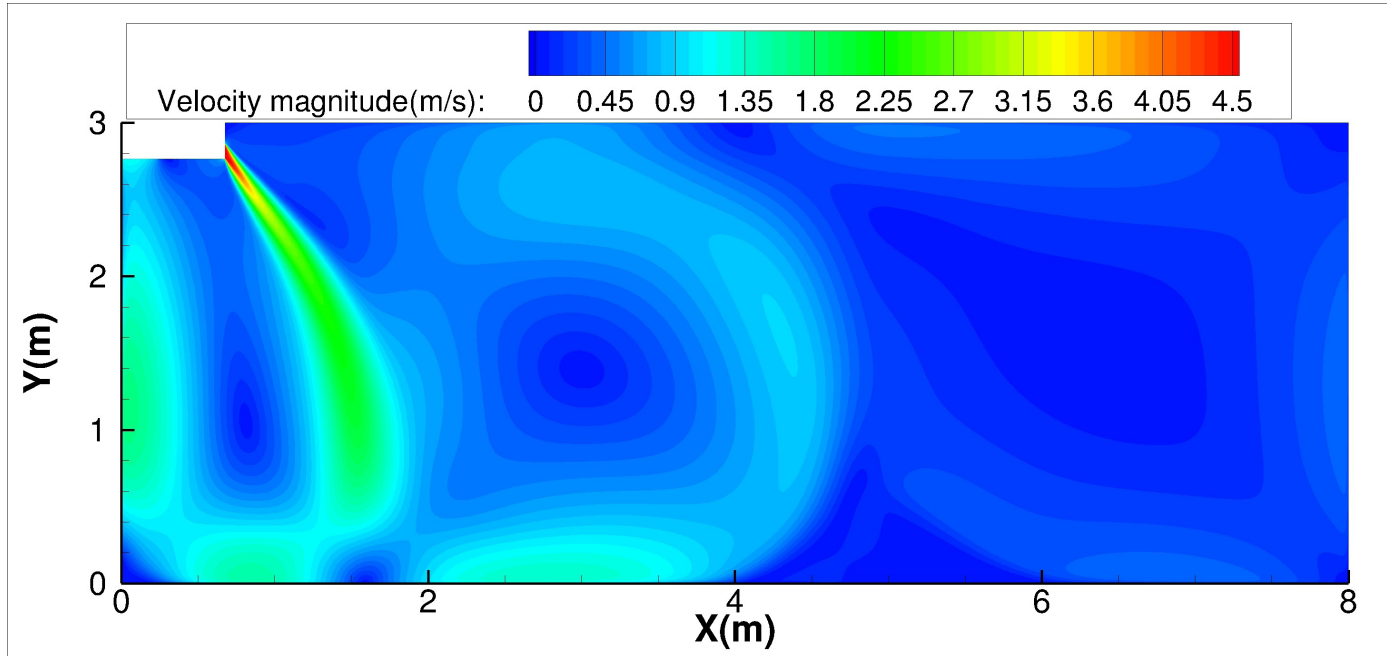

Specifications

Heating temperature distributions

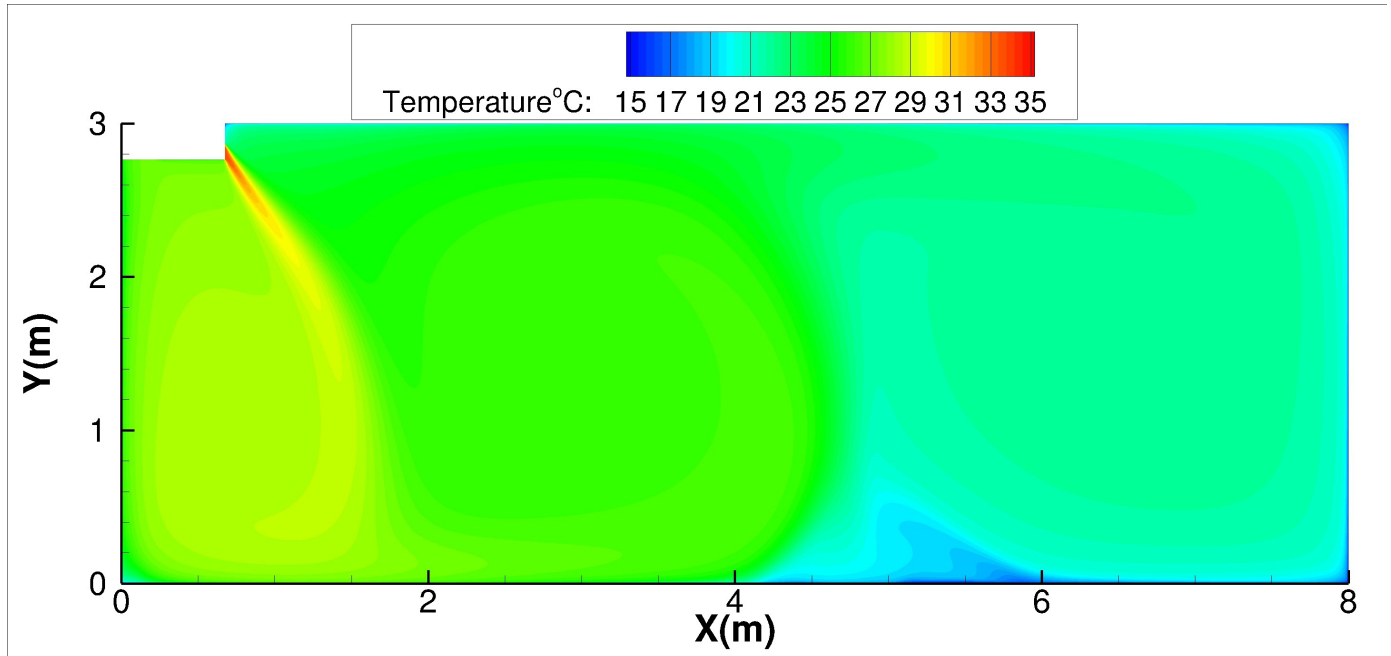

36K-Floor installation:

Discharge Angle 30°

Cooling airflow velocity distributions

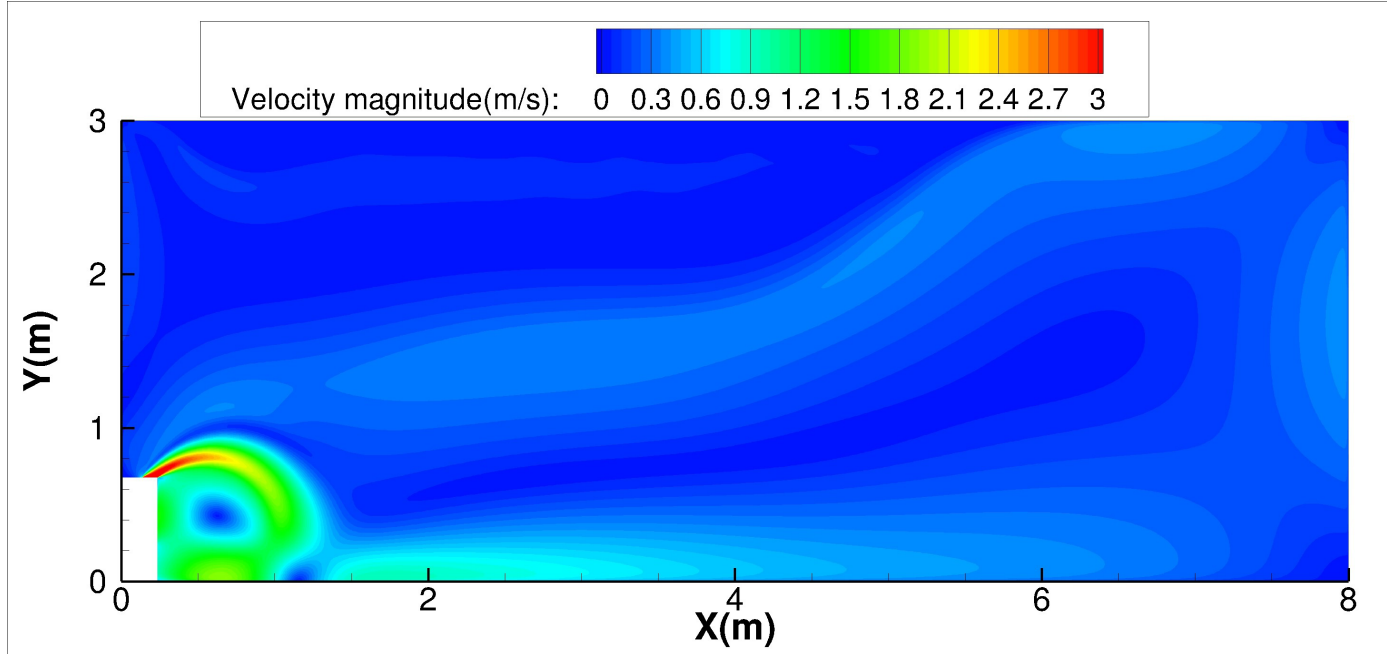

Cooling temperature distributions

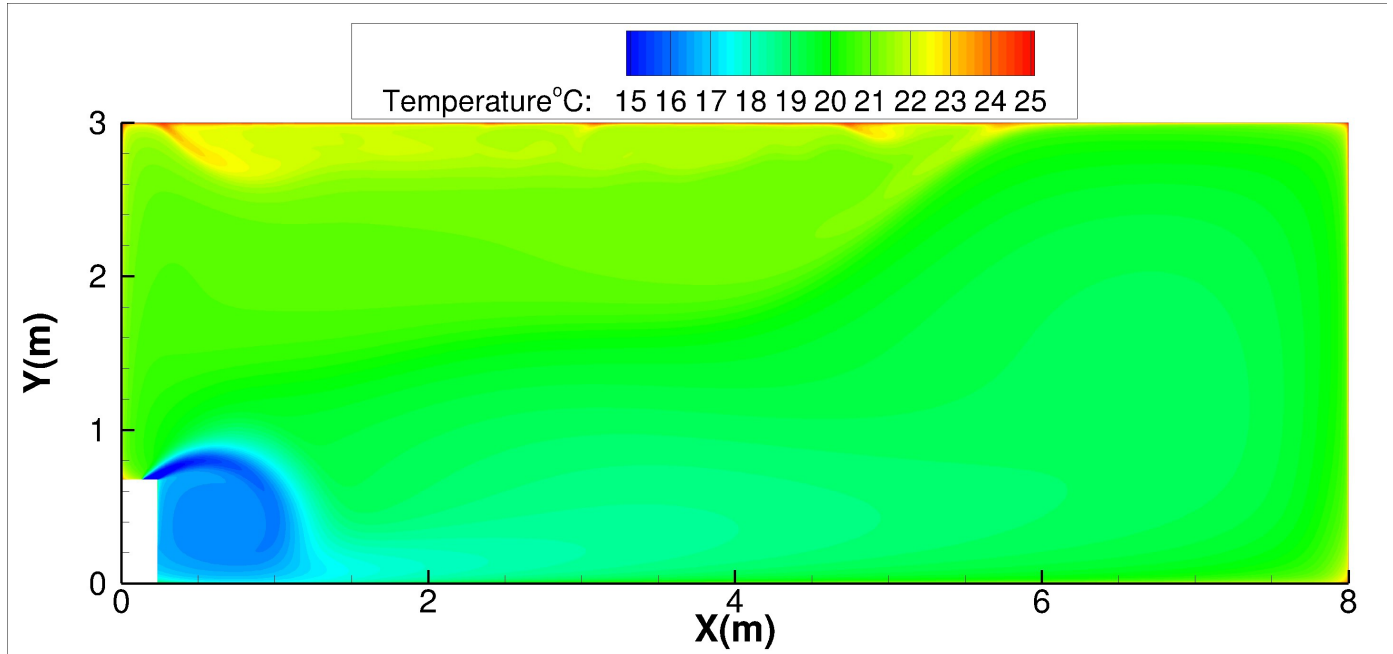

36K-Floor installation:

Discharge Angle 60°

Cooling airflow velocity distributions

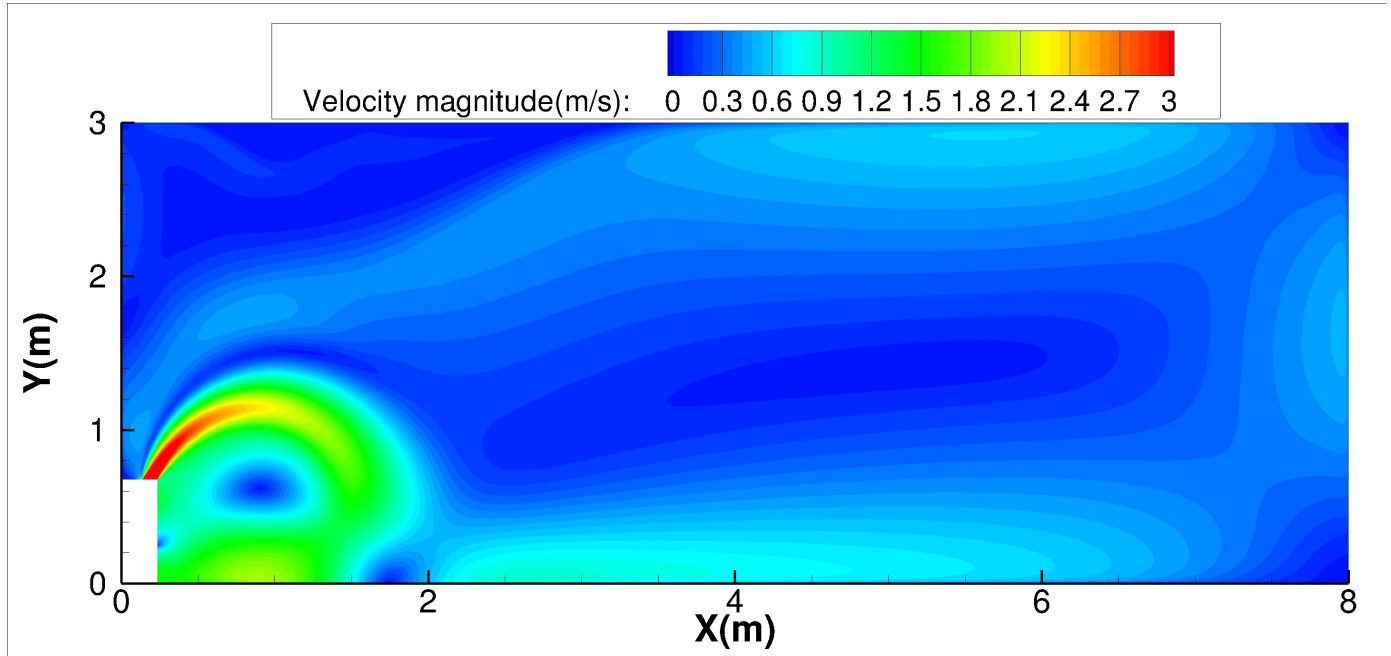

Specifications

Cooling temperature distributions

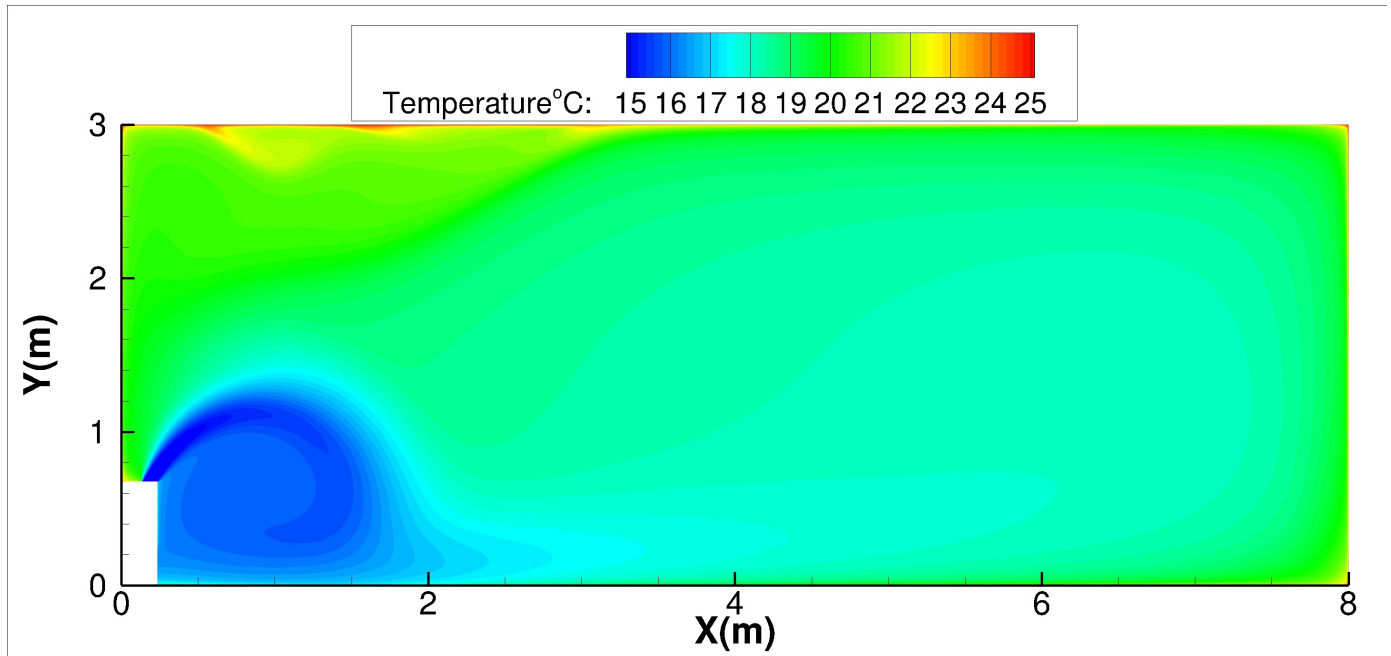

36K-Floor installation:

Discharge Angle 30°

Heating airflow velocity distributions

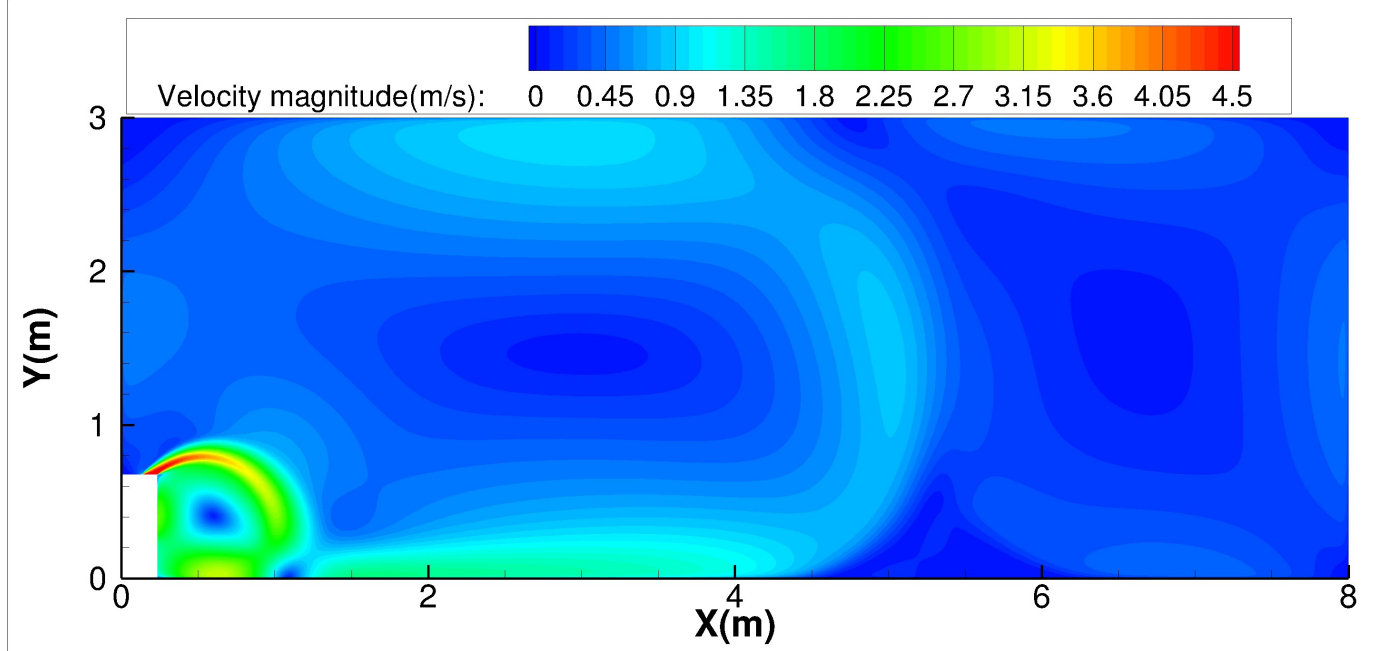

Heating temperature distributions

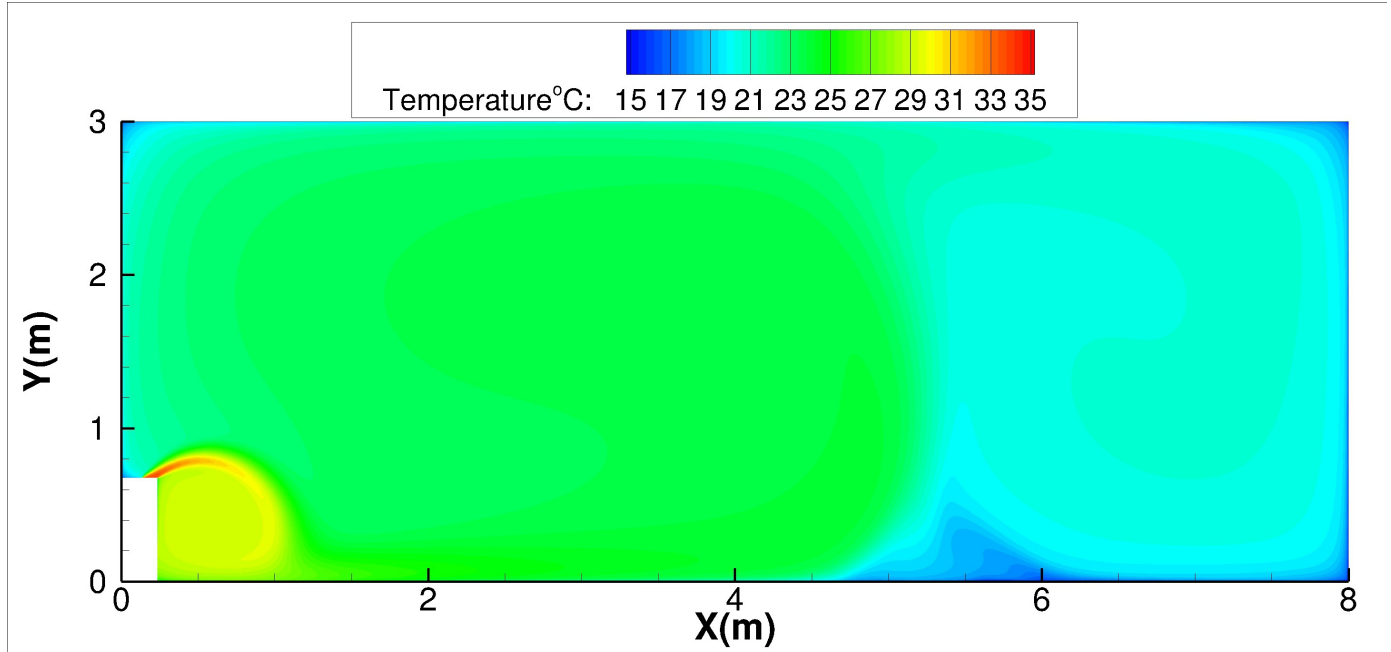

36K-Floor installation:

Discharge Angle 60°

Heating airflow velocity distributions

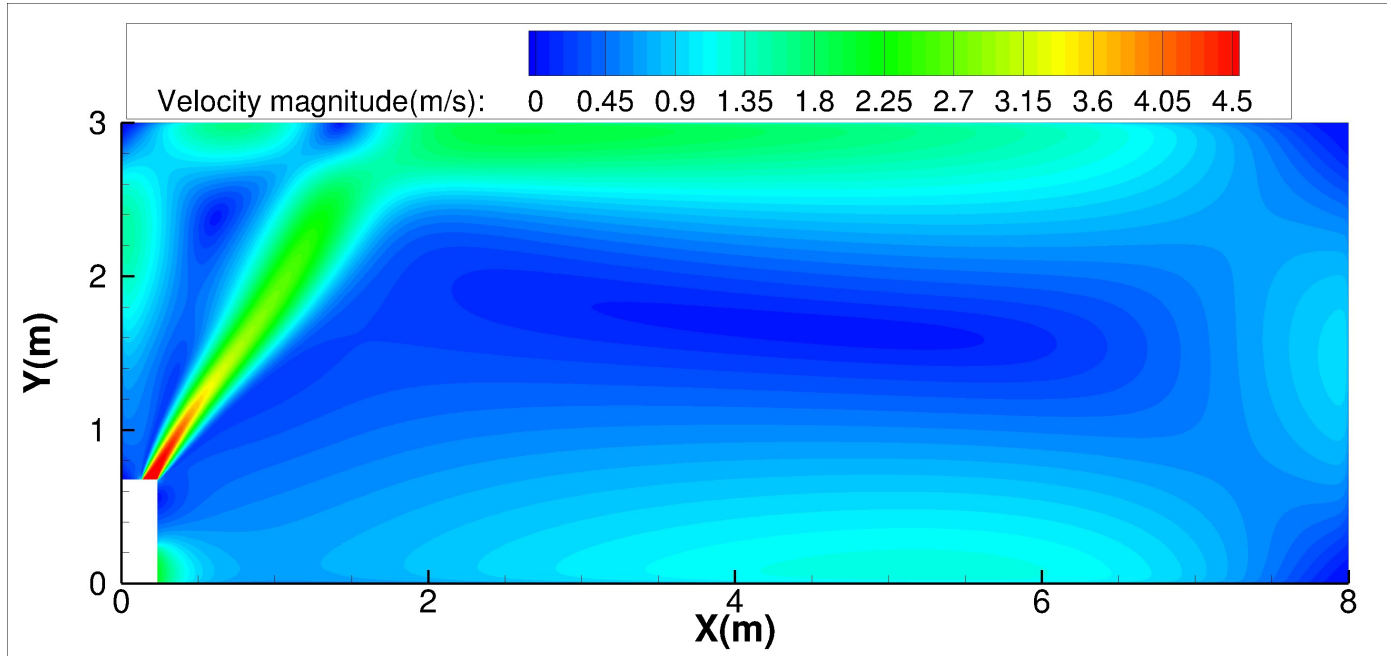

Specifications

Heating temperature distributions

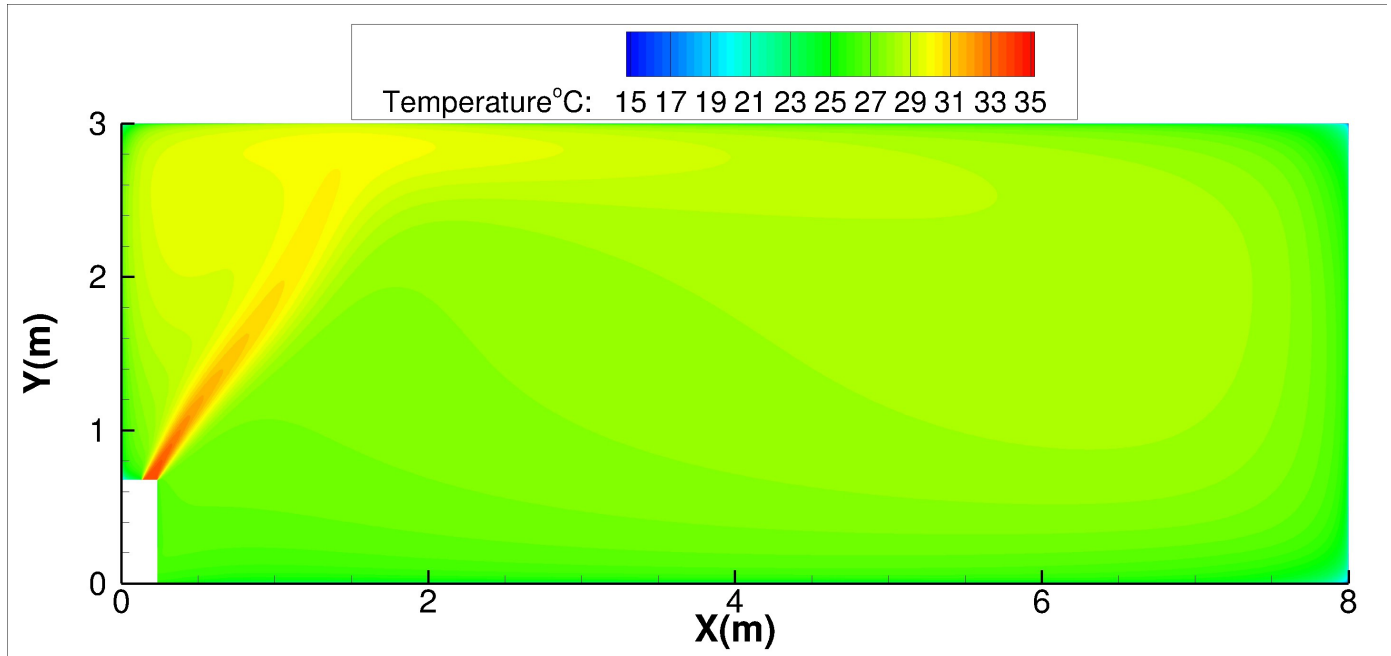

48k-Ceiling installation:

Discharge Angle 30°

Cooling airflow velocity distributions

Specifications

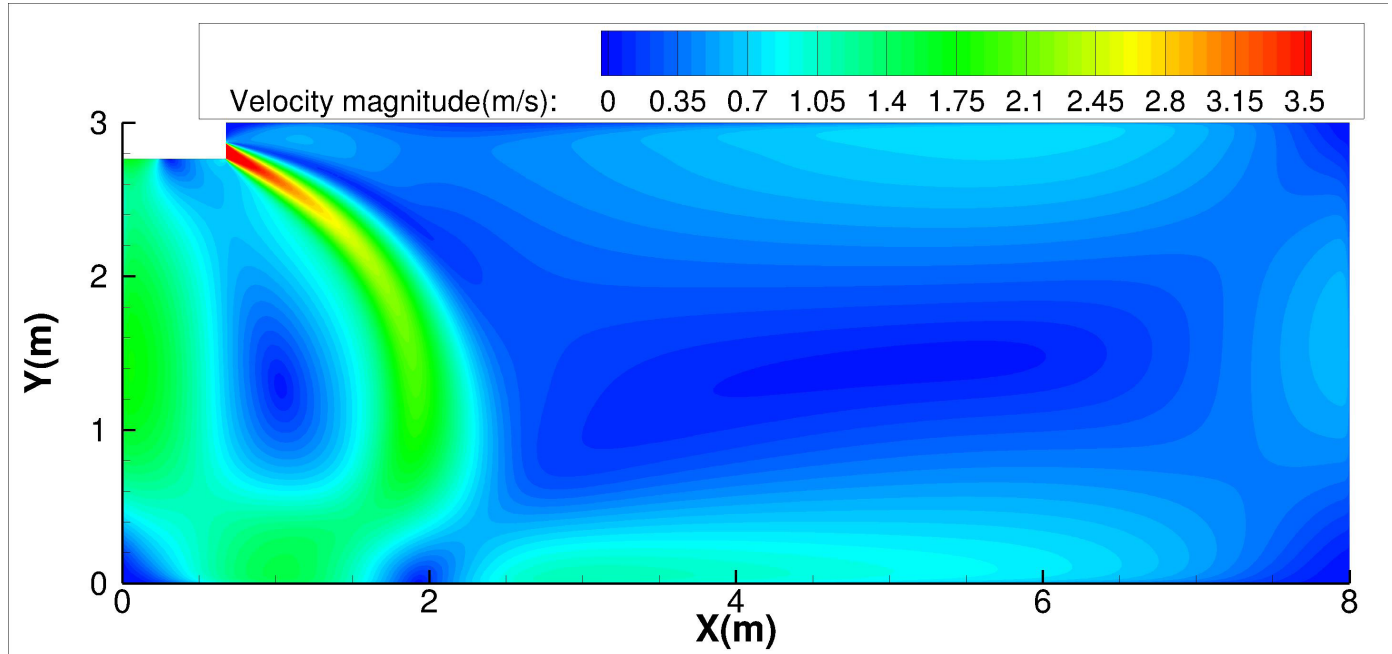

Cooling temperature distributions

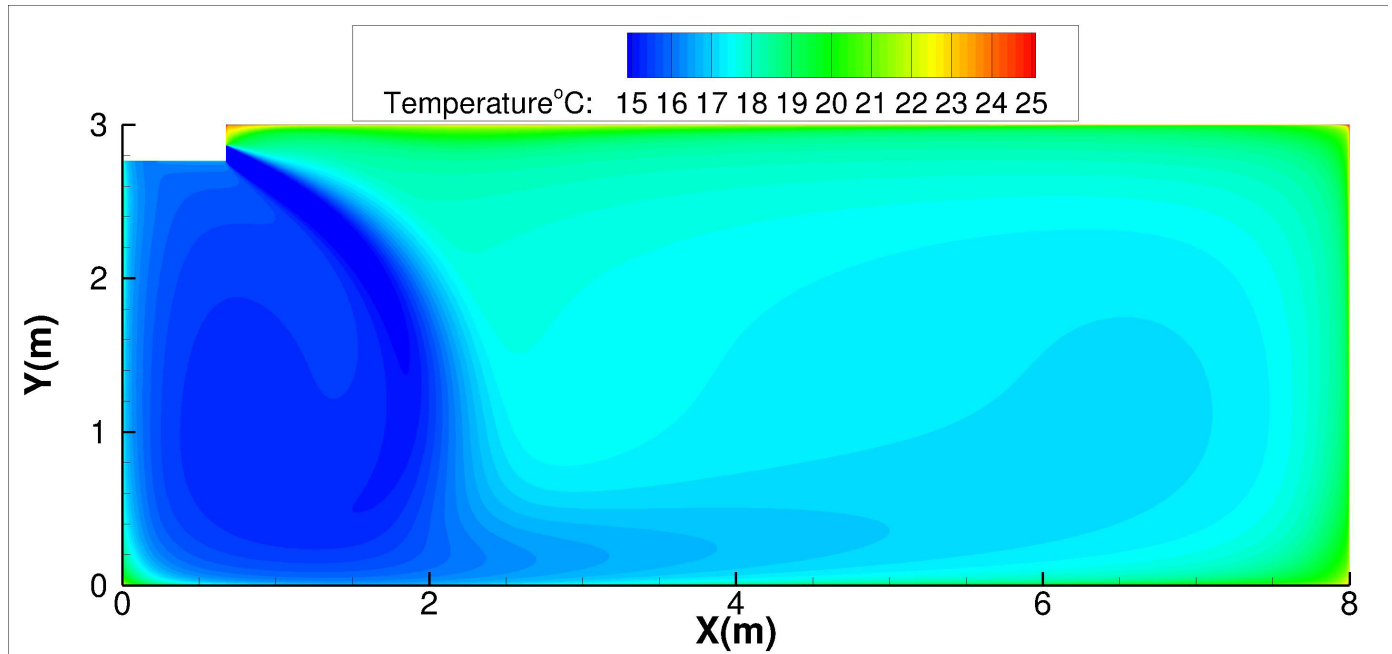

48k-Ceiling installation:

Discharge Angle 60°

Cooling airflow velocity distributions

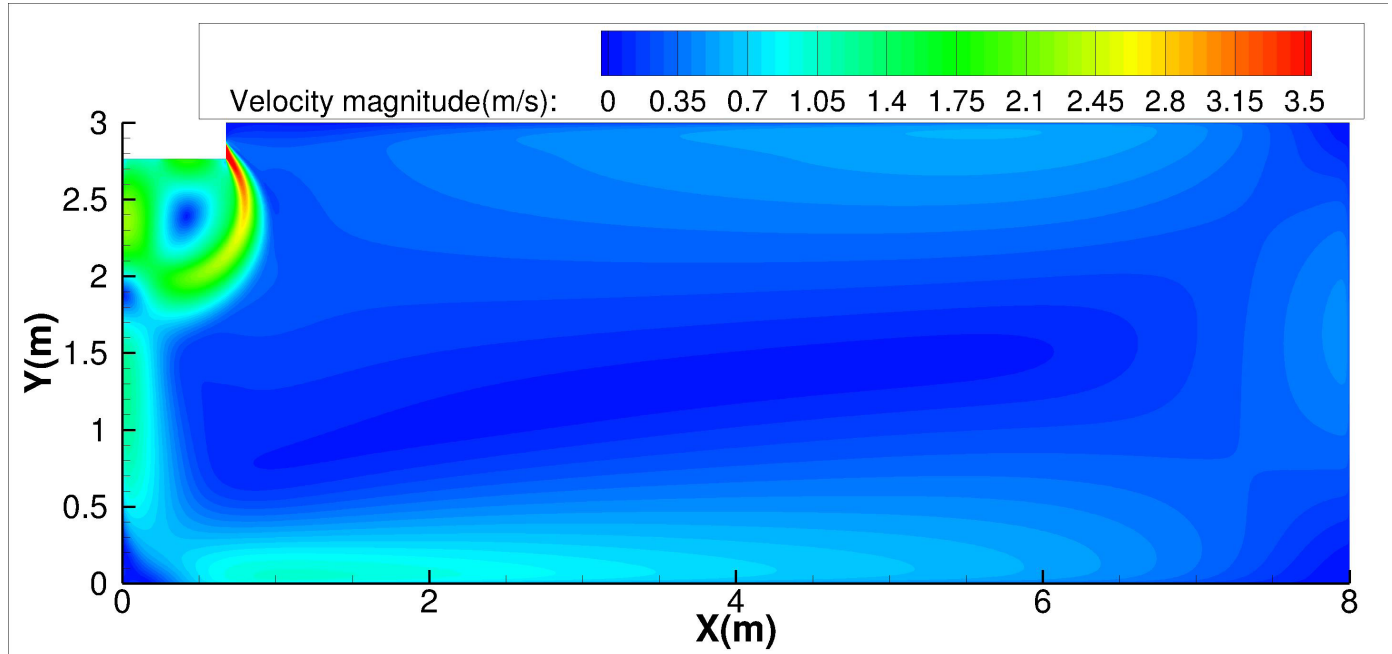

Specifications

Cooling temperature distributions

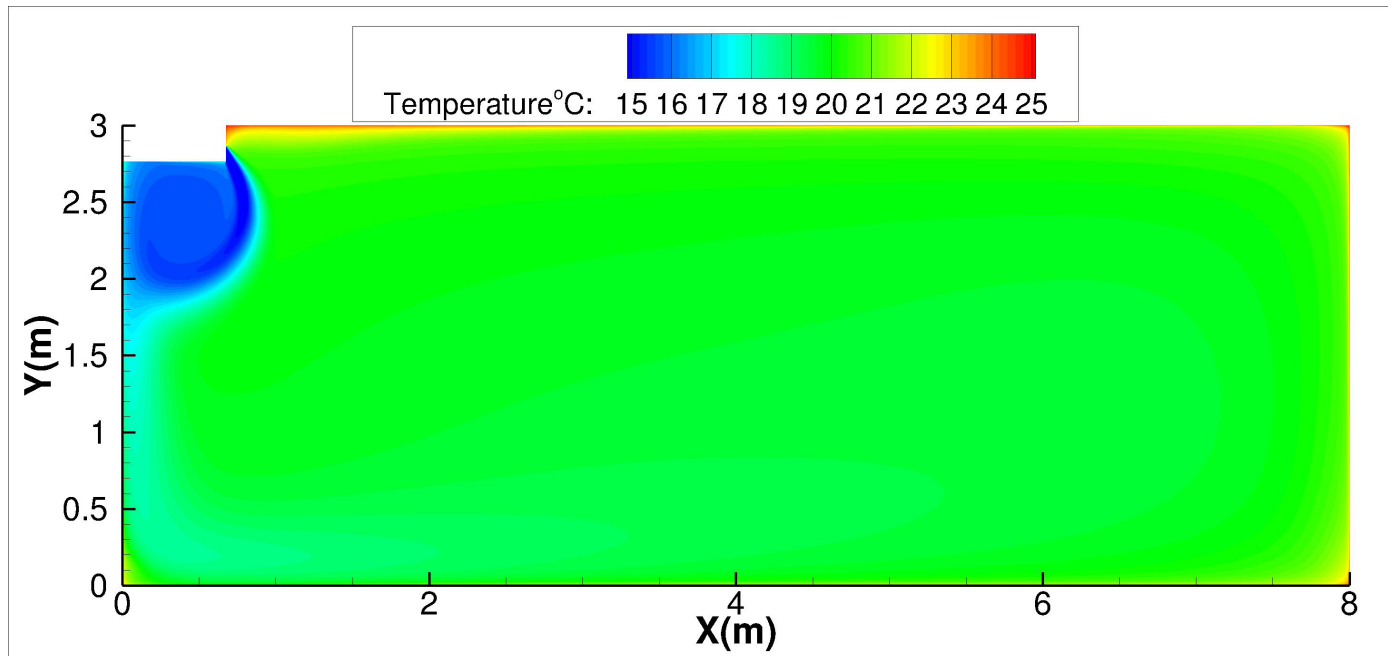

48k-Ceiling installation:

Discharge Angle 30°

Heating airflow velocity distributions

Specifications

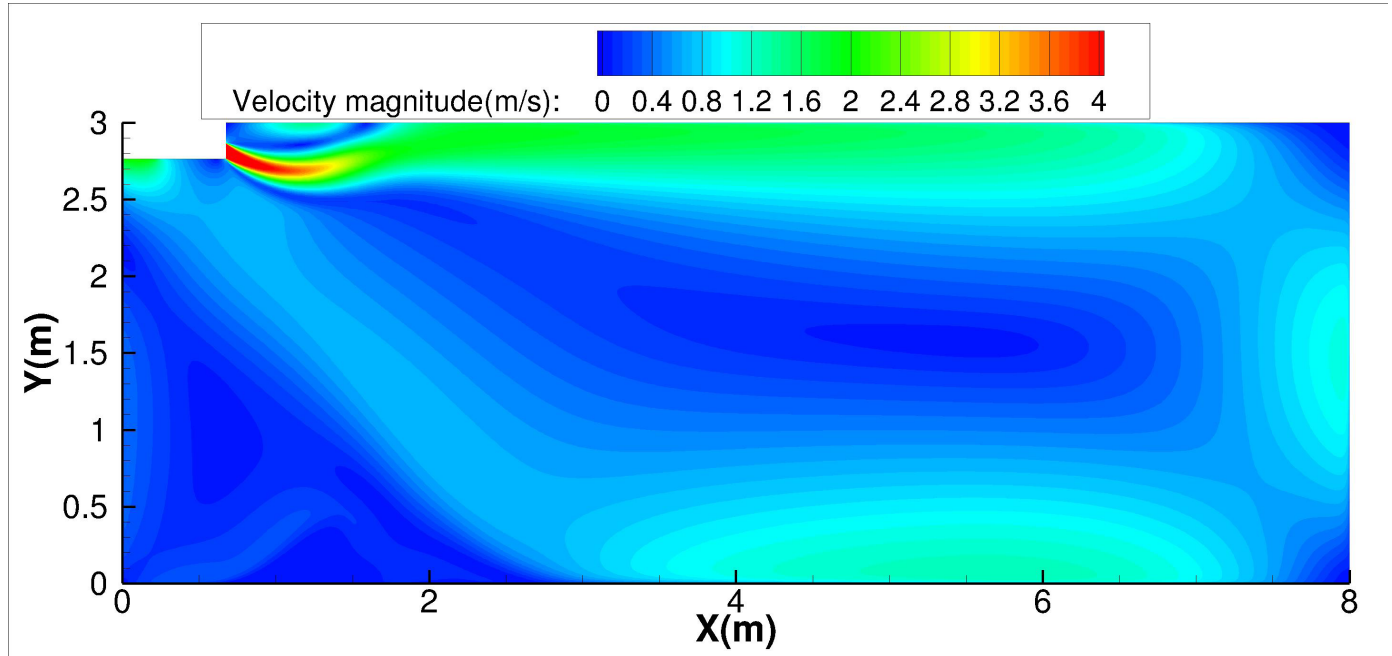

Heating temperature distributions

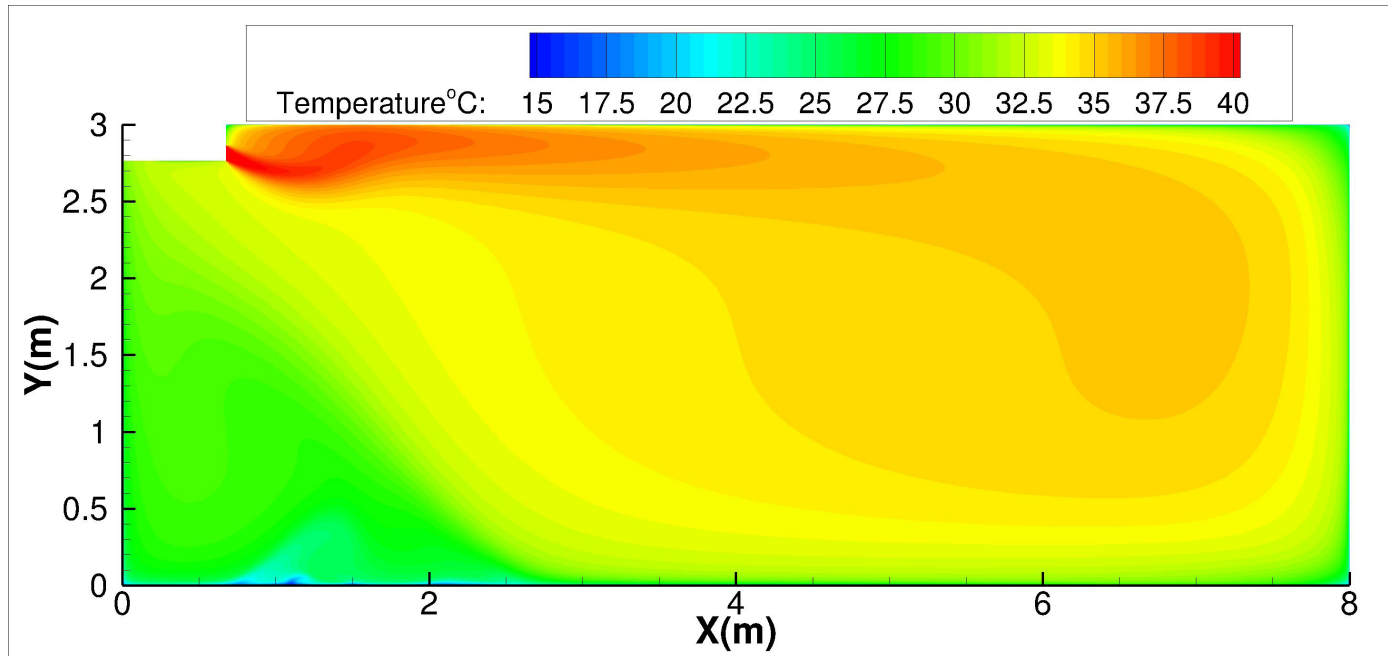

48k-Ceiling installation:

Discharge Angle 60°

Heating airflow velocity distributions

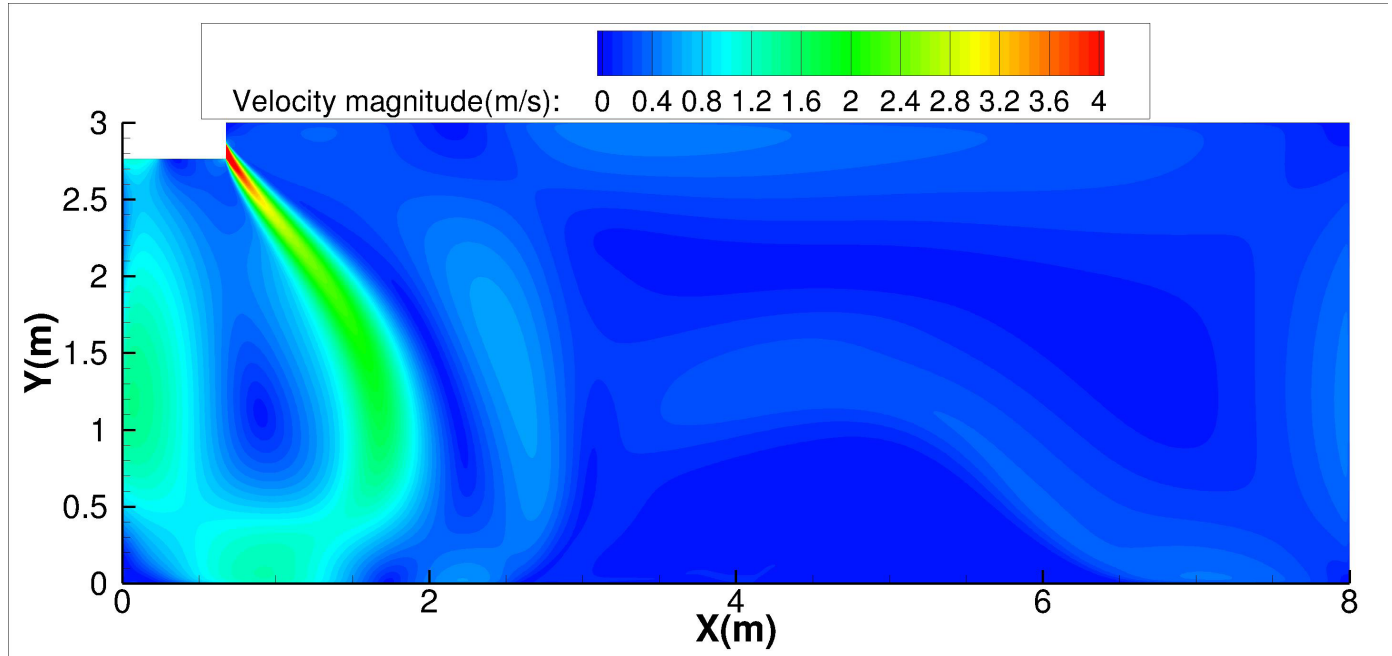

Specifications

Heating temperature distributions

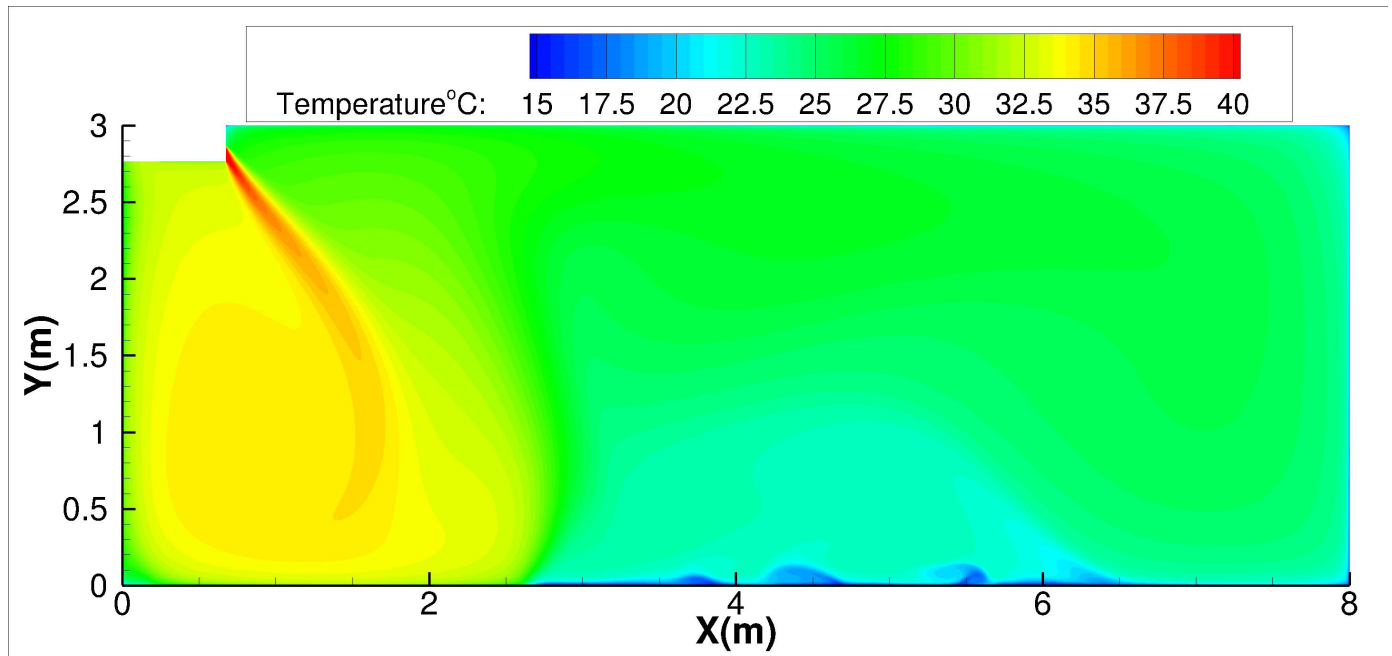

48k-Floor installation:

Discharge Angle 30°

Cooling airflow velocity distributions

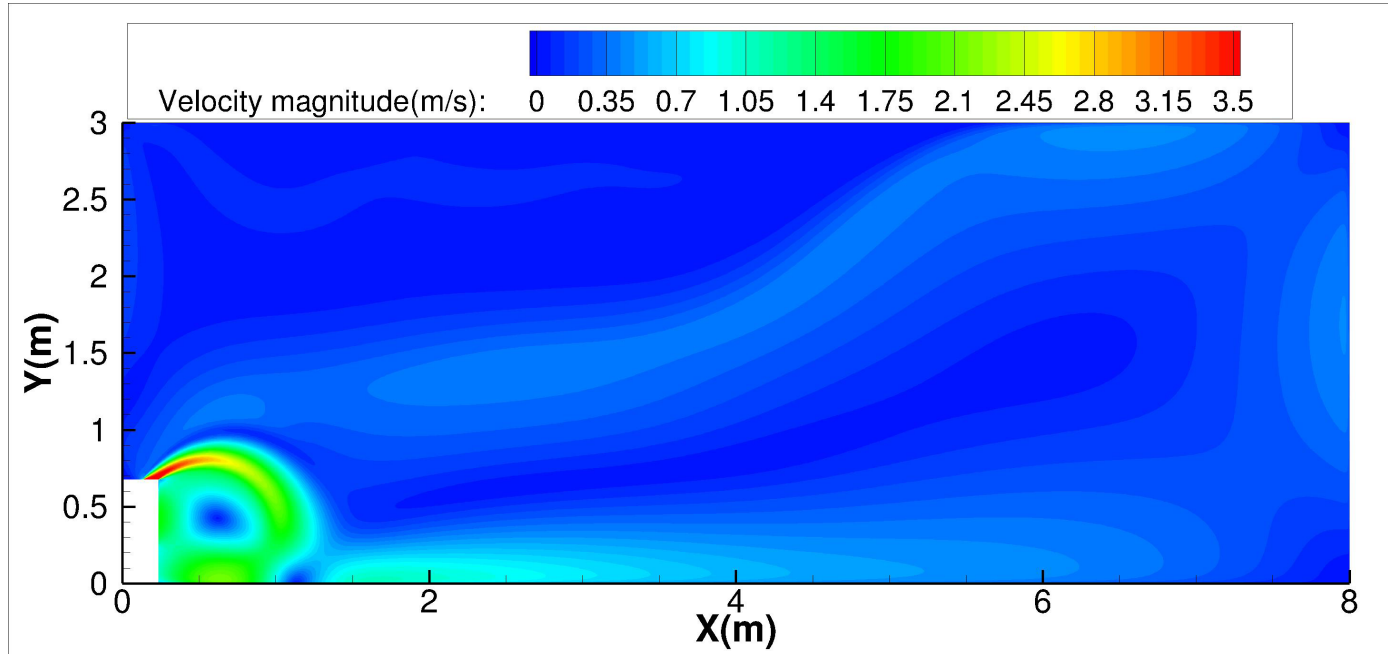

Cooling temperature distributions

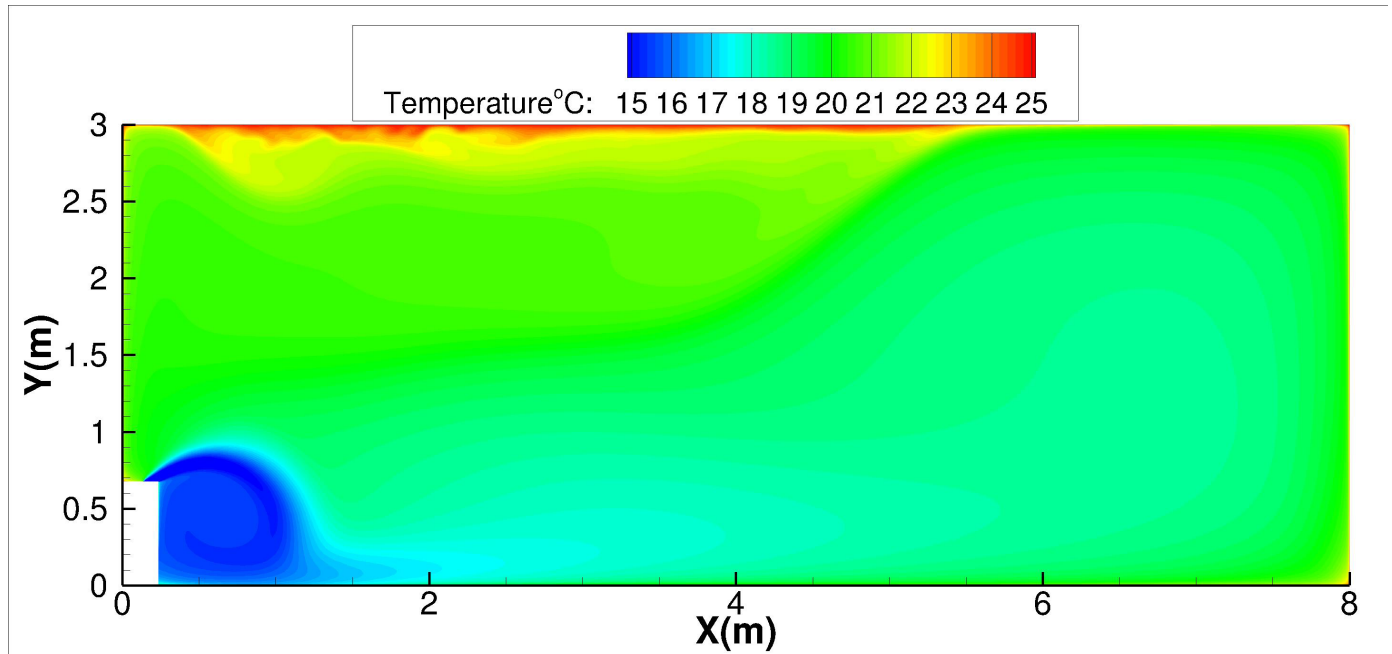

48k-Floor installation:

Discharge Angle 60°

Cooling airflow velocity distributions

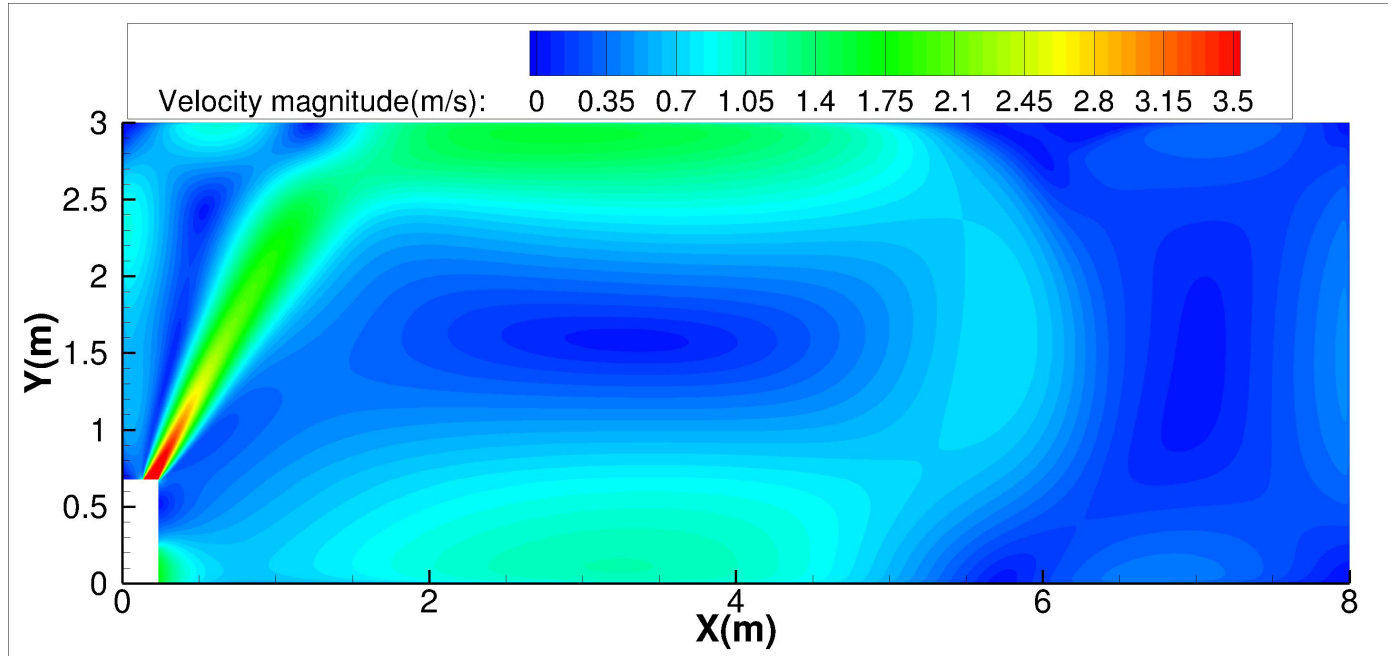

Specifications

Cooling temperature distributions

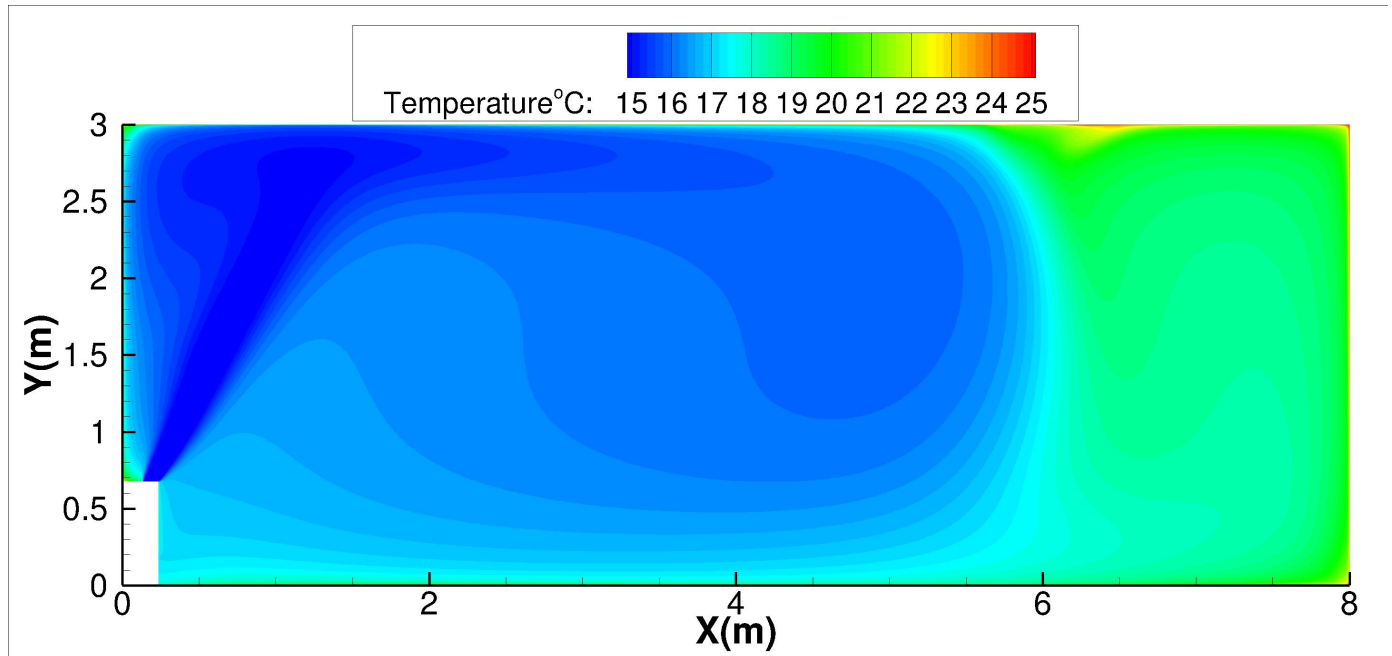

48k-Floor installation:

Discharge Angle 30°

Heating airflow velocity distributions

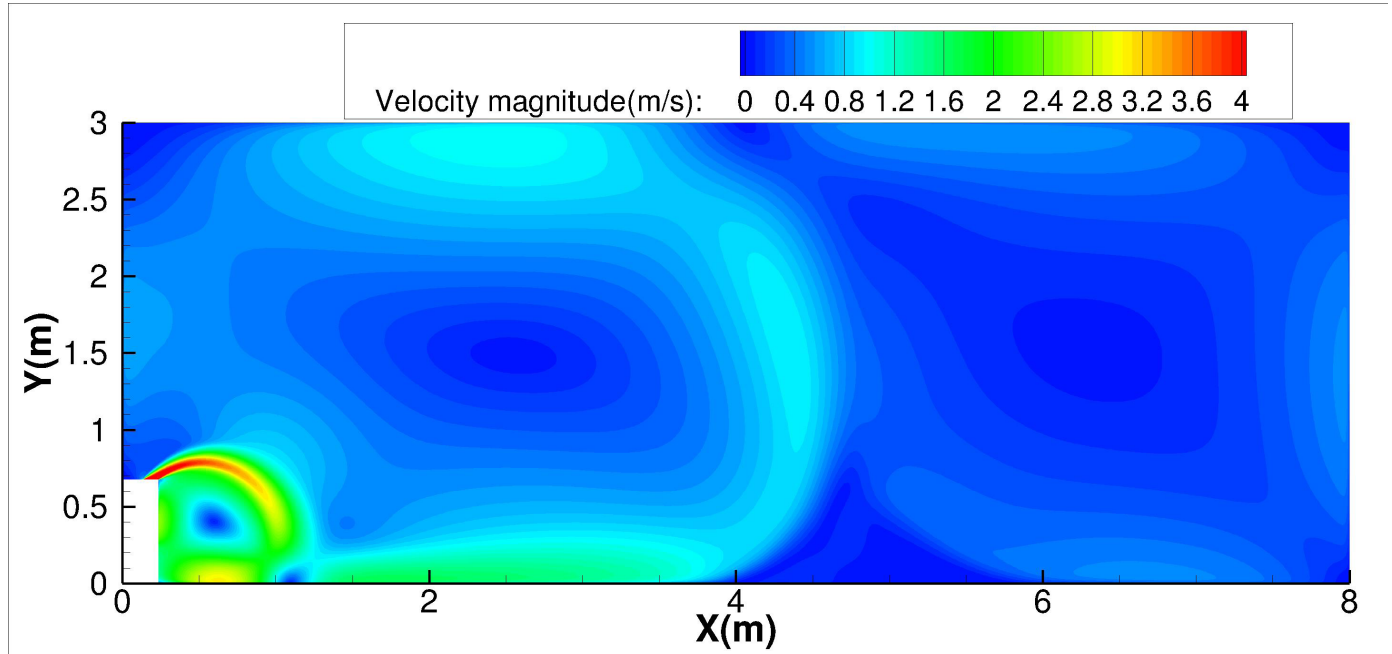

Heating temperature distributions

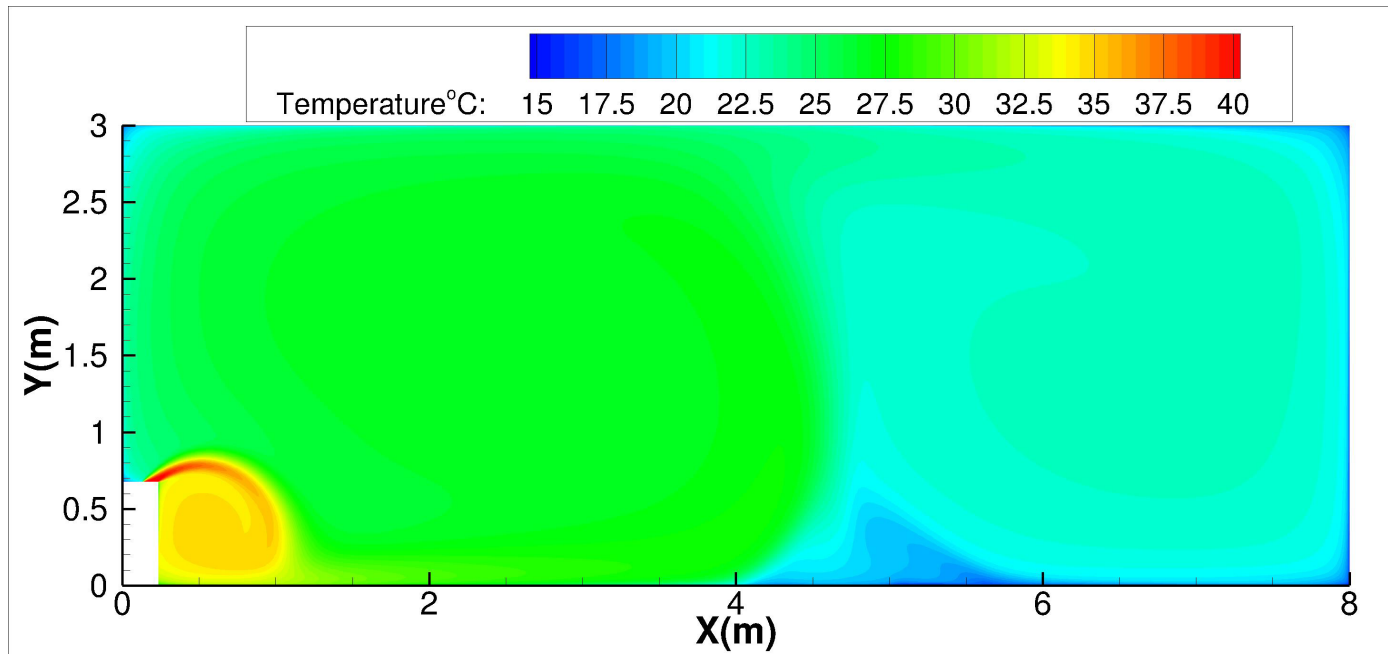

48k-Floor installation:

Discharge Angle 60°

Heating airflow velocity distributions

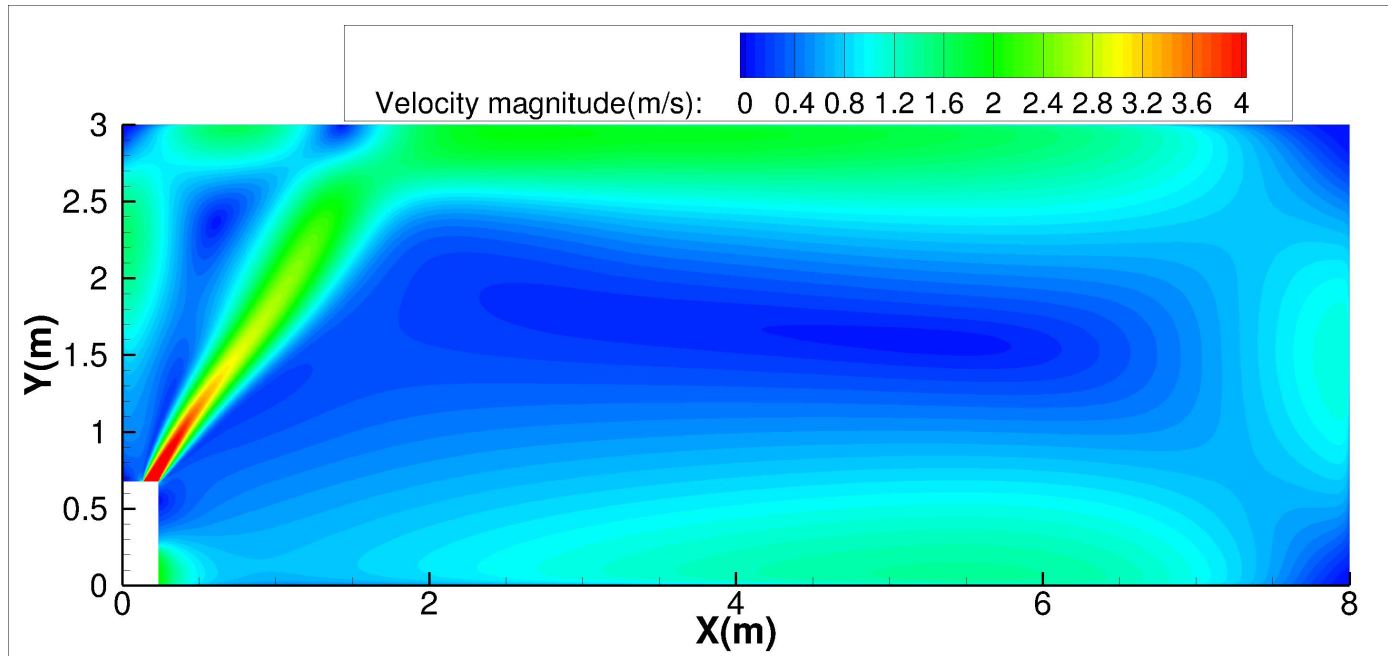

Specifications

Heating temperature distributions

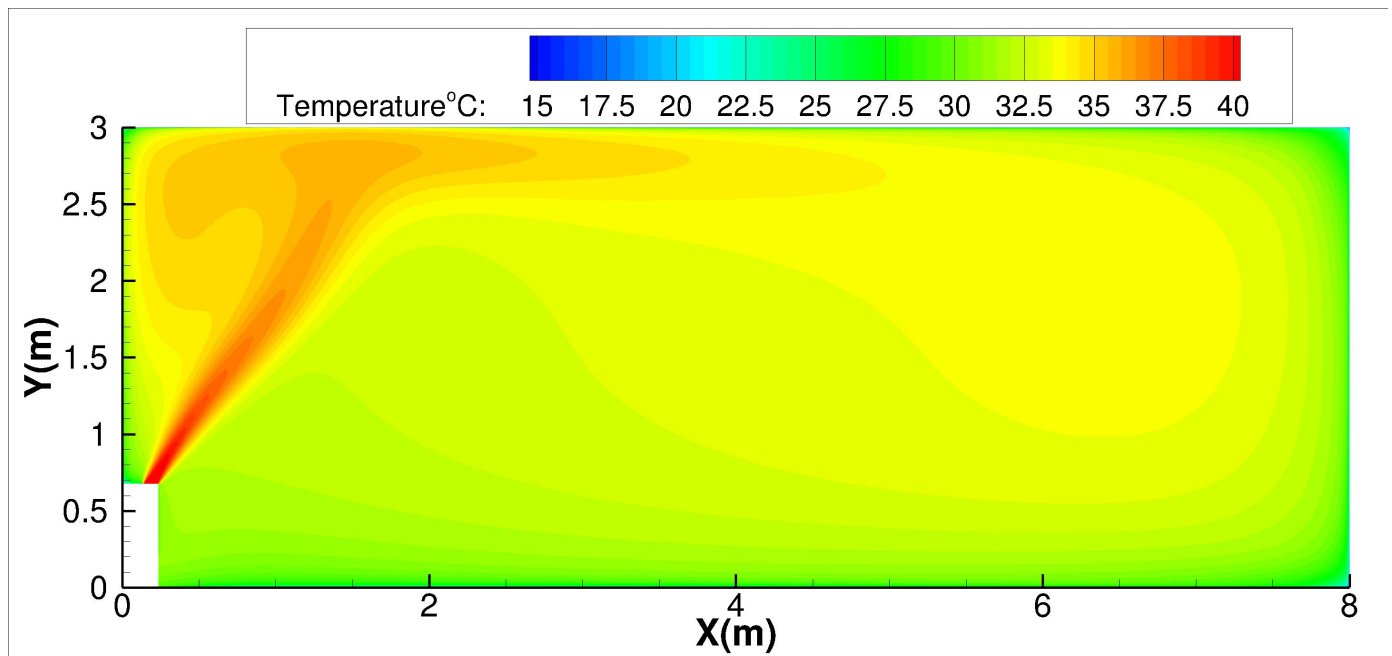

55k-Ceiling installation:

Discharge Angle 30°

Cooling airflow velocity distributions

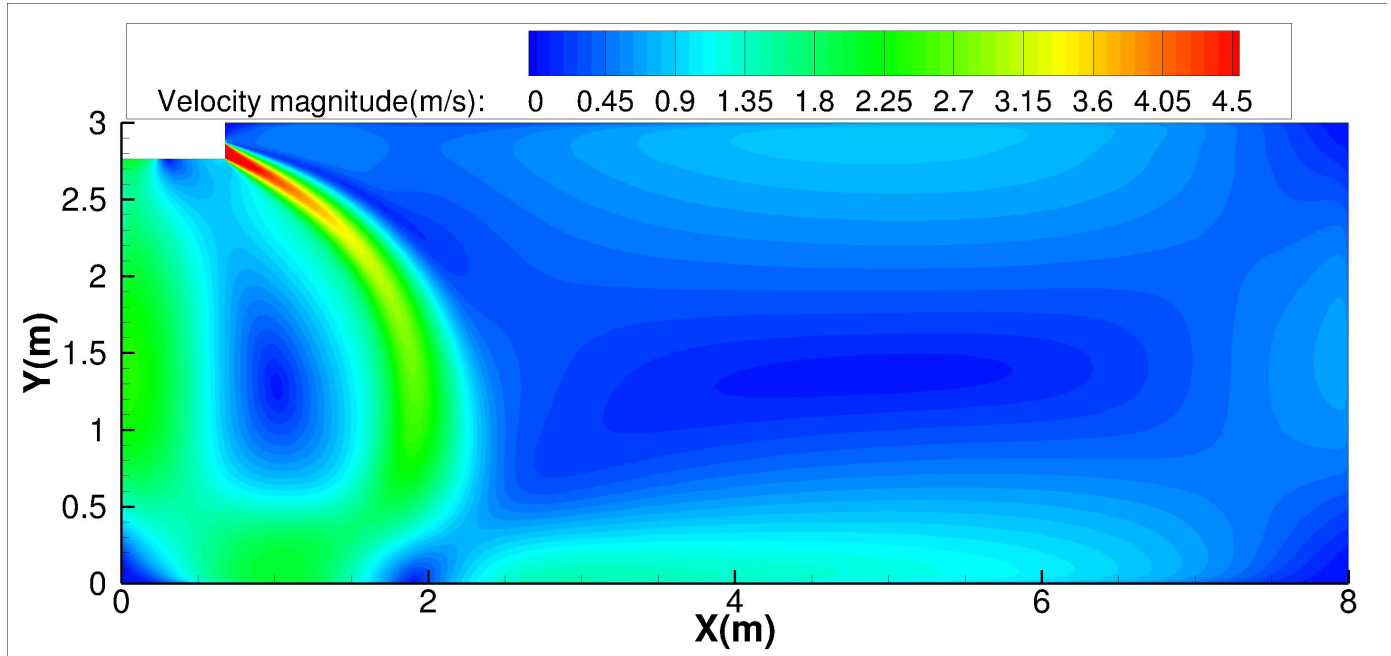

Cooling temperature distributions

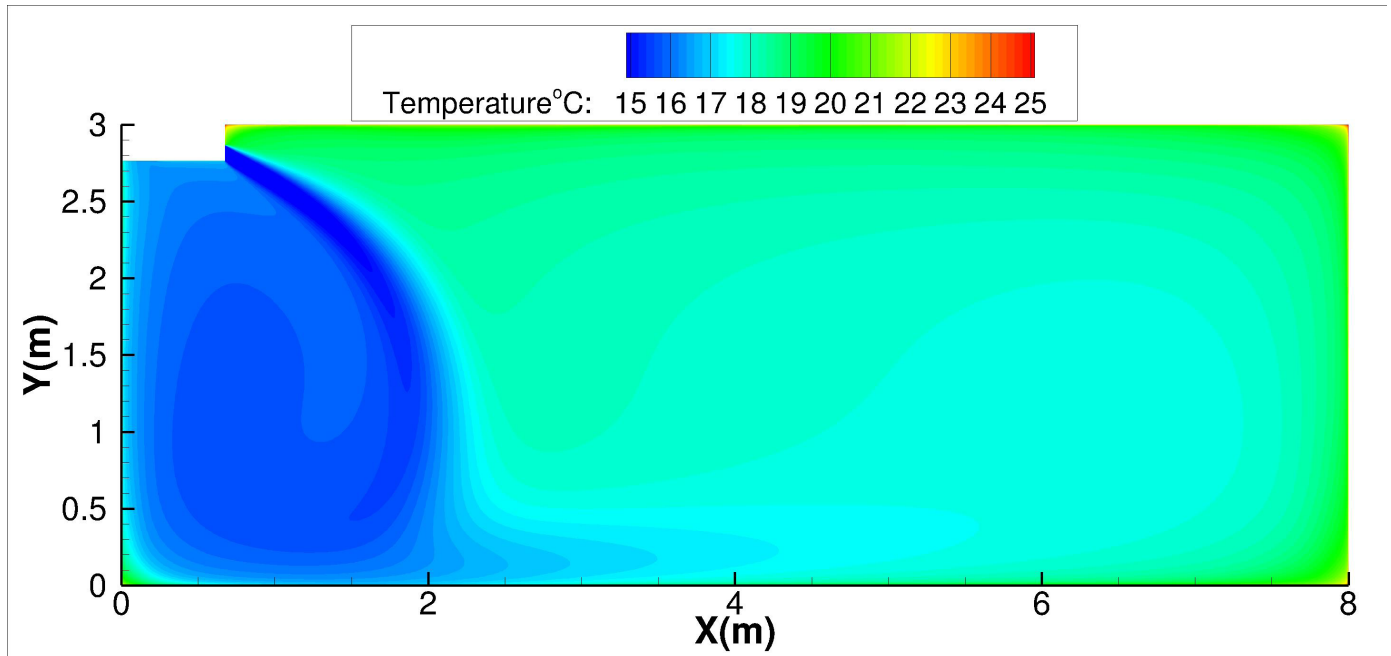

55k-Ceiling installation:

Discharge Angle 60°

Cooling airflow velocity distributions

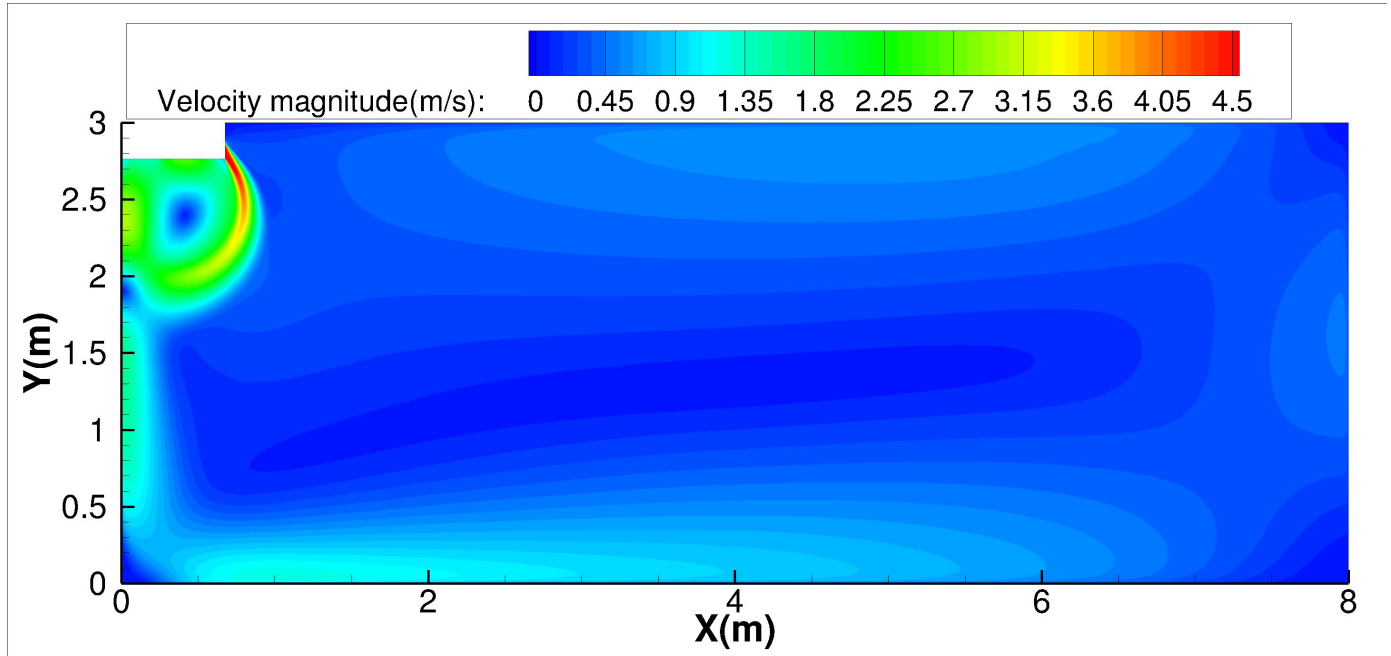

Specifications

Cooling temperature distributions

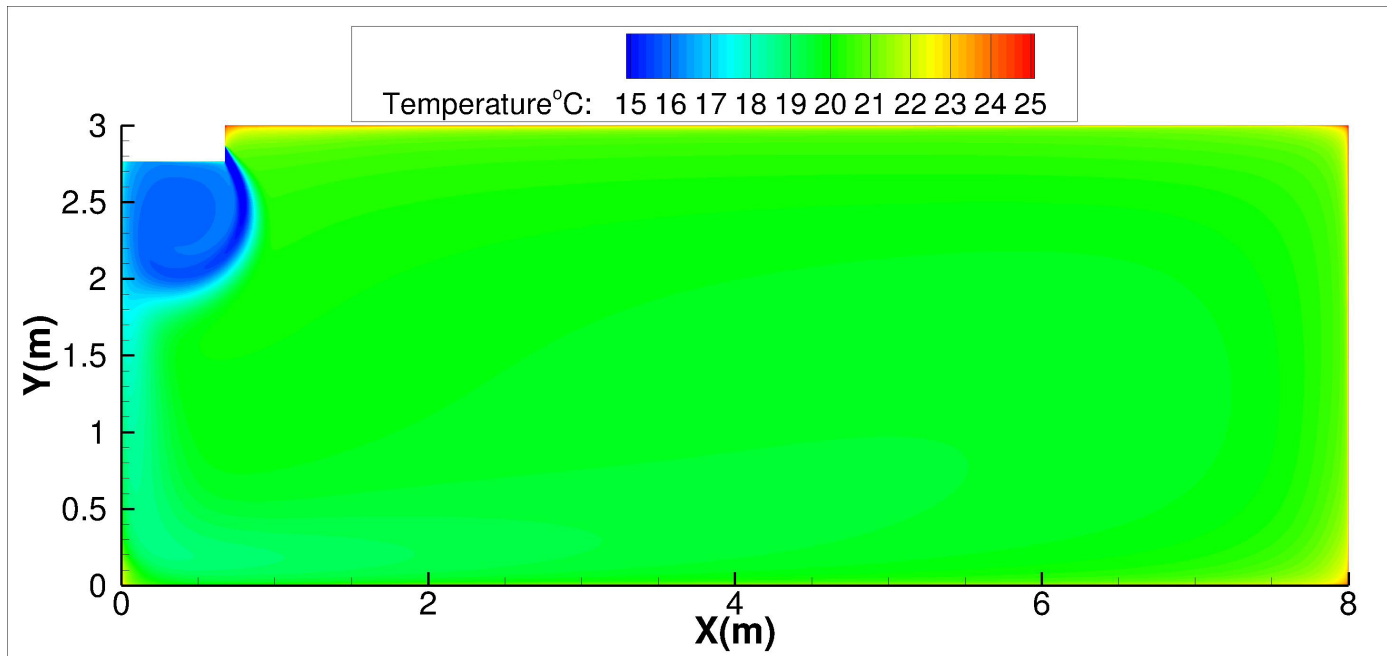

55k-Ceiling installation:

Discharge Angle 30°

Heating airflow velocity distributions

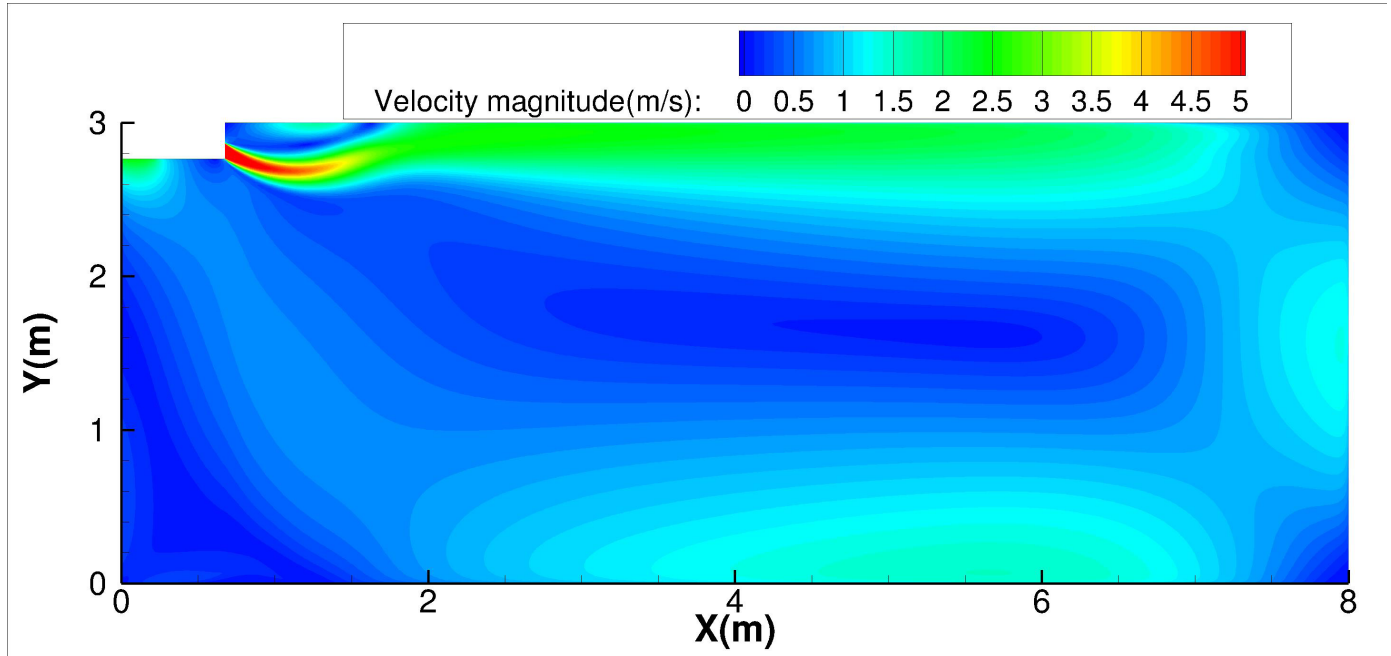

Heating temperature distributions

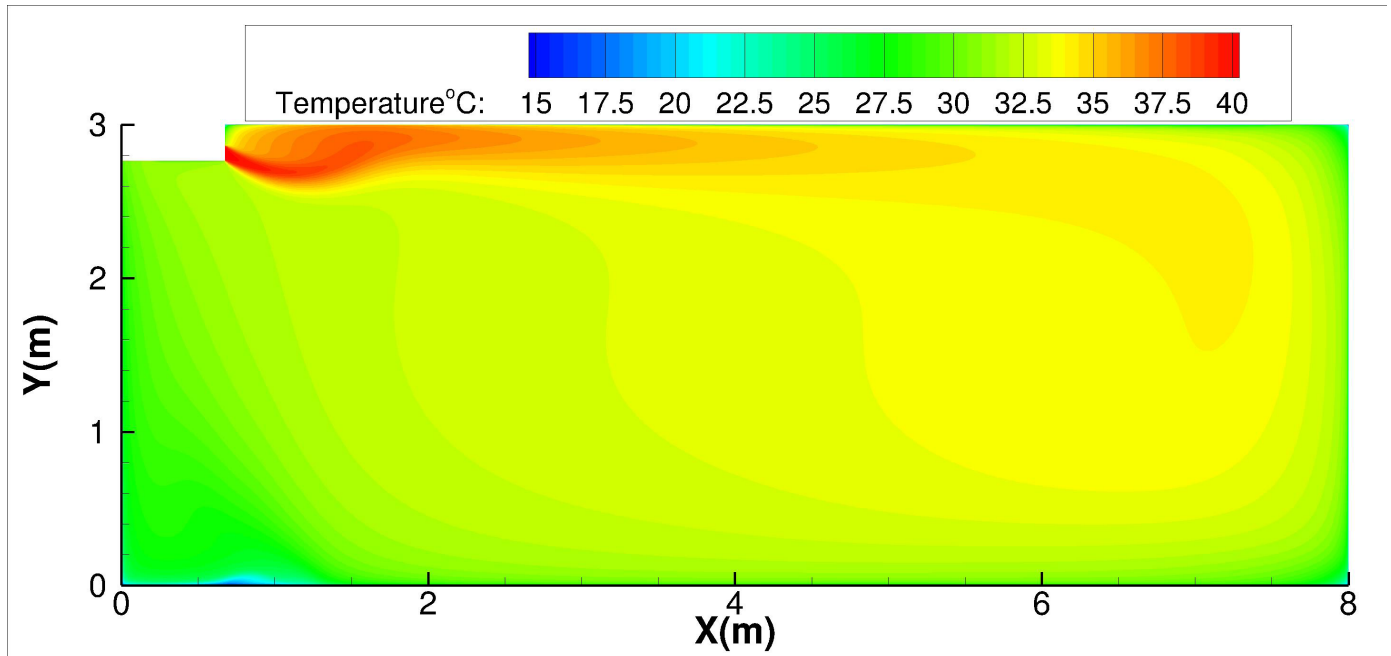

55k-Ceiling installation:

Discharge Angle 60°

Heating airflow velocity distributions

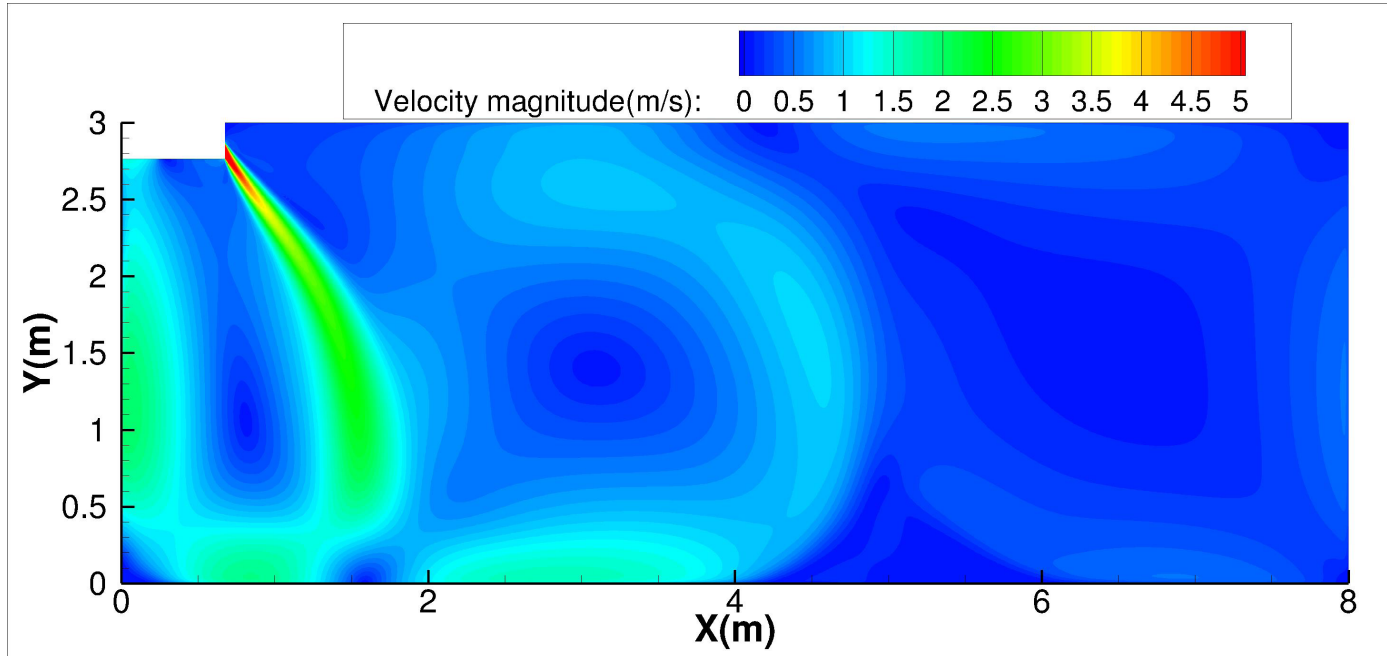

Specifications

Heating temperature distributions

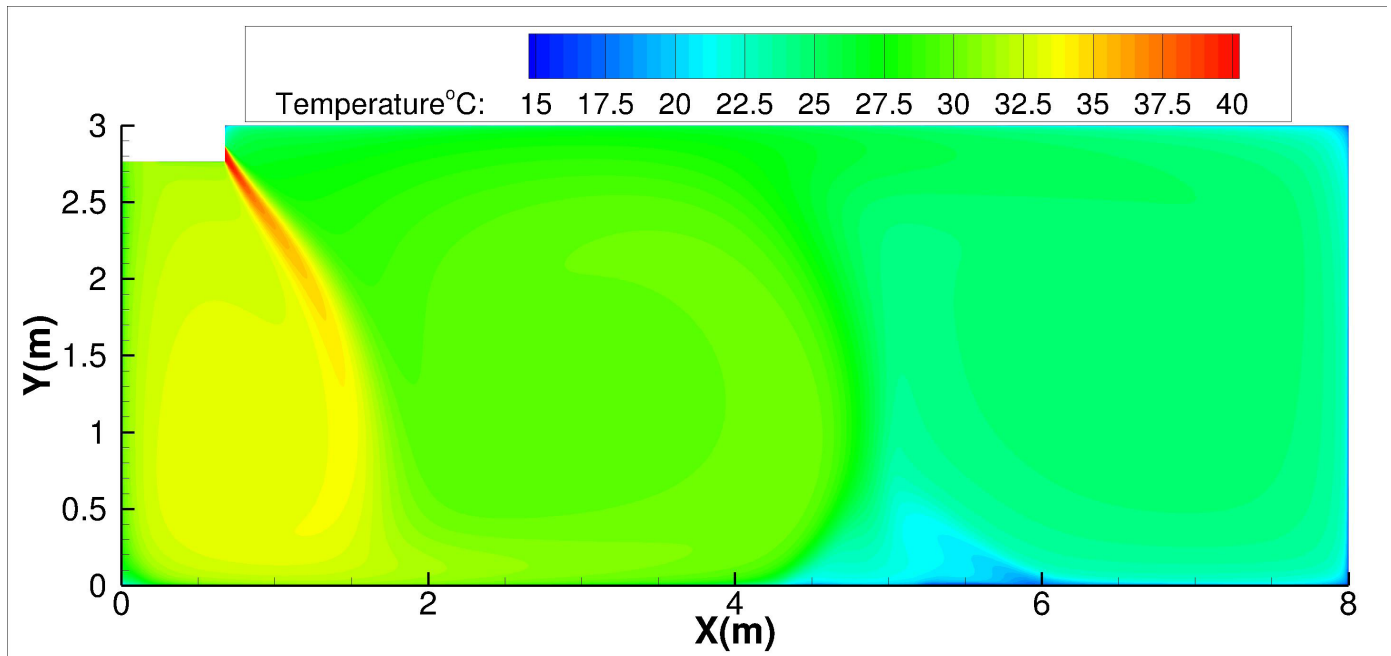

55k-Floor installation:

Discharge Angle 30°

Cooling airflow velocity distributions

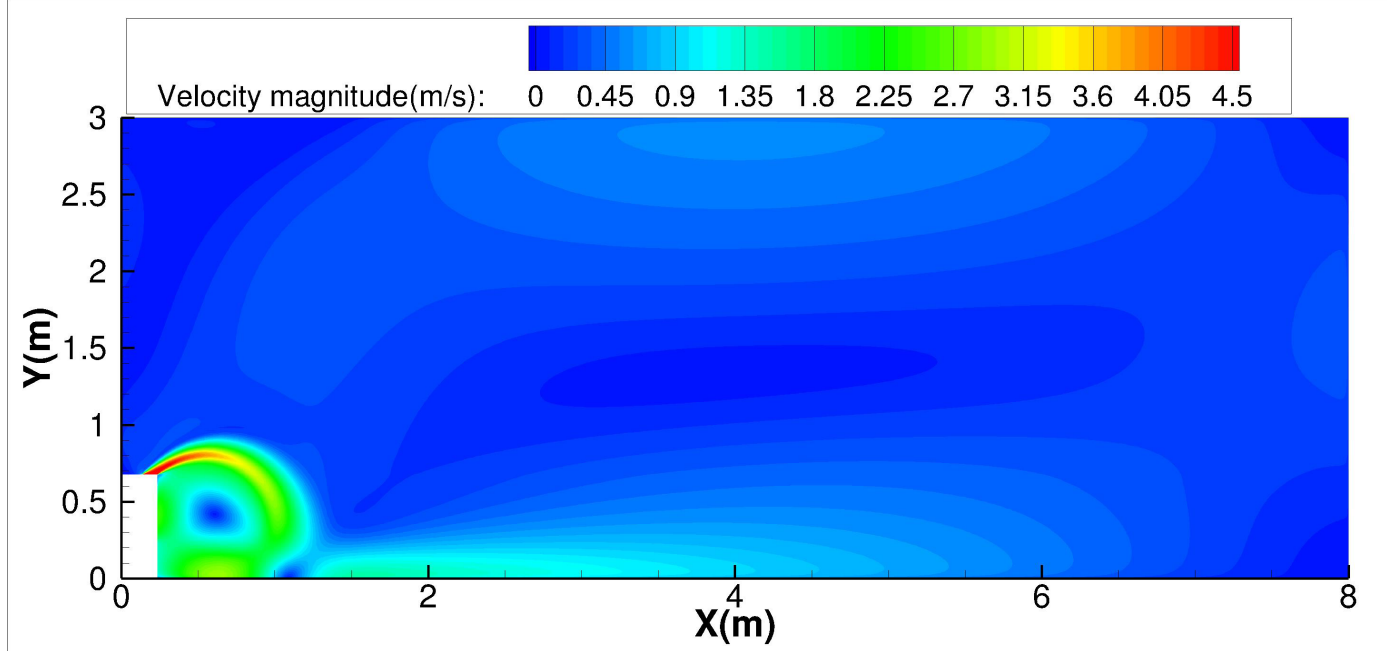

Cooling temperature distributions

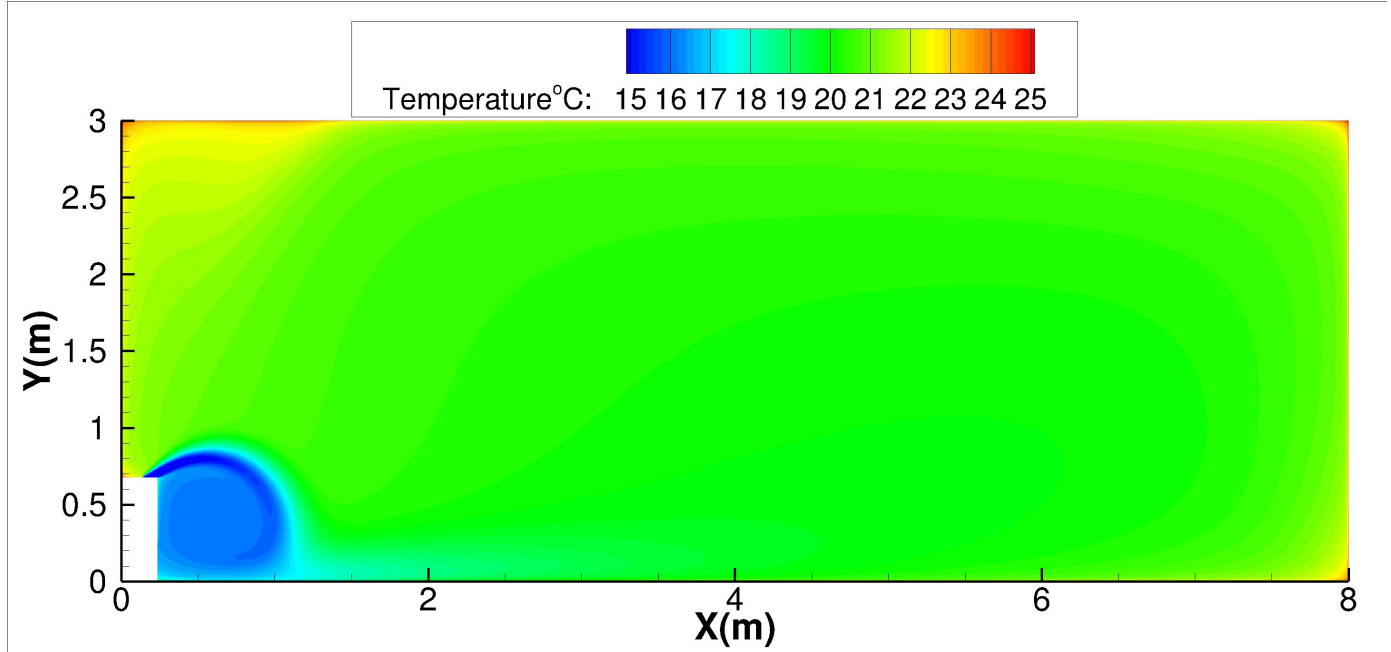

55k-Floor installation:

Discharge Angle 60°

Cooling airflow velocity distributions

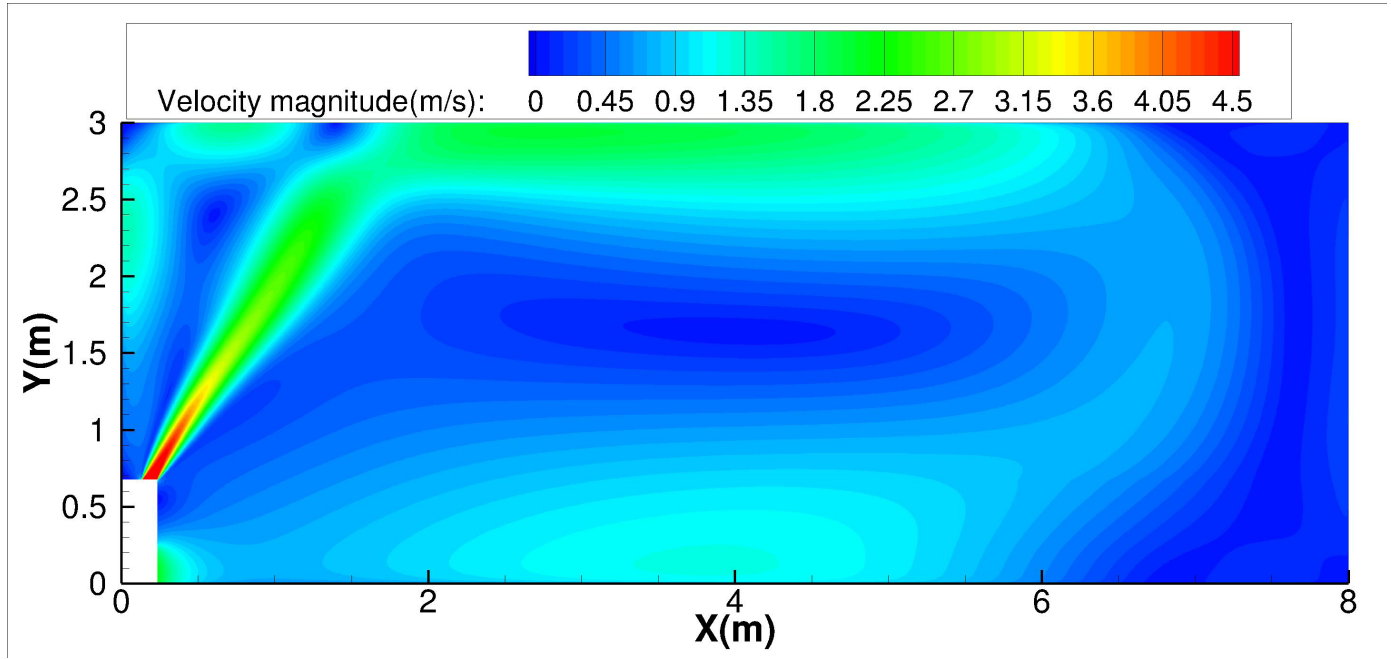

Specifications

Cooling temperature distributions

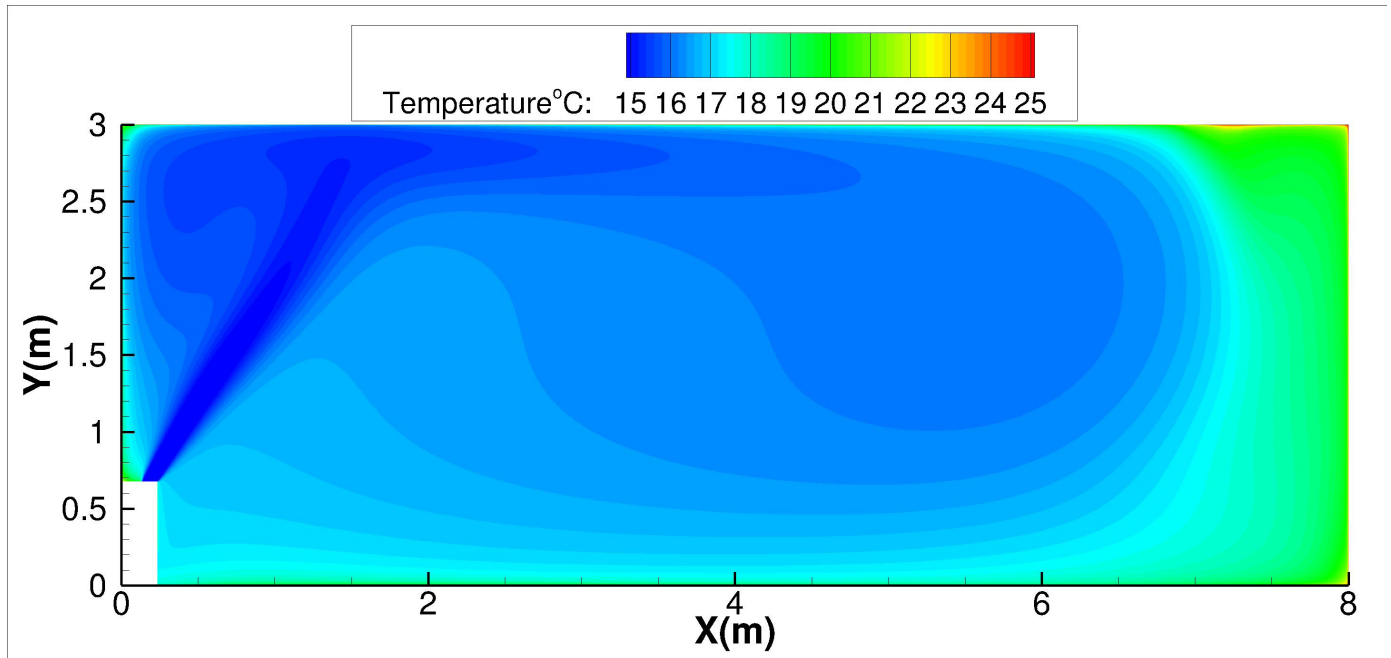

55k-Floor installation:

Discharge Angle 30°

Heating airflow velocity distributions

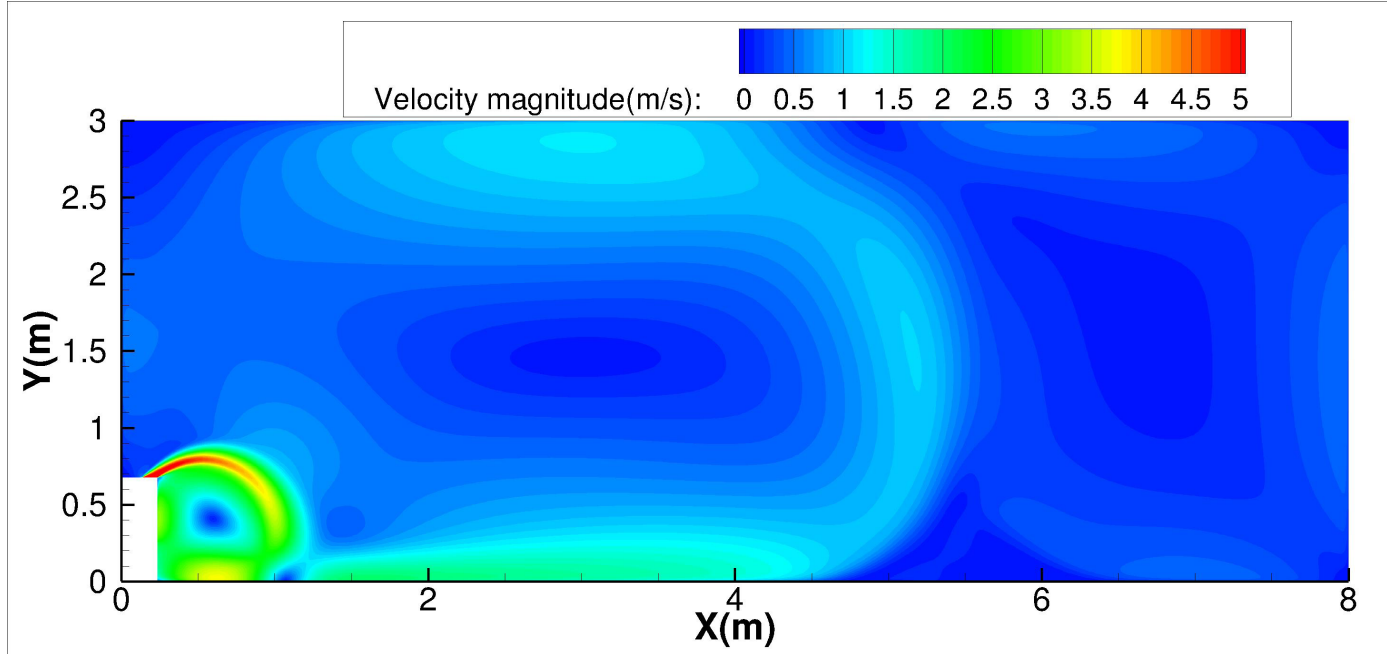

Heating temperature distributions

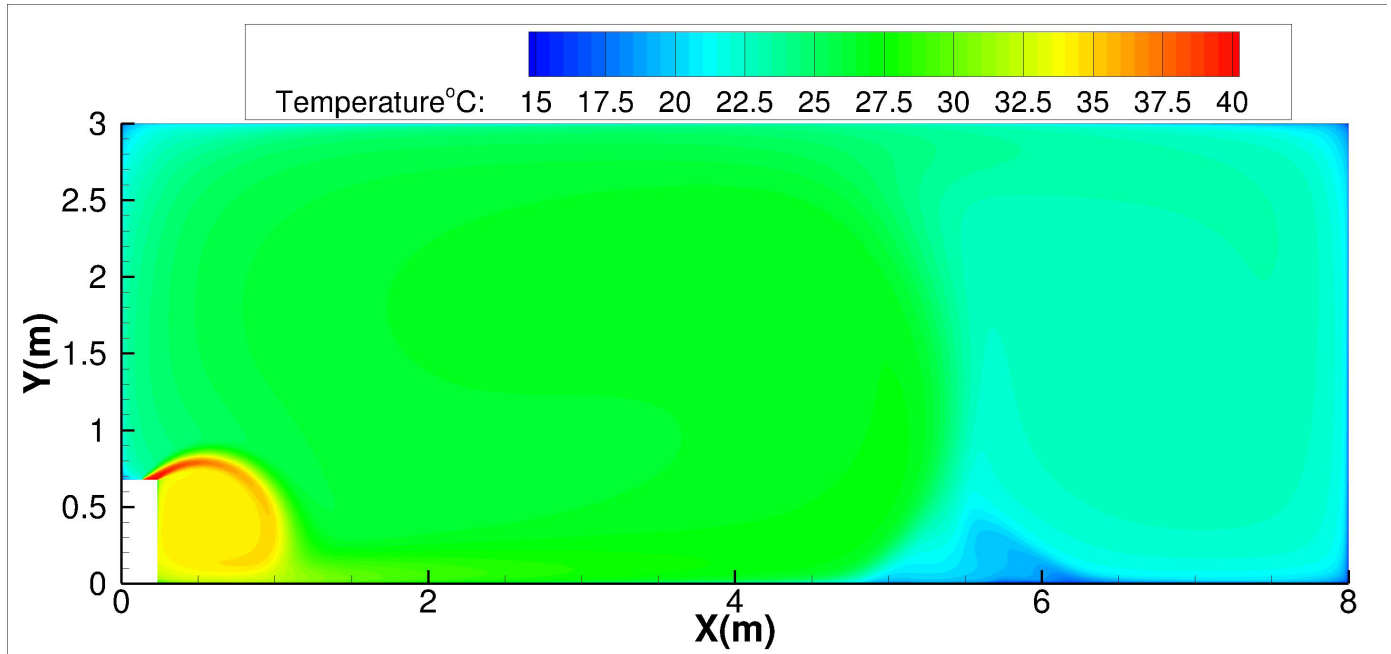

55k-Floor installation:

Discharge Angle 60°

Heating airflow velocity distributions

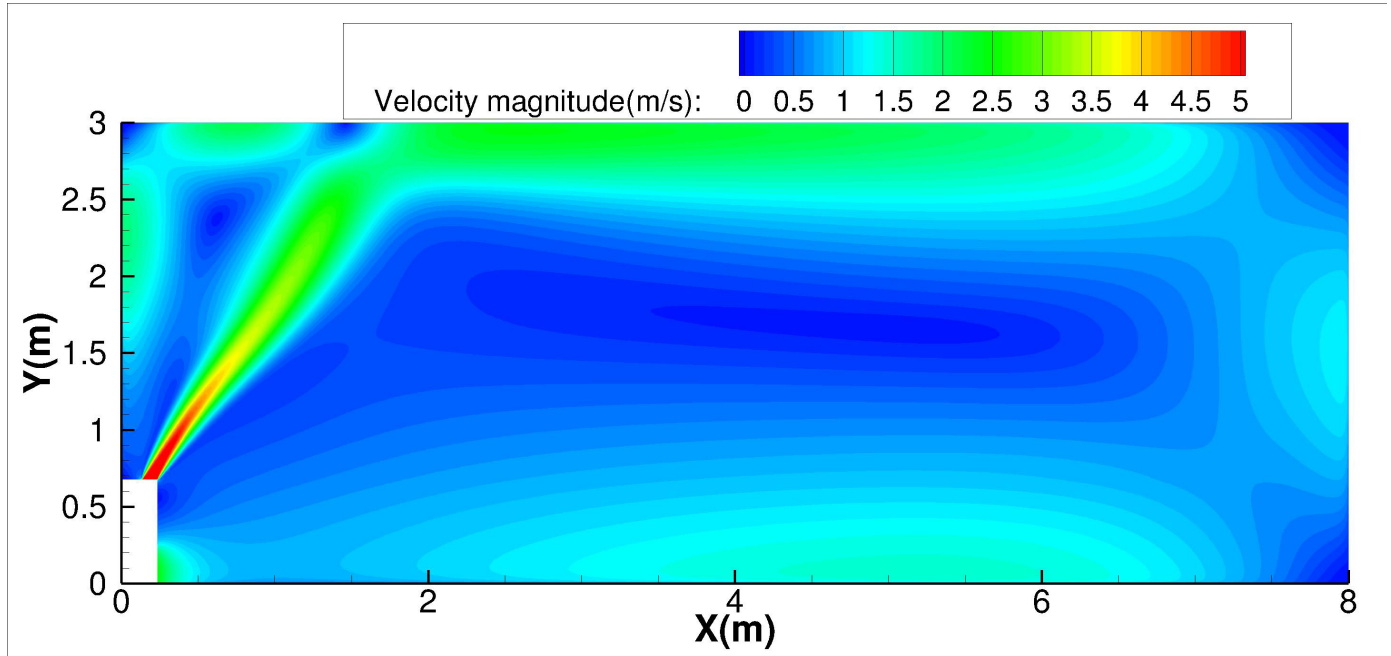

Specifications

Heating temperature distributions

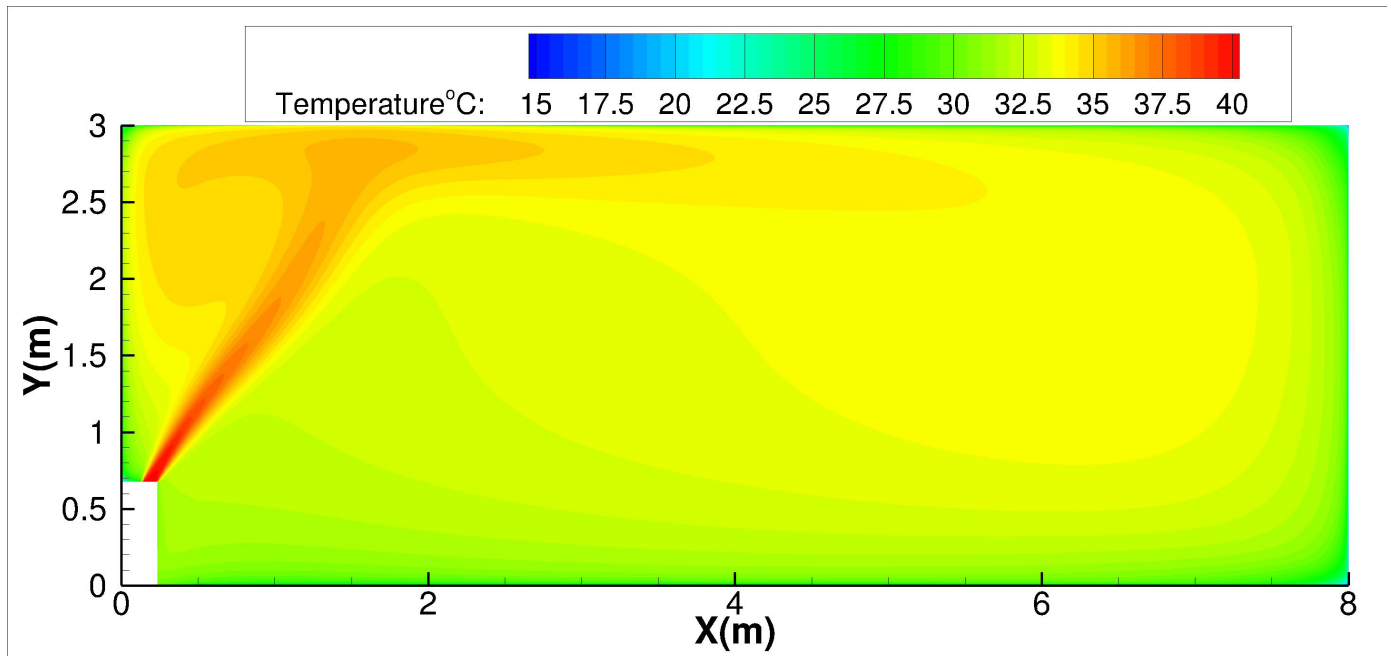

7. Capacity Tables

7.1 Cooling

INDOOR AIRFLOW (CMH)	OUTDOOR DB(°C)	ID WB (°C)	24k															
			16.0				18.0				19.0				22.0			
			ID DB (°C)	23.0	25.0	27.0	29.0	23.0	25.0	27.0	29.0	23.0	25.0	27.0	29.0	23.0	25.0	27.0
853	-15	TC	7.35	7.34	7.34	7.40	7.73	7.88	7.88	7.88	7.93	7.93	7.93	7.93	8.40	8.40	8.40	8.40
		S/T	0.69	0.76	0.84	0.92	0.56	0.63	0.70	0.78	0.49	0.57	0.64	0.71	0.36	0.42	0.49	0.56
		PI	1.53	1.52	1.52	1.53	1.53	1.53	1.53	1.53	1.52	1.52	1.52	1.52	1.52	1.52	1.52	1.52
	-10	TC	7.31	7.30	7.30	7.36	7.69	7.84	7.84	7.84	7.89	7.89	7.89	7.89	8.37	8.37	8.37	8.37
		S/T	0.69	0.77	0.84	0.92	0.56	0.63	0.71	0.79	0.49	0.57	0.64	0.72	0.36	0.43	0.49	0.56
		PI	1.52	1.52	1.52	1.52	1.52	1.52	1.52	1.52	1.51	1.51	1.51	1.51	1.52	1.52	1.52	1.52
	-5	TC	7.26	7.26	7.26	7.32	7.66	7.81	7.81	7.81	7.86	7.86	7.86	7.86	8.35	8.35	8.35	8.35
		S/T	0.69	0.77	0.85	0.93	0.57	0.64	0.71	0.79	0.50	0.58	0.64	0.72	0.36	0.43	0.50	0.57
		PI	1.52	1.51	1.51	1.52	1.52	1.52	1.52	1.52	1.51	1.51	1.51	1.51	1.53	1.53	1.53	1.53
	0	TC	7.23	7.22	7.22	7.28	7.63	7.78	7.78	7.78	7.84	7.84	7.84	7.84	8.34	8.34	8.34	8.34
		S/T	0.70	0.77	0.85	0.93	0.57	0.64	0.72	0.79	0.50	0.58	0.65	0.73	0.36	0.43	0.50	0.57
		PI	1.52	1.52	1.52	1.52	1.53	1.53	1.53	1.53	1.52	1.52	1.52	1.52	1.53	1.53	1.53	1.53
	5	TC	7.19	7.18	7.18	7.24	7.60	7.75	7.75	7.75	7.82	7.82	7.82	7.82	8.34	8.34	8.34	8.34
		S/T	0.70	0.78	0.86	0.94	0.57	0.64	0.72	0.80	0.50	0.58	0.65	0.73	0.36	0.43	0.50	0.57
		PI	1.54	1.53	1.53	1.54	1.54	1.54	1.54	1.54	1.53	1.53	1.53	1.53	1.54	1.54	1.54	1.54
	10	TC	7.15	7.14	7.14	7.20	7.56	7.71	7.71	7.71	7.79	7.79	7.79	7.79	8.31	8.31	8.31	8.31
		S/T	0.70	0.78	0.86	0.94	0.57	0.65	0.72	0.80	0.50	0.58	0.65	0.73	0.37	0.44	0.50	0.57
		PI	1.56	1.56	1.56	1.56	1.56	1.56	1.56	1.56	1.56	1.56	1.56	1.56	1.56	1.56	1.56	1.56
	15	TC	7.09	7.08	7.08	7.14	7.51	7.66	7.66	7.66	7.74	7.74	7.74	7.74	8.28	8.28	8.28	8.28
		S/T	0.71	0.79	0.87	0.95	0.58	0.65	0.73	0.81	0.51	0.59	0.66	0.74	0.37	0.44	0.51	0.58
		PI	1.60	1.60	1.60	1.60	1.60	1.60	1.60	1.60	1.59	1.59	1.59	1.59	1.60	1.60	1.60	1.60
	20	TC	7.01	7.00	7.00	7.06	7.43	7.43	7.43	7.43	7.66	7.66	7.66	7.66	8.21	8.21	8.21	8.21
		S/T	0.71	0.79	0.87	0.95	0.58	0.65	0.73	0.81	0.51	0.59	0.66	0.74	0.37	0.44	0.51	0.58
		PI	1.66	1.65	1.65	1.66	1.65	1.65	1.65	1.65	1.64	1.64	1.64	1.64	1.64	1.64	1.64	1.64
	25	TC	6.69	6.69	6.74	6.80	7.09	7.09	7.09	7.09	7.32	7.32	7.32	7.32	7.86	7.86	7.86	7.86
		S/T	0.72	0.80	0.89	0.97	0.58	0.66	0.74	0.82	0.51	0.59	0.67	0.75	0.36	0.44	0.51	0.58
		PI	1.83	1.83	1.83	1.83	1.82	1.82	1.82	1.82	1.82	1.82	1.82	1.82	1.82	1.83	1.83	1.83
	30	TC	6.37	6.37	6.43	6.49	6.77	6.77	6.77	6.77	6.97	6.97	6.97	6.97	7.52	7.52	7.52	7.52
		S/T	0.73	0.82	0.90	0.99	0.58	0.67	0.75	0.84	0.52	0.60	0.68	0.76	0.36	0.44	0.51	0.59
		PI	2.00	2.00	2.00	2.00	2.01	2.01	2.01	2.01	2.01	2.01	2.01	2.01	2.02	2.02	2.02	2.02
	35	TC	6.06	6.06	6.11	6.17	6.43	6.43	6.43	6.43	6.63	6.63	6.74	6.63	7.17	7.17	7.17	7.17
		S/T	0.74	0.83	0.92	1.00	0.59	0.68	0.76	0.85	0.52	0.60	0.69	0.78	0.36	0.44	0.52	0.60
		PI	2.18	2.18	2.18	2.18	2.19	2.19	2.19	2.19	2.20	2.20	2.20	2.20	2.21	2.21	2.21	2.21
	40	TC	5.71	5.71	5.77	5.83	6.07	6.07	6.07	6.10	6.27	6.27	6.34	6.27	6.78	6.78	6.78	6.78
		S/T	0.76	0.86	0.96	1.00	0.60	0.69	0.79	0.89	0.52	0.62	0.71	0.81	0.35	0.44	0.52	0.61
		PI	2.41	2.41	2.41	2.41	2.42	2.42	2.42	2.42	2.43	2.43	2.43	2.43	2.44	2.44	2.44	2.44
	46	TC	5.29	5.29	5.35	5.40	5.63	5.63	5.63	5.69	5.83	5.83	5.83	5.83	6.29	6.29	6.29	6.29
		S/T	0.77	0.88	0.98	1.00	0.60	0.70	0.81	0.90	0.52	0.62	0.72	0.82	0.35	0.44	0.53	0.62
		PI	2.68	2.68	2.68	2.68	2.69	2.69	2.69	2.69	2.70	2.70	2.70	2.70	2.72	2.72	2.72	2.72
	50	TC	4.94	5.00	5.06	5.12	5.29	5.29	5.29	5.35	5.49	5.49	5.49	5.49	5.95	5.95	5.95	5.95
		S/T	0.79	0.90	1.00	1.00	0.61	0.72	0.83	0.93	0.53	0.63	0.74	0.84	0.34	0.44	0.54	0.63
		PI	2.91	2.91	2.91	2.91	2.92	2.92	2.92	2.92	2.93	2.93	2.93	2.93	2.95	2.95	2.95	2.95

Specifications

1955	-15	TC	11.49	11.61	11.73	11.85	12.08	12.08	12.08	12.20	12.38	12.38	12.38	12.38	13.15	13.15	13.15	13.15
		S/T	0.77	0.88	1.00	1.00	0.60	0.70	0.81	0.98	0.51	0.62	0.72	0.83	0.33	0.42	0.52	0.63
		PI	2.77	2.77	2.77	2.77	2.77	2.77	2.77	2.77	2.76	2.76	2.76	2.76	2.76	2.76	2.76	2.76
	-10	TC	11.42	11.54	11.66	11.78	12.01	12.01	12.01	12.13	12.32	12.32	12.32	12.32	13.11	13.11	13.11	13.11
		S/T	0.78	0.88	1.00	1.00	0.60	0.71	0.82	0.98	0.51	0.62	0.73	0.83	0.33	0.43	0.52	0.63
		PI	2.76	2.76	2.76	2.76	2.76	2.76	2.76	2.76	2.76	2.76	2.76	2.76	2.76	2.76	2.76	2.76
	-5	TC	11.35	11.47	11.59	11.71	11.97	11.97	11.97	12.08	12.28	12.28	12.28	12.28	13.07	13.07	13.07	13.07
		S/T	0.78	0.89	1.00	1.00	0.60	0.71	0.82	0.99	0.52	0.62	0.73	0.84	0.33	0.43	0.53	0.63
		PI	2.76	2.76	2.76	2.76	2.76	2.76	2.76	2.76	2.76	2.76	2.76	2.76	2.77	2.77	2.77	2.77
	0	TC	11.29	11.41	11.53	11.65	11.92	11.92	11.92	12.04	12.24	12.24	12.24	12.24	13.06	13.06	13.06	13.06
		S/T	0.78	0.89	1.00	1.00	0.61	0.72	0.82	0.99	0.52	0.63	0.74	0.84	0.33	0.43	0.53	0.64
		PI	2.77	2.77	2.77	2.77	2.77	2.77	2.77	2.77	2.77	2.77	2.77	2.77	2.78	2.78	2.78	2.78
	5	TC	11.24	11.36	11.47	11.59	11.87	11.87	11.87	11.99	12.20	12.20	12.20	12.20	13.05	13.05	13.05	13.05
		S/T	0.79	0.90	1.00	1.00	0.61	0.72	0.83	1.00	0.52	0.63	0.74	0.85	0.33	0.43	0.53	0.64
		PI	2.79	2.79	2.79	2.79	2.79	2.79	2.79	2.79	2.79	2.79	2.79	2.79	2.80	2.80	2.80	2.80
	10	TC	11.17	11.29	11.40	11.52	11.82	11.82	11.82	11.94	12.15	12.15	12.15	12.15	13.02	13.02	13.02	13.02
		S/T	0.79	0.90	1.00	1.00	0.61	0.72	0.83	1.00	0.52	0.63	0.74	0.85	0.34	0.44	0.53	0.64
		PI	2.84	2.84	2.84	2.84	2.83	2.83	2.83	2.83	2.83	2.83	2.83	2.83	2.83	2.83	2.83	2.83
	15	TC	11.08	11.19	11.31	11.43	11.74	11.74	11.74	11.86	12.08	12.08	12.08	12.08	12.96	12.96	12.96	12.96
		S/T	0.80	0.91	1.00	1.00	0.62	0.73	0.84	0.95	0.53	0.64	0.75	0.86	0.34	0.44	0.54	0.65
		PI	2.91	2.91	2.91	2.91	2.90	2.90	2.90	2.90	2.89	2.89	2.89	2.89	2.89	2.89	2.89	2.89
	20	TC	10.95	11.07	11.18	11.30	11.61	11.61	11.61	11.73	11.96	11.96	11.96	11.96	12.85	12.85	12.85	12.85
		S/T	0.80	0.91	1.00	1.00	0.62	0.73	0.84	0.95	0.53	0.64	0.75	0.86	0.34	0.44	0.54	0.65
		PI	3.01	3.01	3.01	3.01	3.00	3.00	3.00	3.00	2.99	2.99	2.99	2.99	2.98	2.98	2.98	2.98
	25	TC	10.46	10.58	10.69	10.81	11.10	11.10	11.10	11.21	11.44	11.44	11.44	11.44	12.30	12.30	12.30	12.30
		S/T	0.81	0.93	1.00	1.00	0.63	0.74	0.86	0.98	0.54	0.65	0.77	0.88	0.34	0.44	0.55	0.66
		PI	3.31	3.31	3.31	3.31	3.31	3.31	3.31	3.31	3.31	3.31	3.31	3.31	3.31	3.31	3.31	3.31
	30	TC	9.98	10.06	10.18	10.29	10.61	10.61	10.61	10.72	10.92	10.92	10.92	11.04	11.76	11.76	11.76	11.76
		S/T	0.83	0.96	1.00	1.00	0.63	0.76	0.88	1.00	0.54	0.66	0.78	0.90	0.33	0.45	0.56	0.67
		PI	3.63	3.63	3.63	3.63	3.64	3.64	3.64	3.64	3.65	3.65	3.65	3.65	3.66	3.66	3.66	3.66
	35	TC	9.46	9.54	9.63	9.72	10.06	10.06	10.18	10.29	10.38	10.38	10.55	10.67	11.21	11.21	11.21	11.21
		S/T	0.85	0.98	1.00	1.00	0.64	0.77	0.90	1.00	0.55	0.67	0.80	0.91	0.33	0.45	0.57	0.68
		PI	3.97	3.97	3.97	3.97	3.99	3.99	3.99	3.99	3.99	3.99	4.00	3.99	4.02	4.02	4.02	4.02
	40	TC	8.91	9.00	9.08	9.17	9.49	9.49	9.59	9.69	9.79	9.79	9.89	9.99	10.60	10.60	10.60	10.60
		S/T	0.89	1.00	1.00	1.00	0.66	0.81	0.94	1.00	0.56	0.70	0.84	0.97	0.33	0.45	0.58	0.90
		PI	4.38	4.38	4.38	4.38	4.40	4.40	4.40	4.40	4.41	4.41	4.41	4.41	4.44	4.44	4.44	4.44
	46	TC	8.25	8.34	8.43	8.51	8.80	8.80	8.89	8.97	9.09	9.09	9.09	9.17	9.86	9.86	9.86	9.86
		S/T	0.90	1.00	1.00	1.00	0.67	0.82	0.97	1.00	0.57	0.71	0.85	0.99	0.32	0.46	0.59	0.92
		PI	4.87	4.87	4.87	4.87	4.89	4.89	4.89	4.89	4.91	4.91	4.91	4.91	4.95	4.95	4.95	4.95
	50	TC	7.74	7.82	7.91	7.99	8.28	8.28	8.37	8.45	8.57	8.57	8.57	8.66	9.29	9.29	9.29	9.29
		S/T	0.93	1.00	1.00	1.00	0.69	0.85	1.00	1.00	0.57	0.73	0.88	1.00	0.32	0.46	0.60	0.97
		PI	5.27	5.27	5.27	5.27	5.30	5.30	5.30	5.30	5.31	5.31	5.31	5.31	5.35	5.35	5.35	5.35

TC:Total Cooling Capacity (kW)

S/T:Sensible Cooling Capacity Ratio

PI:Power Input(kW)

Note: The table shows the case where the operation frequency of a compressor is fixed.

2300	-15	TC	15.33	15.33	15.48	15.63	16.12	16.12	16.12	16.27	16.53	16.53	16.53	16.53	17.54	17.54	17.54	17.54
		S/T	0.73	0.84	1.00	1.00	0.58	0.68	0.77	0.98	0.50	0.60	0.70	0.78	0.34	0.42	0.51	0.60
		PI	3.95	3.95	3.95	3.95	3.94	3.94	3.94	3.94	3.94	3.94	3.94	3.94	3.94	3.93	3.93	3.93
	-10	TC	15.23	15.23	15.38	15.53	16.03	16.03	16.03	16.18	16.45	16.45	16.45	16.45	17.48	17.48	17.48	17.48
		S/T	0.74	0.84	1.00	1.00	0.58	0.68	0.78	0.98	0.50	0.60	0.70	0.79	0.34	0.43	0.51	0.60
		PI	3.93	3.93	3.93	3.93	3.93	3.93	3.93	3.93	3.93	3.93	3.93	3.93	3.94	3.94	3.94	3.94
	-5	TC	15.14	15.14	15.29	15.44	15.97	15.97	15.97	16.12	16.38	16.38	16.38	16.38	17.44	17.44	17.44	17.44
		S/T	0.74	0.85	1.00	1.00	0.59	0.68	0.78	0.99	0.51	0.60	0.70	0.79	0.34	0.43	0.52	0.60
		PI	3.93	3.93	3.93	3.93	3.92	3.92	3.92	3.92	3.93	3.93	3.93	3.93	3.94	3.94	3.94	3.94
	0	TC	15.07	15.07	15.22	15.36	15.91	15.91	15.91	16.06	16.34	16.34	16.34	16.34	17.42	17.42	17.42	17.42
		S/T	0.74	0.85	1.00	1.00	0.59	0.69	0.78	0.99	0.51	0.61	0.71	0.79	0.34	0.43	0.52	0.61
		PI	3.94	3.94	3.94	3.94	3.94	3.94	3.94	3.94	3.95	3.95	3.95	3.95	3.96	3.96	3.96	3.96
	5	TC	14.99	14.99	15.14	15.29	15.85	15.85	15.85	16.00	16.29	16.29	16.29	16.29	17.41	17.41	17.41	17.41
		S/T	0.75	0.86	1.00	1.00	0.59	0.69	0.79	1.00	0.51	0.61	0.71	0.80	0.34	0.43	0.52	0.61
		PI	3.98	3.98	3.98	3.98	3.97	3.97	3.97	3.97	3.98	3.98	3.98	3.98	3.99	3.99	3.99	3.99
	10	TC	14.90	14.90	15.05	15.19	15.78	15.78	15.78	15.92	16.22	16.22	16.22	16.22	17.36	17.36	17.36	17.36
		S/T	0.75	0.86	1.00	1.00	0.59	0.69	0.79	1.00	0.51	0.61	0.71	0.80	0.35	0.44	0.52	0.61
		PI	4.04	4.04	4.04	4.04	4.03	4.03	4.03	4.03	4.04	4.04	4.04	4.04	4.04	4.04	4.04	4.04
	15	TC	14.78	14.78	14.93	15.07	15.67	15.67	15.67	15.81	16.12	16.12	16.12	16.12	17.29	17.29	17.29	17.29
		S/T	0.76	0.87	0.97	1.00	0.60	0.70	0.80	0.89	0.52	0.62	0.72	0.81	0.35	0.44	0.53	0.62
		PI	4.14	4.14	4.14	4.14	4.13	4.13	4.13	4.13	4.13	4.13	4.13	4.13	4.12	4.12	4.12	4.12
20	TC	14.61	14.61	14.76	14.90	15.50	15.50	15.50	15.65	15.96	15.96	15.96	15.96	17.14	17.14	17.14	17.14	
	S/T	0.76	0.87	0.97	1.00	0.60	0.70	0.80	0.89	0.52	0.62	0.72	0.81	0.35	0.44	0.53	0.62	
	PI	4.29	4.29	4.29	4.29	4.27	4.27	4.27	4.27	4.27	4.27	4.27	4.27	4.25	4.25	4.25	4.25	
25	TC	13.95	14.10	14.24	14.38	14.81	14.81	14.81	14.96	15.25	15.25	15.25	15.25	16.42	16.42	16.42	16.42	
	S/T	0.78	0.88	0.99	1.00	0.61	0.71	0.81	0.91	0.53	0.63	0.73	0.83	0.35	0.44	0.53	0.63	
	PI	4.73	4.73	4.73	4.73	4.73	4.73	4.73	4.73	4.72	4.72	4.72	4.72	4.73	4.73	4.73	4.73	
30	TC	13.29	13.44	13.58	13.72	14.13	14.13	14.13	14.27	14.56	14.56	14.56	14.56	15.68	15.68	15.68	15.68	
	S/T	0.79	0.90	1.00	1.00	0.61	0.72	0.83	0.94	0.53	0.64	0.74	0.85	0.34	0.44	0.54	0.64	
	PI	5.18	5.18	5.18	5.18	5.19	5.19	5.19	5.19	5.19	5.19	5.19	5.19	5.22	5.22	5.22	5.22	
35	TC	12.63	12.75	12.86	12.98	13.44	13.44	13.44	13.58	13.87	13.87	14.07	13.87	14.96	14.96	14.96	14.96	
	S/T	0.80	0.92	1.00	1.00	0.62	0.73	0.85	0.96	0.53	0.65	0.75	0.87	0.34	0.44	0.55	0.65	
	PI	5.66	5.66	5.66	5.66	5.68	5.68	5.68	5.68	5.69	5.69	5.70	5.69	5.73	5.73	5.73	5.73	
40	TC	11.91	12.02	12.14	12.25	12.69	12.69	12.74	12.87	13.09	13.09	13.20	13.14	14.15	14.15	14.15	14.15	
	S/T	0.84	0.97	1.00	1.00	0.64	0.76	0.88	1.00	0.54	0.67	0.79	0.91	0.33	0.45	0.56	0.90	
	PI	6.25	6.25	6.25	6.25	6.27	6.27	6.27	6.27	6.29	6.29	6.29	6.29	6.34	6.34	6.34	6.34	
46	TC	11.01	11.13	11.24	11.36	11.76	11.76	11.88	11.99	12.14	12.14	12.14	12.14	12.25	13.14	13.14	13.14	13.14
	S/T	0.85	0.99	1.00	1.00	0.64	0.78	0.90	1.00	0.55	0.68	0.80	0.93	0.33	0.45	0.57	0.92	
	PI	6.95	6.95	6.95	6.95	6.98	6.98	6.98	6.98	7.00	7.00	7.00	7.00	7.06	7.06	7.06	7.06	
50	TC	10.35	10.47	10.58	10.70	11.07	11.07	11.19	11.30	11.42	11.42	11.42	11.53	12.39	12.39	12.39	12.39	
	S/T	0.88	1.00	1.00	1.00	0.66	0.80	0.93	1.00	0.56	0.69	0.83	0.96	0.33	0.45	0.58	0.97	
	PI	7.53	7.53	7.53	7.53	7.56	7.56	7.56	7.56	7.58	7.58	7.58	7.58	7.64	7.64	7.64	7.64	

TC:Total Cooling Capacity (kW)

S/T:Sensible Cooling Capacity Ratio

PI:Power Input(kW)

Note: The table shows the case where the operation frequency of a compressor is fixed.

2340	-15	TC	17.57	17.57	17.75	17.93	18.47	18.47	18.47	18.47	18.92	18.92	18.92	18.92	20.11	20.11	20.11	20.11
		S/T	0.71	0.80	1.00	1.00	0.57	0.65	0.73	0.98	0.50	0.58	0.67	0.74	0.35	0.42	0.50	0.58
		PI	4.65	4.65	4.65	4.65	4.63	4.63	4.63	4.63	4.63	4.63	4.63	4.63	4.62	4.62	4.62	4.62
	-10	TC	17.46	17.46	17.64	17.82	18.36	18.36	18.36	18.36	18.83	18.83	18.83	18.83	20.05	20.05	20.05	20.05
		S/T	0.72	0.81	1.00	1.00	0.57	0.65	0.74	0.98	0.50	0.58	0.67	0.75	0.35	0.43	0.50	0.58
		PI	4.62	4.62	4.62	4.62	4.62	4.62	4.62	4.62	4.62	4.62	4.62	4.62	4.63	4.63	4.63	4.63
	-5	TC	17.36	17.36	17.54	17.72	18.29	18.29	18.29	18.29	18.76	18.76	18.76	18.76	19.99	19.99	19.99	19.99
		S/T	0.72	0.81	1.00	1.00	0.58	0.65	0.74	0.99	0.51	0.59	0.67	0.75	0.35	0.43	0.51	0.59
		PI	4.62	4.62	4.62	4.62	4.62	4.62	4.62	4.62	4.62	4.62	4.62	4.62	4.63	4.63	4.63	4.63
	0	TC	17.27	17.27	17.45	17.63	18.22	18.22	18.22	18.22	18.71	18.71	18.71	18.71	19.98	19.98	19.98	19.98
		S/T	0.73	0.81	1.00	1.00	0.58	0.66	0.74	0.99	0.51	0.59	0.68	0.75	0.35	0.43	0.51	0.59
		PI	4.64	4.64	4.64	4.64	4.63	4.63	4.63	4.63	4.64	4.64	4.64	4.64	4.65	4.65	4.65	4.65
	5	TC	17.19	17.19	17.36	17.54	18.16	18.16	18.16	18.16	18.65	18.65	18.65	18.65	19.96	19.96	19.96	19.96
		S/T	0.73	0.82	1.00	1.00	0.58	0.66	0.75	1.00	0.51	0.59	0.68	0.76	0.35	0.43	0.51	0.59
		PI	4.68	4.68	4.68	4.68	4.67	4.67	4.67	4.67	4.68	4.68	4.68	4.68	4.69	4.69	4.69	4.69
	10	TC	17.08	17.08	17.26	17.43	18.07	18.07	18.07	18.07	18.57	18.57	18.57	18.57	19.91	19.91	19.91	19.91
		S/T	0.73	0.82	1.00	1.00	0.58	0.66	0.75	1.00	0.51	0.59	0.68	0.76	0.36	0.44	0.51	0.59
		PI	4.76	4.76	4.76	4.76	4.75	4.75	4.75	4.75	4.75	4.75	4.75	4.75	4.75	4.75	4.75	4.75
	15	TC	16.94	16.94	17.12	17.29	17.95	17.95	17.95	17.95	18.46	18.46	18.46	18.46	19.82	19.82	19.82	19.82
		S/T	0.74	0.83	0.92	1.00	0.59	0.67	0.76	0.85	0.52	0.60	0.69	0.77	0.36	0.44	0.52	0.60
		PI	4.87	4.87	4.87	4.87	4.86	4.86	4.86	4.86	4.85	4.85	4.85	4.85	4.85	4.85	4.85	4.85
	20	TC	16.75	16.75	16.92	17.10	17.76	17.76	17.76	17.76	18.27	18.27	18.27	18.27	19.65	19.65	19.65	19.65
		S/T	0.74	0.83	0.92	1.00	0.59	0.67	0.76	0.85	0.52	0.60	0.69	0.77	0.36	0.44	0.52	0.60
		PI	5.04	5.04	5.04	5.04	5.02	5.02	5.02	5.02	5.01	5.01	5.01	5.01	4.99	4.99	4.99	4.99
	25	TC	15.98	15.98	16.15	16.32	16.98	16.98	16.98	16.98	17.47	17.47	17.47	17.47	18.79	18.79	18.79	18.79
		S/T	0.75	0.84	0.94	1.00	0.59	0.68	0.78	0.87	0.52	0.61	0.70	0.79	0.35	0.44	0.52	0.60
		PI	5.55	5.55	5.55	5.55	5.55	5.55	5.55	5.55	5.55	5.55	5.55	5.55	5.55	5.55	5.55	5.55
	30	TC	15.23	15.23	15.37	15.52	16.18	16.18	16.18	16.35	16.69	16.69	16.69	16.69	17.99	17.99	17.99	17.99
		S/T	0.76	0.86	0.96	1.00	0.60	0.69	0.79	0.88	0.52	0.62	0.71	0.80	0.35	0.44	0.52	0.61
		PI	6.08	6.08	6.08	6.08	6.09	6.09	6.09	6.09	6.10	6.10	6.10	6.10	6.13	6.13	6.13	6.13
	35	TC	14.45	14.45	14.60	14.74	15.40	15.40	15.40	15.54	15.86	15.86	16.12	15.86	17.13	17.13	17.13	17.13
		S/T	0.77	0.88	0.98	1.00	0.60	0.70	0.81	0.90	0.53	0.62	0.72	0.82	0.35	0.44	0.53	0.62
		PI	6.65	6.65	6.65	6.65	6.68	6.68	6.68	6.68	6.69	6.69	6.70	6.69	6.73	6.73	6.73	6.73
	40	TC	13.60	13.65	13.79	13.92	14.50	14.50	14.50	14.64	14.96	14.96	15.10	14.96	16.17	16.17	16.17	16.17
		S/T	0.80	0.91	1.00	1.00	0.62	0.73	0.84	0.95	0.53	0.64	0.75	0.86	0.34	0.44	0.54	0.62
		PI	7.34	7.34	7.34	7.34	7.37	7.37	7.37	7.37	7.39	7.39	7.39	7.39	7.44	7.44	7.44	7.44
	46	TC	12.60	12.72	12.83	12.94	13.43	13.43	13.43	13.58	13.89	13.89	13.89	13.89	15.04	15.04	15.04	15.04
		S/T	0.81	0.93	1.00	1.00	0.62	0.74	0.86	0.97	0.54	0.65	0.76	0.88	0.34	0.44	0.55	0.62
		PI	8.16	8.16	8.16	8.16	8.20	8.20	8.20	8.20	8.22	8.22	8.22	8.22	8.29	8.29	8.29	8.29
	50	TC	11.83	11.94	12.06	12.17	12.63	12.63	12.63	12.74	13.06	13.06	13.06	13.20	14.15	14.15	14.15	14.15
		S/T	0.83	0.96	1.00	1.00	0.63	0.76	0.88	1.00	0.54	0.66	0.78	0.90	0.33	0.45	0.56	0.62
		PI	8.84	8.84	8.84	8.84	8.88	8.88	8.88	8.88	8.91	8.91	8.91	8.91	8.98	8.98	8.98	8.98

TC:Total Cooling Capacity (kW)

S/T:Sensible Cooling Capacity Ratio

PI:Power Input(kW)

Note: The table shows the case where the operation frequency of a compressor is fixed.

7.2 Heating

24k								[SI_Unit]	
INDOOR AIRFLOW (CMH)	HEATING PERFORMANCE AT INDOOR DRY BULB TEMPERATURE								
	OUTDOOR DB(°C)	TC:TOTAL CAPACITY IN KILOWATTS (KW)				PI:TOTAL POWER IN KILOWATTS (KW)			
		Indoor Conditions (DB °C)				Indoor Conditions (DB °C)			
		16.0	20.0	22.0	24.0	16.0	20.0	22.0	24.0
853	-15.0	4.42	4.37	4.34	4.32	1.20	1.22	1.29	1.31
	-10.0	4.71	4.66	4.64	4.61	1.28	1.31	1.37	1.40
	-7.0	4.94	4.88	4.86	4.83	1.36	1.39	1.46	1.49
	-5.6	5.23	5.17	5.15	5.12	1.40	1.47	1.50	1.53
	-2.8	5.52	5.44	5.41	5.38	1.49	1.56	1.60	1.63
	0.0	5.73	5.64	5.61	5.58	1.58	1.65	1.69	1.73
	2.8	6.16	6.08	6.05	5.99	1.68	1.77	1.80	1.84
	5.6	6.80	6.72	6.69	6.63	1.78	1.87	1.91	1.96
	7.0	7.48	7.39	7.16	7.13	1.85	2.01	1.98	2.02
	11.1	7.94	7.85	7.79	7.74	1.99	2.08	2.13	2.17
	13.9	8.37	8.26	8.20	8.14	2.08	2.18	2.23	2.28
	16.7	8.81	8.69	8.63	8.58	2.18	2.29	2.34	2.39
18.0	9.01	8.90	8.84	8.75	2.23	2.34	2.39	2.44	
1023	-15.0	4.51	4.46	4.44	4.41	1.21	1.24	1.29	1.33
	-10.0	4.81	4.76	4.74	4.71	1.29	1.32	1.38	1.42
	-7.0	5.04	4.99	4.96	4.93	1.37	1.41	1.47	1.51
	-5.6	5.35	5.29	5.26	5.23	1.42	1.48	1.52	1.55
	-2.8	5.64	5.55	5.52	5.49	1.51	1.58	1.62	1.65
	0.0	5.84	5.76	5.73	5.70	1.60	1.67	1.71	1.75
	2.8	6.28	6.19	6.16	6.10	1.71	1.78	1.82	1.86
	5.6	6.95	6.86	6.80	6.77	1.81	1.89	1.94	1.98
	7.0	7.63	7.53	7.30	7.27	1.87	2.03	2.00	2.05
	11.1	8.08	8.00	7.94	7.88	2.02	2.10	2.15	2.20
	13.9	8.52	8.43	8.37	8.32	2.11	2.21	2.26	2.31
	16.7	8.98	8.84	8.78	8.72	2.21	2.31	2.37	2.42
18.0	9.18	9.04	8.98	8.92	2.26	2.36	2.42	2.47	
1192	-15.0	4.57	4.50	4.47	4.45	1.22	1.25	1.31	1.34
	-10.0	4.88	4.80	4.77	4.75	1.31	1.33	1.40	1.43
	-7.0	5.11	5.03	5.00	4.97	1.39	1.42	1.49	1.52
	-5.6	5.41	5.32	5.29	5.26	1.43	1.50	1.53	1.57
	-2.8	5.70	5.61	5.58	5.55	1.52	1.60	1.63	1.67
	0.0	5.90	5.81	5.79	5.76	1.61	1.69	1.73	1.77
	2.8	6.34	6.25	6.22	6.16	1.72	1.80	1.84	1.88
	5.6	7.04	6.92	6.89	6.83	1.83	1.92	1.96	2.01
	7.0	7.75	7.62	7.39	7.33	1.89	2.06	2.03	2.06
	11.1	8.20	8.08	8.03	7.97	2.04	2.13	2.18	2.23
	13.9	8.63	8.52	8.46	8.40	2.13	2.24	2.29	2.34
	16.7	9.07	8.95	8.90	8.84	2.24	2.34	2.40	2.45
18.0	9.30	9.16	9.10	9.04	2.29	2.40	2.45	2.51	

Note: The table shows the case where the operation frequency of a compressor is fixed.

36k								[SI_Unit]	
INDOOR AIRFLOW (CMH)	HEATING PERFORMANCE AT INDOOR DRY BULB TEMPERATURE								
	OUTDOOR DB(°C)	TC:TOTAL CAPACITY IN KILOWATTS (KW)				PI:TOTAL POWER IN KILOWATTS (KW)			
		Indoor Conditions (DB °C)				Indoor Conditions (DB °C)			
		16.0	20.0	22.0	24.0	16.0	20.0	22.0	24.0
1504	-15.0	6.81	6.71	6.69	6.64	1.90	1.94	2.03	2.08
	-10.0	7.27	7.16	7.14	7.09	2.03	2.07	2.17	2.22
	-7.0	7.62	7.51	7.48	7.42	2.15	2.20	2.30	2.36
	-5.6	8.06	7.94	7.91	7.85	2.21	2.32	2.37	2.43
	-2.8	8.46	8.37	8.32	8.26	2.35	2.47	2.53	2.58
	0.0	8.78	8.66	8.61	8.55	2.49	2.62	2.68	2.74
	2.8	9.45	9.30	9.24	9.19	2.67	2.80	2.86	2.93
	5.6	10.43	10.29	10.23	10.17	2.84	2.98	3.05	3.12
	7.0	11.54	11.38	11.03	10.97	2.93	3.19	3.14	3.21
	11.1	12.22	12.07	11.98	11.90	3.16	3.31	3.39	3.47
	13.9	12.88	12.71	12.62	12.54	3.32	3.48	3.56	3.64
	16.7	13.55	13.35	13.26	13.17	3.48	3.64	3.73	3.80
18.0	13.84	13.67	13.58	13.46	3.55	3.72	3.80	3.88	
1728	-15.0	6.91	6.84	6.79	6.74	1.92	1.96	2.06	2.10
	-10.0	7.38	7.30	7.25	7.20	2.05	2.09	2.19	2.24
	-7.0	7.73	7.65	7.60	7.54	2.17	2.23	2.33	2.38
	-5.6	8.20	8.11	8.06	8.00	2.23	2.34	2.40	2.45
	-2.8	8.64	8.52	8.46	8.43	2.38	2.49	2.55	2.61
	0.0	8.95	8.84	8.78	8.72	2.52	2.64	2.71	2.77
	2.8	9.62	9.51	9.45	9.36	2.69	2.83	2.89	2.96
	5.6	10.66	10.52	10.43	10.37	2.87	3.01	3.08	3.15
	7.0	11.77	11.61	11.26	11.17	2.96	3.22	3.17	3.24
	11.1	12.48	12.30	12.22	12.16	3.19	3.35	3.42	3.50
	13.9	13.15	12.97	12.88	12.80	3.35	3.51	3.59	3.67
	16.7	13.81	13.64	13.55	13.44	3.51	3.68	3.76	3.84
18.0	14.13	13.96	13.84	13.75	3.58	3.76	3.83	3.92	
1955	-15.0	6.99	6.92	6.87	6.82	1.93	1.98	2.07	2.12
	-10.0	7.46	7.39	7.33	7.28	2.06	2.11	2.21	2.26
	-7.0	7.82	7.74	7.68	7.63	2.19	2.24	2.35	2.40
	-5.6	8.29	8.20	8.14	8.09	2.25	2.36	2.42	2.47
	-2.8	8.72	8.64	8.58	8.52	2.40	2.51	2.57	2.63
	0.0	9.07	8.93	8.87	8.81	2.54	2.67	2.73	2.79
	2.8	9.74	9.59	9.53	9.48	2.72	2.85	2.92	2.98
	5.6	10.75	10.61	10.55	10.46	2.89	3.03	3.10	3.18
	7.0	11.88	11.72	11.38	11.29	2.98	3.25	3.20	3.27
	11.1	12.59	12.42	12.36	12.27	3.22	3.38	3.45	3.53
	13.9	13.26	13.09	13.00	12.91	3.38	3.54	3.63	3.71
	16.7	13.96	13.75	13.67	13.58	3.54	3.71	3.79	3.87
18.0	14.28	14.07	13.99	13.90	3.62	3.79	3.87	3.96	

Note: The table shows the case where the operation frequency of a compressor is fixed.

48k								[SI_Unit]	
INDOOR AIRFLOW (CMH)	HEATING PERFORMANCE AT INDOOR DRY BULB TEMPERATURE								
	OUTDOOR DB(°C)	TC:TOTAL CAPACITY IN KILOWATTS (KW)				PI:TOTAL POWER IN KILOWATTS (KW)			
		Indoor Conditions (DB °C)				Indoor Conditions (DB °C)			
		16.0	20.0	22.0	24.0	16.0	20.0	22.0	24.0
2000	-15.0	9.03	8.91	8.86	8.81	2.97	3.04	3.18	3.25
	-10.0	9.64	9.51	9.46	9.40	3.17	3.25	3.40	3.47
	-7.0	10.10	9.96	9.91	9.85	3.37	3.45	3.61	3.69
	-5.6	10.69	10.54	10.48	10.43	3.47	3.64	3.72	3.81
	-2.8	11.24	11.09	11.04	10.95	3.69	3.87	3.96	4.04
	0.0	11.68	11.50	11.41	11.36	3.91	4.10	4.19	4.29
	2.8	12.55	12.37	12.29	12.20	4.17	4.38	4.48	4.58
	5.6	13.85	13.68	13.56	13.48	4.45	4.66	4.77	4.88
	7.0	15.26	15.07	14.60	14.52	4.59	5.00	4.92	5.04
	11.1	16.20	15.97	15.88	15.77	4.96	5.20	5.31	5.43
	13.9	17.07	16.84	16.72	16.61	5.20	5.45	5.58	5.69
16.7	17.94	17.68	17.57	17.45	5.45	5.70	5.83	5.96	
18.0	18.35	18.09	17.97	17.86	5.57	5.83	5.96	6.09	
2170	-15.0	9.18	9.08	9.01	8.96	3.00	3.08	3.22	3.30
	-10.0	9.80	9.70	9.62	9.57	3.20	3.28	3.43	3.52
	-7.0	10.27	10.16	10.08	10.02	3.40	3.49	3.65	3.74
	-5.6	10.89	10.77	10.69	10.63	3.51	3.68	3.77	3.85
	-2.8	11.47	11.33	11.27	11.18	3.73	3.91	4.00	4.09
	0.0	11.91	11.73	11.68	11.59	3.95	4.14	4.24	4.33
	2.8	12.81	12.63	12.52	12.43	4.22	4.42	4.53	4.63
	5.6	14.14	13.97	13.85	13.77	4.49	4.71	4.82	4.93
	7.0	15.58	15.39	14.92	14.84	4.64	5.05	4.97	5.09
	11.1	16.55	16.32	16.20	16.11	5.00	5.25	5.37	5.49
	13.9	17.42	17.19	17.07	16.96	5.25	5.51	5.62	5.75
16.7	18.32	18.06	17.94	17.83	5.50	5.76	5.89	6.02	
18.0	18.76	18.49	18.38	18.23	5.61	5.88	6.02	6.15	
2300	-15.0	9.29	9.16	9.12	9.04	3.03	3.11	3.25	3.32
	-10.0	9.92	9.79	9.73	9.66	3.23	3.31	3.47	3.55
	-7.0	10.39	10.25	10.20	10.11	3.43	3.52	3.69	3.77
	-5.6	11.01	10.86	10.80	10.72	3.54	3.71	3.80	3.89
	-2.8	11.59	11.44	11.36	11.30	3.76	3.95	4.03	4.13
	0.0	12.02	11.85	11.76	11.68	3.98	4.18	4.28	4.38
	2.8	12.92	12.75	12.66	12.55	4.26	4.47	4.57	4.68
	5.6	14.29	14.09	14.00	13.91	4.54	4.76	4.87	4.98
	7.0	15.76	15.53	15.07	14.95	4.68	5.10	5.02	5.14
	11.1	16.69	16.46	16.38	16.26	5.05	5.30	5.42	5.54
	13.9	17.59	17.36	17.25	17.13	5.31	5.56	5.68	5.81
16.7	18.49	18.23	18.12	18.00	5.56	5.82	5.95	6.08	
18.0	18.93	18.67	18.55	18.41	5.67	5.94	6.08	6.22	

Note: The table shows the case where the operation frequency of a compressor is fixed.

55k								[SI_Unit]	
INDOOR AIRFLOW (CMH)	HEATING PERFORMANCE AT INDOOR DRY BULB TEMPERATURE								
	OUTDOOR DB(°C)	TC:TOTAL CAPACITY IN KILOWATTS (KW)				PI:TOTAL POWER IN KILOWATTS (KW)			
		Indoor Conditions (DB °C)				Indoor Conditions (DB °C)			
		16.0	20.0	22.0	24.0	16.0	20.0	22.0	24.0
2020	-15.0	10.36	10.24	10.19	10.11	3.32	3.40	3.56	3.64
	-10.0	11.06	10.93	10.88	10.80	3.54	3.63	3.79	3.88
	-7.0	11.59	11.45	11.40	11.31	3.76	3.85	4.03	4.12
	-5.6	12.26	12.12	12.06	11.97	3.87	4.06	4.16	4.25
	-2.8	12.93	12.76	12.67	12.61	4.12	4.32	4.42	4.52
	0.0	13.42	13.22	13.13	13.05	4.36	4.58	4.69	4.79
	2.8	14.41	14.21	14.12	14.03	4.67	4.89	5.00	5.12
	5.6	15.95	15.71	15.63	15.51	4.96	5.20	5.32	5.44
	7.0	17.61	17.36	16.83	16.72	5.13	5.58	5.50	5.62
	11.1	18.66	18.40	18.28	18.17	5.53	5.80	5.93	6.06
	13.9	19.65	19.39	19.27	19.13	5.81	6.09	6.22	6.36
	16.7	20.66	20.37	20.23	20.11	6.08	6.36	6.51	6.66
18.0	21.13	20.84	20.72	20.58	6.20	6.50	6.65	6.80	
2180	-15.0	10.58	10.43	10.39	10.31	3.36	3.44	3.60	3.68
	-10.0	11.30	11.14	11.09	11.01	3.58	3.67	3.84	3.93
	-7.0	11.84	11.67	11.62	11.53	3.80	3.90	4.08	4.17
	-5.6	12.52	12.35	12.29	12.21	3.91	4.11	4.20	4.30
	-2.8	13.19	13.02	12.93	12.84	4.16	4.37	4.47	4.57
	0.0	13.68	13.48	13.39	13.31	4.41	4.63	4.74	4.84
	2.8	14.70	14.50	14.41	14.29	4.72	4.94	5.06	5.17
	5.6	16.26	16.03	15.92	15.83	5.02	5.26	5.38	5.50
	7.0	17.96	17.70	17.18	17.07	5.19	5.64	5.55	5.68
	11.1	19.04	18.78	18.66	18.52	5.59	5.86	5.99	6.13
	13.9	20.05	19.79	19.65	19.50	5.87	6.15	6.28	6.42
	16.7	21.07	20.78	20.66	20.52	6.15	6.43	6.58	6.73
18.0	21.56	21.27	21.13	20.98	6.27	6.57	6.72	6.87	
2340	-15.0	10.67	10.55	10.47	10.43	3.38	3.47	3.63	3.72
	-10.0	11.39	11.26	11.18	11.13	3.61	3.70	3.87	3.96
	-7.0	11.94	11.80	11.72	11.66	3.83	3.93	4.11	4.21
	-5.6	12.64	12.50	12.41	12.35	3.95	4.15	4.24	4.34
	-2.8	13.34	13.16	13.08	12.99	4.20	4.41	4.52	4.62
	0.0	13.83	13.63	13.54	13.45	4.46	4.68	4.78	4.89
	2.8	14.84	14.64	14.55	14.44	4.77	4.99	5.11	5.22
	5.6	16.41	16.21	16.09	15.97	5.07	5.31	5.44	5.56
	7.0	18.10	17.88	17.36	17.24	5.23	5.70	5.61	5.74
	11.1	19.21	18.95	18.84	18.72	5.65	5.92	6.06	6.19
	13.9	20.26	19.97	19.85	19.71	5.93	6.21	6.35	6.49
	16.7	21.27	20.98	20.84	20.69	6.20	6.50	6.65	6.80
18.0	21.77	21.48	21.33	21.19	6.34	6.64	6.80	6.95	

Note: The table shows the case where the operation frequency of a compressor is fixed.

8. Capacity Correction Factor for Height Difference

Capacity(Btu/h)	24k		Pipe Length (m)			
Cooling			5	10	15	25
Height difference H (m)	Indoor Upper than Outdoor	15			0.938	0.901
		10		0.966	0.948	0.910
		5	0.995	0.976	0.957	0.919
		0	1.000	0.981	0.962	0.924
	Outdoor Upper than Indoor	-5	1.000	0.981	0.962	0.924
		-10		0.981	0.962	0.924
		-15			0.962	0.924
Heating			5	10	20	30
Height difference H (m)	Indoor Upper than Outdoor	15			0.988	0.976
		10		0.994	0.988	0.976
		5	1.000	0.994	0.988	0.976
		0	1.000	0.994	0.988	0.976
	Outdoor Upper than Indoor	-5	0.992	0.986	0.980	0.968
		-10		0.978	0.972	0.960
		-15			0.964	0.953

Capacity (Btu/h)	36k		Pipe Length (m)					
Cooling			5	10	15	20	25	30
Height difference H (m)	Indoor Upper than Outdoor	20				0.901	0.883	0.865
		15			0.933	0.915	0.897	0.878
		10		0.966	0.948	0.929	0.910	0.891
		5	0.995	0.976	0.957	0.938	0.919	0.900
		0	1.000	0.981	0.962	0.943	0.924	0.905
	Outdoor Upper than Indoor	-5	1.000	0.981	0.962	0.943	0.924	0.905
		-10		0.981	0.962	0.943	0.924	0.905
-15				0.962	0.943	0.924	0.905	
	-20				0.943	0.924	0.905	
Heating			5	10	15	20	25	30
Height difference H (m)	Indoor Upper than Outdoor	20				0.972	0.963	0.954
		15			0.982	0.972	0.963	0.954
		10		0.991	0.982	0.972	0.963	0.954
		5	1.000	0.991	0.982	0.972	0.963	0.954
		0	1.000	0.991	0.982	0.972	0.963	0.954
	Outdoor Upper than Indoor	-5	0.992	0.983	0.974	0.965	0.955	0.946
		-10		0.975	0.966	0.957	0.948	0.939
-15				0.958	0.949	0.940	0.931	
	-20				0.942	0.933	0.924	

Capacity (Btu/h)	48k		Pipe Length (m)					
Cooling			5	10	20	30	40	50
Height difference H (m)	Indoor Upper than Outdoor	30				0.862	0.825	0.788
		20			0.913	0.875	0.837	0.800
		10		0.966	0.927	0.889	0.850	0.812
		5	0.995	0.976	0.937	0.898	0.859	0.820
	Outdoor Upper than Indoor	0	1.000	0.980	0.941	0.902	0.863	0.824
		-5	1.000	0.980	0.941	0.902	0.863	0.824
		-10		0.980	0.941	0.902	0.863	0.824
		-20			0.941	0.902	0.863	0.824
		-30				0.902	0.863	0.824
Heating			5	10	20	30	40	50
Height difference H (m)	Indoor Upper than Outdoor	30				0.951	0.931	0.911
		20			0.970	0.951	0.931	0.911
		10		0.990	0.970	0.951	0.931	0.911
		5	1.000	0.990	0.970	0.951	0.931	0.911
	Outdoor Upper than Indoor	0	1.000	0.990	0.970	0.951	0.931	0.911
		-5	0.992	0.982	0.963	0.943	0.923	0.904
		-10		0.974	0.955	0.935	0.916	0.896
		-20			0.947	0.928	0.909	0.889
		-30				0.921	0.901	0.882

Capacity (Btu/h)	55k		Pipe Length (m)					
Cooling			5	10	20	30	40	50
Height difference H (m)	Indoor Upper than Outdoor	30				0.846	0.803	0.759
		20			0.904	0.859	0.815	0.770
		10		0.963	0.917	0.872	0.827	0.782
		5	0.995	0.972	0.927	0.881	0.836	0.790
	Outdoor Upper than Indoor	0	1.000	0.977	0.931	0.886	0.840	0.794
		-5	1.000	0.977	0.931	0.886	0.840	0.794
		-10		0.977	0.931	0.886	0.840	0.794
		-20			0.931	0.886	0.840	0.794
		-30				0.886	0.840	0.794
Heating			5	10	20	30	40	50
Height difference H (m)	Indoor Upper than Outdoor	30				0.947	0.926	0.905
		20			0.968	0.947	0.926	0.905
		10		0.989	0.968	0.947	0.926	0.905
		5	1.000	0.989	0.968	0.947	0.926	0.905
	Outdoor Upper than Indoor	0	1.000	0.989	0.968	0.947	0.926	0.905
		-5	0.992	0.982	0.961	0.940	0.919	0.898
		-10		0.974	0.953	0.932	0.911	0.891
		-20			0.945	0.925	0.904	0.883
		-30				0.917	0.897	0.876

9. Noise Criterion Curves

9.1 Indoor Unit

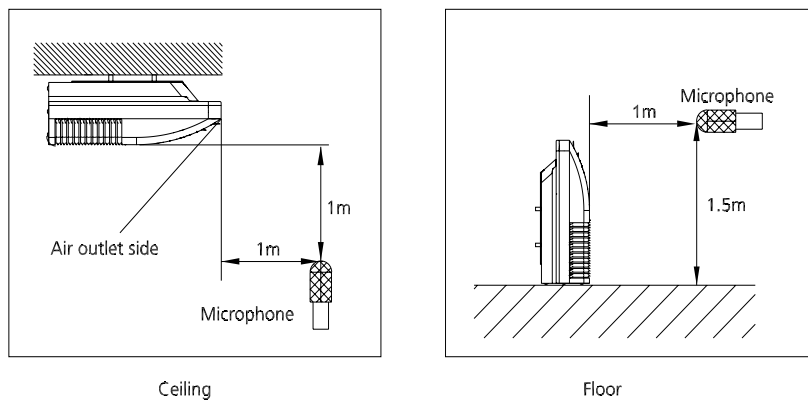

Notes:

- Sound measured at 1.5m away from the center of the unit.
- Data is valid at free field condition
- Data is valid at nominal operation condition
- Reference acoustic pressure $OdB = 20\mu Pa$
- Sound level will vary depending on a range of factors such as the construction -(acoustic absorption coefficient) of particular room in which the equipment is installed.
- The operating conditions are assumed to be standard.

24k

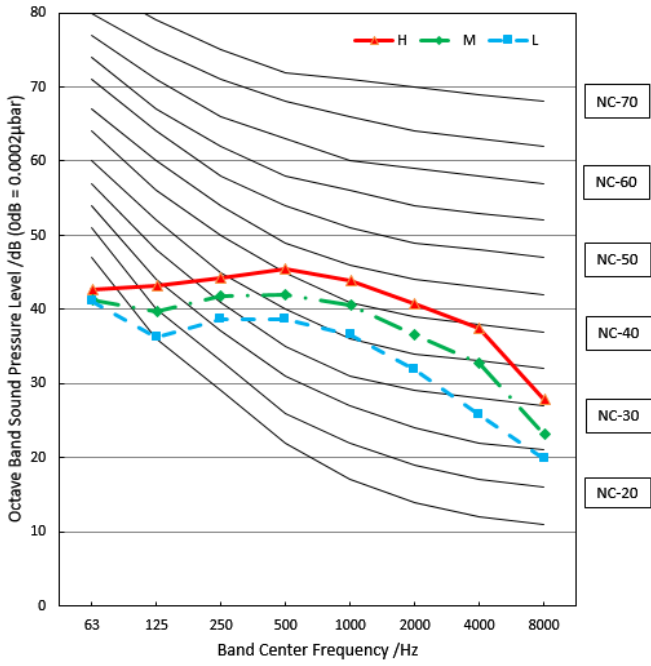

36k

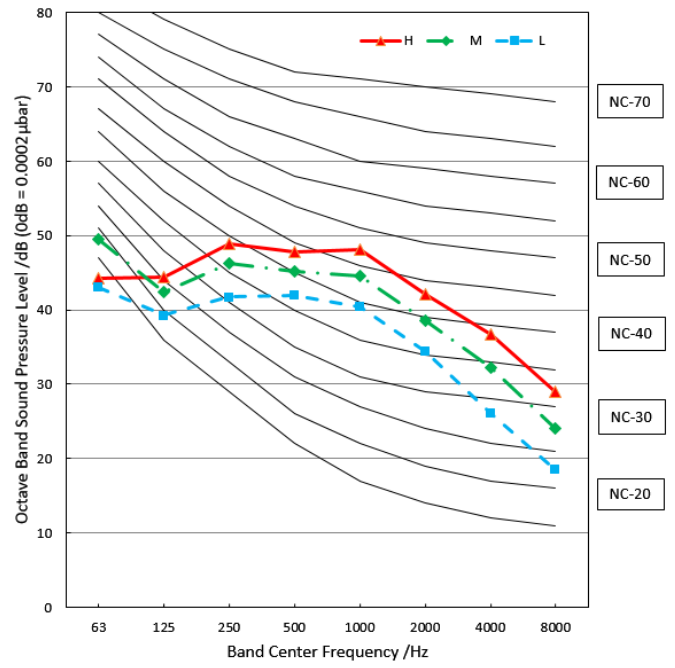

48k

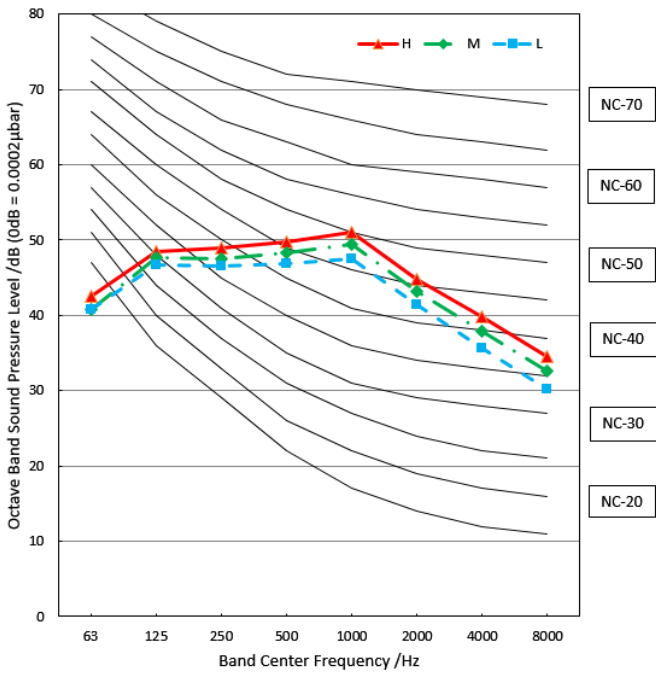

55k

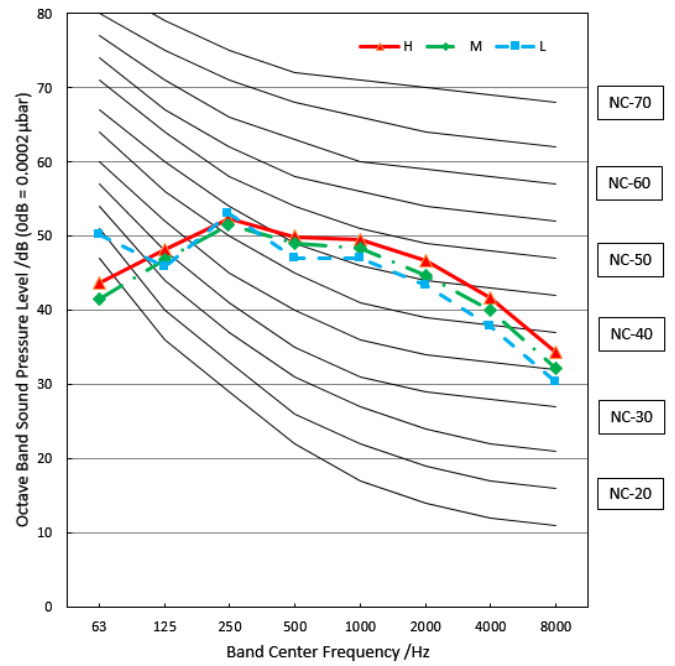

9.2 Outdoor Unit

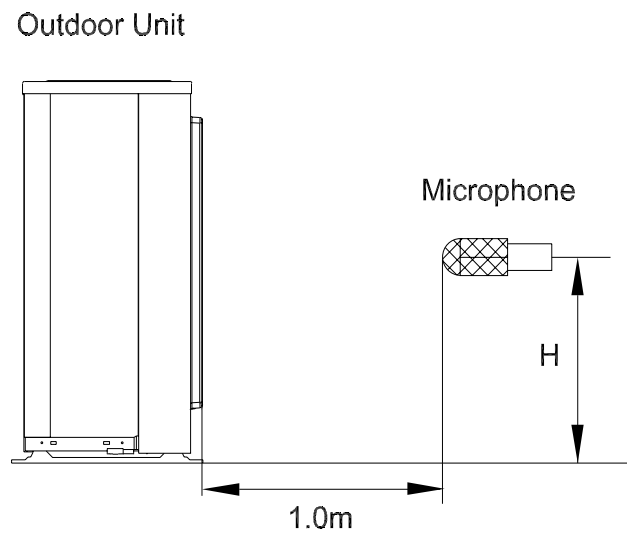

Note: $H = 0.5 \times$ height of outdoor unit

Notes:

- Sound measured at 1.0m away from the center of the unit.
- Data is valid at free field condition
- Data is valid at nominal operation condition
- Reference acoustic pressure $OdB=20\mu Pa$
- Sound level will vary depending on arrangement of factors such as the construction (acoustic absorption coefficient) of particular room in which the equipment is installed.
- The operating conditions are assumed to be standard.

24k

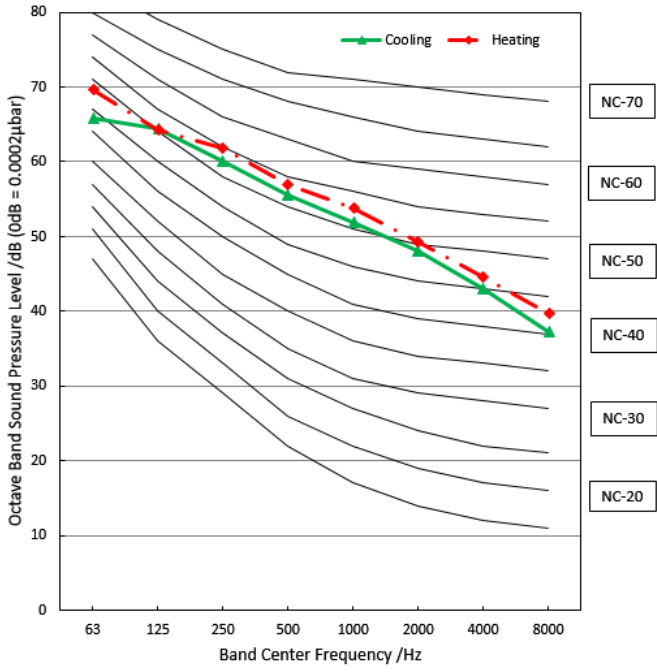

36k

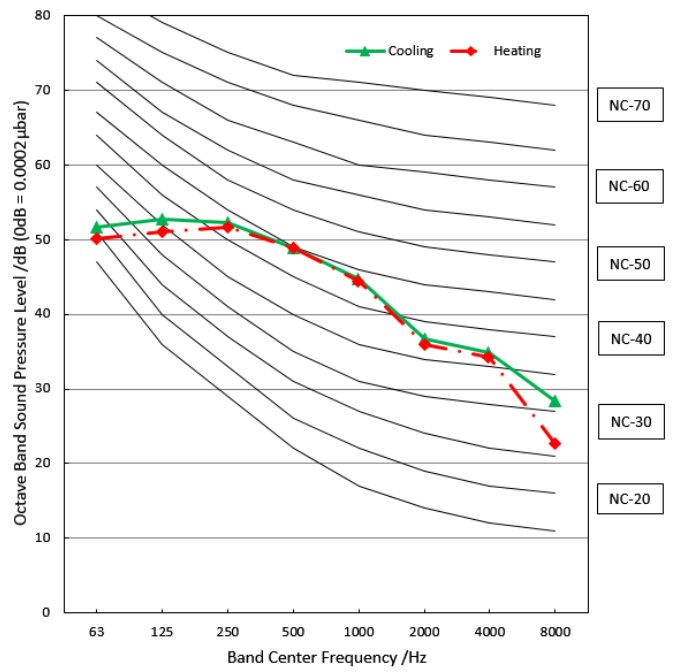

48k

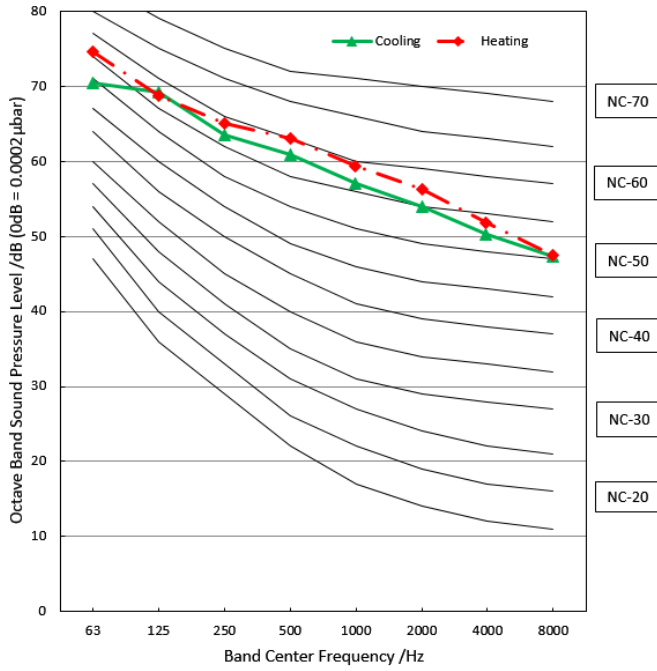

55k

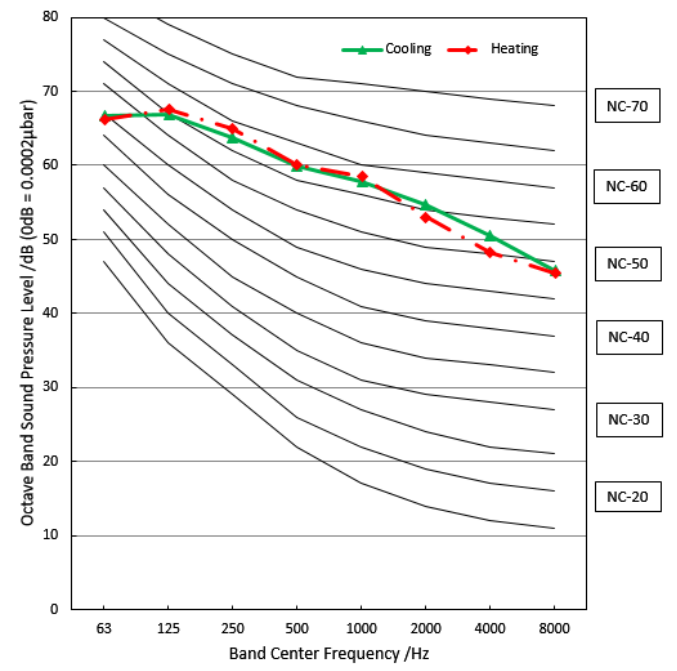

10. Electrical Characteristics

Capacity (Btu/h)		24k	36k	48~55k
OUTDOOR UNIT POWER	Phase	1-phase	3-phase	3-phase
	Frequency and Voltage	220-240V, 50Hz	380-415V, 50Hz	380-415V, 50Hz
	Power Wiring (mm ²)	3×2.5	5×2.5	5×2.5
	Circuit Breaker/ Fuse (A)	25/20	25/20	32/25
Indoor/Outdoor Connecting Wiring	Weak Electric Signal) (mm ²)			
	Strong Electric Signal(mm ²)	4×1.0(4×2.5 with auxiliary electric heater)	4×1.0(4×2.5 with auxiliary electric heater)	4×1.0(4×2.5 with auxiliary electric heater)

NOTE: Electric auxiliary heating type circuit breaker/fuse need to add more than 10 A.

Product Features

Contents

1.	Operation Modes and Functions	78
1.1	Abbreviations	78
1.2	Safety Features	78
1.3	Display Function	78
1.4	Fan Mode.....	78
1.5	Cooling Mode	78
1.6	Heating Mode (Heat pump models).....	79
1.7	Auto Mode	80
1.8	Drying Mode	81
1.9	Forced Operation Function	81
1.10	Timer Function	81
1.11	Sleep Function.....	81
1.12	Auto-Restart.....	81
1.13	8°C Heating (Optional)	82
1.14	Follow Me	82
1.15	Silence(Optional)	82
1.16	ECO (Optional)	82
1.17	Electrical energy consumption control function(Optional).....	82
1.18	Active Clean function(Optional)	82
2.	Remote Controller Functions	83
3.1	Infrared Wireless Remote Controller.....	83
3.2	LCD Wired Remote Controller	93
3.3	Centralized Controller	109

1. Operation Modes and Functions

1.1 Abbreviation

Unit element abbreviations

Abbreviation	Element
T1	Indoor room temperature
T2	Coil temperature of evaporator
T3	Coil temperature of condenser
T4	Outdoor ambient temperature
TP	Compressor discharge temperature
Tsc	Adjusted setting temperature

In this manual, such as CDIFTEMP, HDIFTEMP2, TCE1, TCE2...etc., they are well-setting parameter of EEPROM.

1.2 Safety Features

Compressor three-minute delay at restart

Compressor functions are delayed for up to ten seconds upon the first startup of the unit, and are delayed for up to three minutes upon subsequent unit restarts.

Automatic shutoff based on discharge temperature

If the compressor discharge temperature exceeds a certain level for nine seconds, the compressor ceases operation.

Automatic shutoff based on fan speed

If the indoor fan speed registers below 200RPM or over 2100RPM for an extended period of time, the unit ceases operation

Inverter module protection

The inverter module has an automatic shutoff mechanism based on the unit's current, voltage, and temperature. If automatic shutoff is initiated, the corresponding error code is displayed on the indoor unit and the unit ceases operation.

Indoor fan delayed operation

- When the unit starts, the louver is automatically activated and the indoor fan will operate after a period of setting time or the louver is in place.
- If the unit is in heating mode, the indoor fan is regulated by the anti-cold wind function.

Compressor preheating

Preheating is automatically activated when T4 sensor is lower than setting temperature.

Sensor redundancy and automatic shutoff

- If one temperature sensor malfunctions, the air conditioner continues operation and displays the corresponding error code, allowing for emergency use.
- When more than one temperature sensor is malfunctioning, the air conditioner ceases operation.

1.3 Display Function

Unit display functions

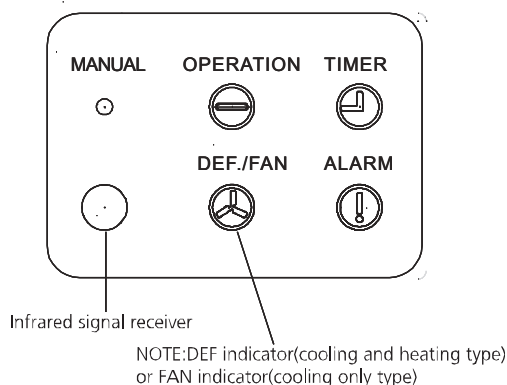

1.4 Fan Mode

When fan mode is activated:

- The outdoor fan and compressor are stopped.
- Temperature control is disabled and no temperature setting is displayed.
- The indoor fan speed can be set to 1%~100%, or low, medium, high and auto.
- The louver operations are identical to those in cooling mode.
- Auto fan: In fan-only mode, AC operates the same as auto fan in cooling mode with the temperature set at 24°C.

1.5 Cooling Mode

1.5.1 Compressor Control

Reach the configured temperature:

- 1) When the compressor runs continuously for less than 120 minutes.
 - If the following conditions are satisfied, the compressor ceases operation.
 - Calculated frequency(fb) is less than minimum limit frequency(FminC).
 - Compressor runs at FminC more than ten minutes.
 - T1 is lower than or equal to (Tsc-CDIFTEMP-0.5°C)
- 2) When the compressor runs continuously for more than 120 minutes.

- If the following conditions are satisfied, the compressor ceases operation.
 - Calculated frequency(f_b) is less than minimum limit frequency(F_{minC}).
 - Compressor runs at F_{minC} more than 10 minutes.
 - When T_1 is lower than or equal to $(T_{sc}-CDIFTEMP)$.
- 3) If one of the following conditions is satisfied, not judge protective time.
- Compressor running frequency is more than test frequency.
 - When compressor running frequency is equal to test frequency, T_4 is more than 15°C or T_4 fault.
 - Change setting temperature.
 - Turbo or sleep function on/off
 - Various frequency limit shutdown occurs.

1.5.2 Indoor Fan Control

1) In cooling mode, the indoor fan operates continuously. The fan speed can be set to 1%-100%, or low, medium, high and auto.

2) Auto fan action in cooling mode:

- Descent curve
 - When T_1-T_{sc} is lower than or equal to 3.5°C , fan speed reduces to 80%;
 - When T_1-T_{sc} is lower than or equal to 1°C , fan speed reduces to 60%;
 - When T_1-T_{sc} is lower than or equal to 0.5°C , fan speed reduces to 40%;
 - When T_1-T_{sc} is lower than or equal to 0°C , fan speed reduces to 20%;
 - When T_1-T_{sc} is lower than or equal to -0.5°C , fan speed reduces to 1%.
- Rise curve
 - When T_1-T_{sc} is higher than 0°C , fan speed increases to 20%;
 - When T_1-T_{sc} is higher than 0.5°C , fan speed increases to 40%;
 - When T_1-T_{sc} is higher than 1°C , fan speed increases to 60%;
 - When T_1-T_{sc} is higher than 1.5°C , fan speed increases to 80%;
 - When T_1-T_{sc} is higher than 4°C , fan speed increases to 100%.

1.5.3 Outdoor Fan Control

- The outdoor unit will be run at different fan speed according to T_4 and compressor frequency.
- For different outdoor units, the fan speeds are different.

1.5.4 Condenser Temperature Protection

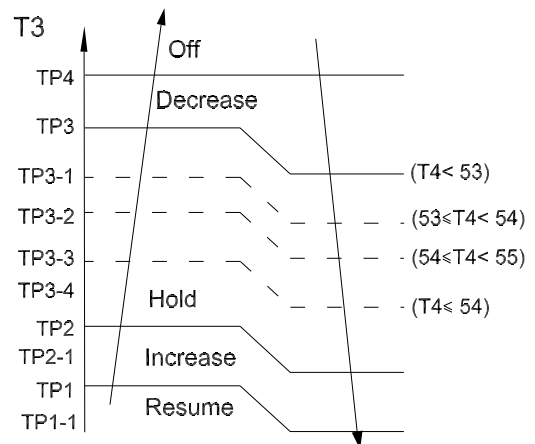

When the condenser temperature exceeds a configured value, the compressor ceases operation.

1.5.5 Evaporator Temperature Protection

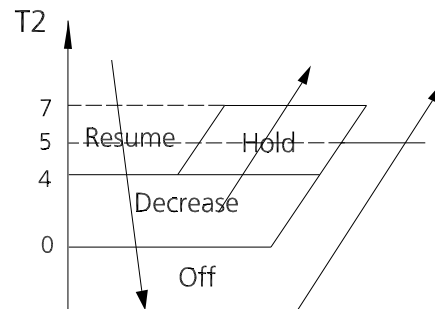

- Off: Compressor stops.
- Decrease: Decrease the running frequency to the lower level per 1 minute.
- Hold: Keep the current frequency.
- Resume: No limitation for frequency.

1.6 Heating Mode(Heat Pump Units)

1.6.1 Compressor Control

1) Reach the configured temperature

- If the following conditions are satisfied, the compressor ceases operation.
 - Calculated frequency(f_b) is less than minimum limit frequency(F_{minH}).
 - Compressor runs at F_{minH} more than 10 minutes.
 - T_1 is higher than or equal to $T_{sc}+HDIFTEMP2$.

Note: HDIFTEMP2 is EEPROM setting parameter. It is 2°C usually.

- If one of the following conditions is satisfied, not judge protective time.
 - Compressor running frequency is more than test frequency.
 - Compressor running frequency is equal to test

frequency, T4 is more than 15°C or T4 fault.

- Change setting temperature.
 - Turbo or sleep function on/off.
- 2) When the current is higher than the predefined safe value, surge protection is activated, causing the compressor to cease operations.

1.6.2 Indoor Fan Control:

1) In heating mode, the indoor fan operates continuously. The fan speed can be set to 1%-100%, or low, medium, high and auto.

- Anti-cold air function
 - The indoor fan is controlled by the indoor temperature T1 and indoor unit coil temperature T2.

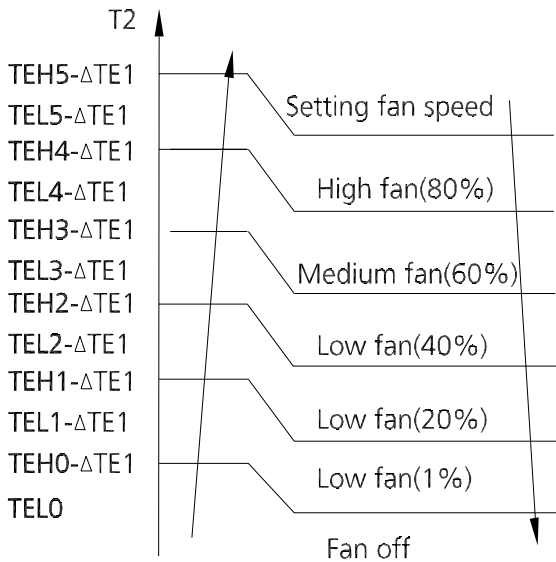

$\Delta TE1=0$

2) Auto fan action in heating mode:

- Rise curve
 - When T1-Tsc is higher than -1.5°C, fan speed reduces to 80%;
 - When T1-Tsc is higher than 0°C, fan speed reduces to 60%;
 - When T1-Tsc is higher than 0.5°C, fan speed reduces to 40%;
 - When T1-Tsc is higher than 1°C, fan speed reduces to 20%.
- Descent curve
 - When T1-Tsc is lower than or equal to 0.5°C, fan speed increases to 40%;
 - When T1-Tsc is lower than or equal to 0°C, fan speed increases to 60%;
 - When T1-Tsc is lower than or equal to -1.5°C, fan

speed increases to 80%;

- When T1-Tsc is lower than or equal to -3°C, fan speed increases to 100%.

1.6.3 Outdoor Fan Control:

- The outdoor unit will be run at different fan speed according to T4 and compressor frequency.
- For different outdoor units, the fan speeds are different.

1.6.4 Defrosting mode

- The unit enters defrosting mode according to the temperature value of T3 and T4 as well as the compressor running time.
- In defrosting mode, the compressor continues to run, the indoor and outdoor motor will cease operation, the defrost light of the indoor unit will turn on, and the "df" symbol is displayed.
- If any one of the following conditions is satisfied, defrosting ends and the machine switches to normal heating mode:
 - T3 rises above TCDE1.
 - T3 maintained above TCDE2 for 80 seconds.
 - Unit runs for 15 minutes consecutively in defrosting mode.
- If T4 is lower than or equal to -22°C and compressor running time is more than TIMING_DEFROST_TIME, if any one of the following conditions is satisfied, defrosting ends and the machine switches to normal heating mode:
 - Unit runs for 10 minutes consecutively in defrosting mode.
 - T3 rises above 10°C.

1.6.5 Evaporator Coil Temperature Protection

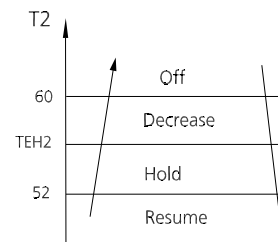

- Off: Compressor stops.
- Decrease: Decrease the running frequency to the lower level per 20 seconds.
- Hold: Keep the current frequency.
- Resume: No limitation for frequency.

1.7 Auto-mode

- This mode can be selected with the remote controller and the temperature setting can be adjusted between 16°C~30°C.

Case 1:

- In auto mode, the machine selects cooling, heating, or fan-only mode on the basis of ΔT ($\Delta T = T1 - T5$).

ΔT	Running mode
$\Delta T > 2^{\circ}\text{C} (3.6^{\circ}\text{F})$	Cooling
$-3^{\circ}\text{C} (-5.4^{\circ}\text{F}) \leq \Delta T \leq 2^{\circ}\text{C} (3.6^{\circ}\text{F})$	Fan-only
$\Delta T < -3^{\circ}\text{C} (-5.4^{\circ}\text{F})$	Heating*

Heating*: In auto mode, cooling only models run the fan

- Indoor fan will run at auto fan speed.
- The louver operates same as in relevant mode.
- If the machine switches mode between heating and cooling, the compressor will keep stopping for certain time and then choose mode according to ΔT .

1.8 Drying mode

- In drying mode, AC operates the same as auto fan in cooling mode.
- All protections are activated and operate the same as they do that in cooling mode.
- Low Room Temperature Protection

If the room temperature is lower than 10°C , the compressor ceases operations and does not resume until room temperature exceeds 12°C .

1.9 Forced operation function

Press the AUTO/COOL button, the AC will run as below sequence:

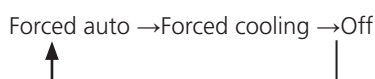

- Forced cooling mode:

The compressor and outdoor fan continue to run and the indoor fan runs at breeze speed. After running for 30 minutes, the AC will switch to auto mode with a preset temperature of $24^{\circ}\text{C} (76^{\circ}\text{F})$.

- Forced auto mode:

Forced auto mode operates the same as normal auto mode with a preset temperature of $24^{\circ}\text{C} (76^{\circ}\text{F})$.

- The unit exits forced operation when it receives the following signals:
 - Switch off
 - Changes in:
 - mode
 - fan speed
 - sleep mode
 - Follow me

1.10 Timer Function

- The timing range is 24 hours.
- Timer On. The machine turns on automatically at the preset time.
- Timer Off. The machine turns off automatically at the preset time.
- Timer On/Off. The machine turns on automatically at the preset On Time, and then turns off automatically at the preset Off Time.
- Timer Off/On. The machine turns off automatically at the preset Off Time and then turns on automatically at the preset On Time.
- The timer does not change the unit operation mode. If the unit is off now, it does not start up immediately after the "timer off" function is set. When the setting time is reached, the timer LED switches off and the unit running mode remains unchanged.
- The timer uses relative time, not clock time

1.11 Sleep function

- The sleep function is available in cooling, heating, or auto mode.
- The operational process for sleep mode is as follows:
 - When cooling, the temperature rises 1°C (to not higher than $30^{\circ}\text{C} / 86^{\circ}\text{F}$) every hour. After 2 hours, the temperature stops rising and the indoor fan is fixed at low speed.
 - When heating, the temperature decreases 1°C (to not lower than $16^{\circ}\text{C} / 60.8^{\circ}\text{F}$) every hour. After 2 hours, the temperature stops decreasing and the indoor fan is fixed at low speed. Anti-cold wind function takes priority.
- The operating time for sleep mode is 8 hours, after which, the unit exits this mode.
- The timer setting is available in this mode.

1.12 Auto-Restart function

- The indoor unit has an auto-restart module that allows the unit to restart automatically. The module automatically stores the current settings and in the case of a sudden power failure, will restore those setting automatically within 3 minutes after power returns.

1.13 8°C Heating (Optional)

In heating mode, the temperature can be set to as low as 8°C, preventing the indoor area from freezing if unoccupied during severe cold weather.

1.14 Follow me

- If you press “Follow Me” on the remote, the indoor unit will beep. This indicates the follow me function is active.
- Once active, the remote control will send a signal every 3 minutes, with no beeps. The unit automatically sets the temperature according to the measurements from the remote control.
- The unit will only change modes if the information from the remote control makes it necessary, not from the unit’s temperature setting.
- If the unit does not receive a signal for 7 minutes or you press “Follow Me,” the function turns off. The unit regulates temperature based on its own sensor and settings.

1.15 Silence(Optional)

- Press “Silence” or keep pressing Fan button for more than 2 seconds on the remote control to enable the SILENCE function. While this function is active, the compressor frequency is maintained at a lower level than F3. The indoor unit will run at faint breeze(1%), which reduces noise to the lowest possible level.
- When match with multi outdoor unit, this function is disabled.

1.16 ECO Function(Optional)

- Used to enter the energy efficient mode.
 - Under cooling mode, press ECO button, the remote controller will adjust the temperature automatically to 24°C/75°F, fan speed of Auto to save energy (but only if the set temperature is less than 24°C/75°F). If the set temperature is more than 24°C/75°F and 30°C/86°F, press the ECO button, the fan speed will change to Auto, the set temperature will remain unchanged.
- When pressing the ECO button, or modifying the mode or adjusting the set temperature to less than 24°C/75°F, the AC will quit the ECO operation.
- Operation time in ECO mode is 8 hours. After 8 hours the AC quits this mode.

1.17 Electrical energy consumption control function (Optional)

Press the “Gear” button on remote controller to enter the energy efficient mode in a sequence of following:

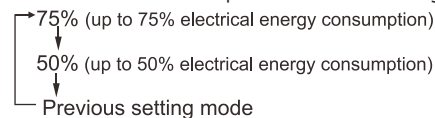

Turn off the unit or activate ECO, sleep, Super cool, 8°C Heating, Silence or self clean function will quit this function.

1.18 Active Clean function(Optional)

- The Active Clean Technology washes away dust, mold, and grease that may cause odors when it adheres to the heat exchanger by automatically freezing and then rapidly thawing the frost. The internal wind wheel then keeps operating to blow-dry the evaporator, thus preventing the growth of mold and keeping the inside clean.
- When this function is turned on, the indoor unit display window appears “CL”, after 20 to 45 minutes, the unit will turn off automatically and cancel Active Clean function.

2. Remote Controller Functions

2.1 Infrared Wireless Remote Controller

2.1.1 RG10A(B2S)/BGEF (Standard for some models)

Remote Controller Specifications

Model	RG10A(B2S)/BGEF
Rated Voltage	3.0V (Dry batteries R03/LR03×2)
Reaching Distance	8m
Environment Temperature Range	-5°C~60°C(23°F~140°F)

Buttons and Functions

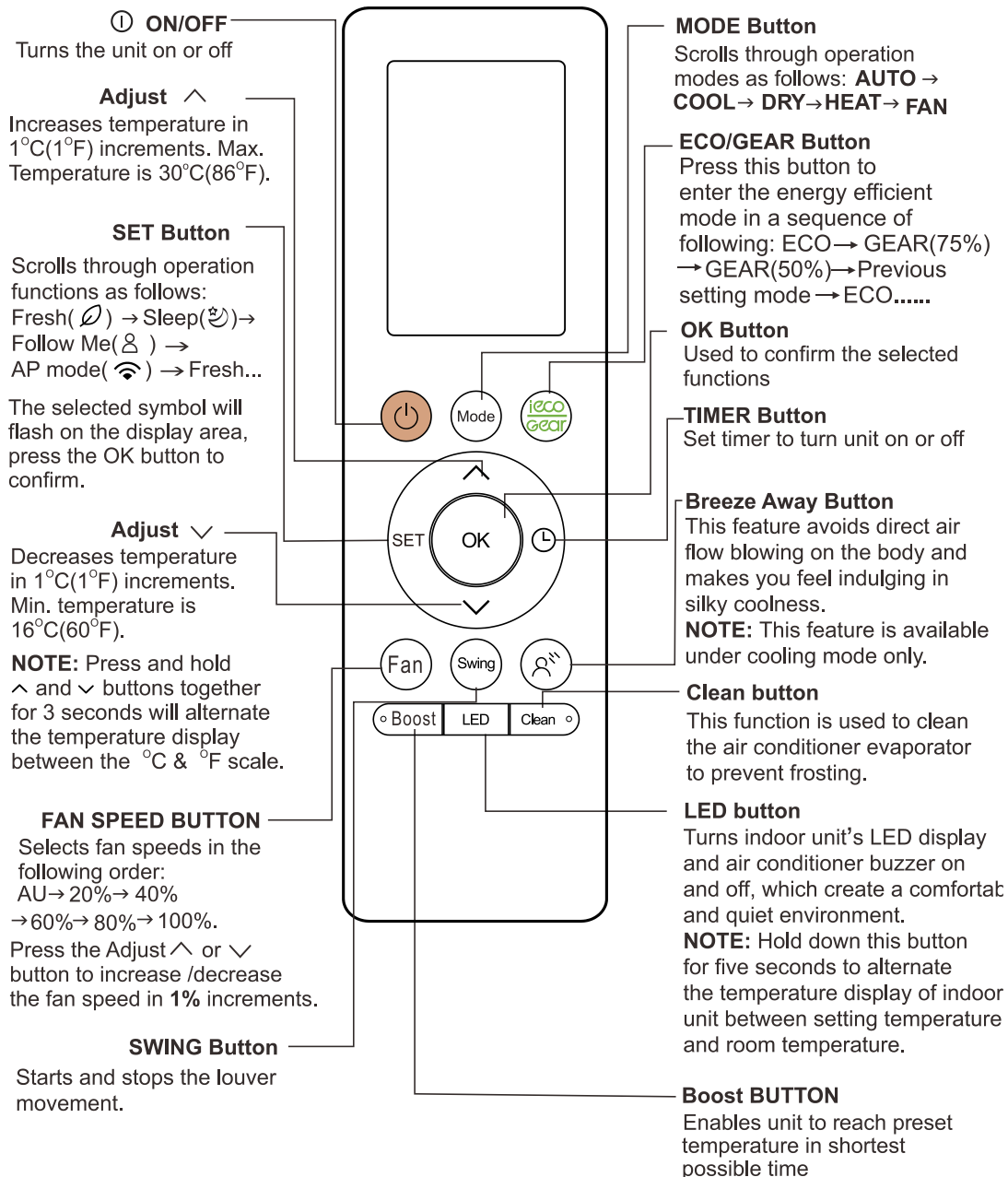

Remote LCD Screen Indicators

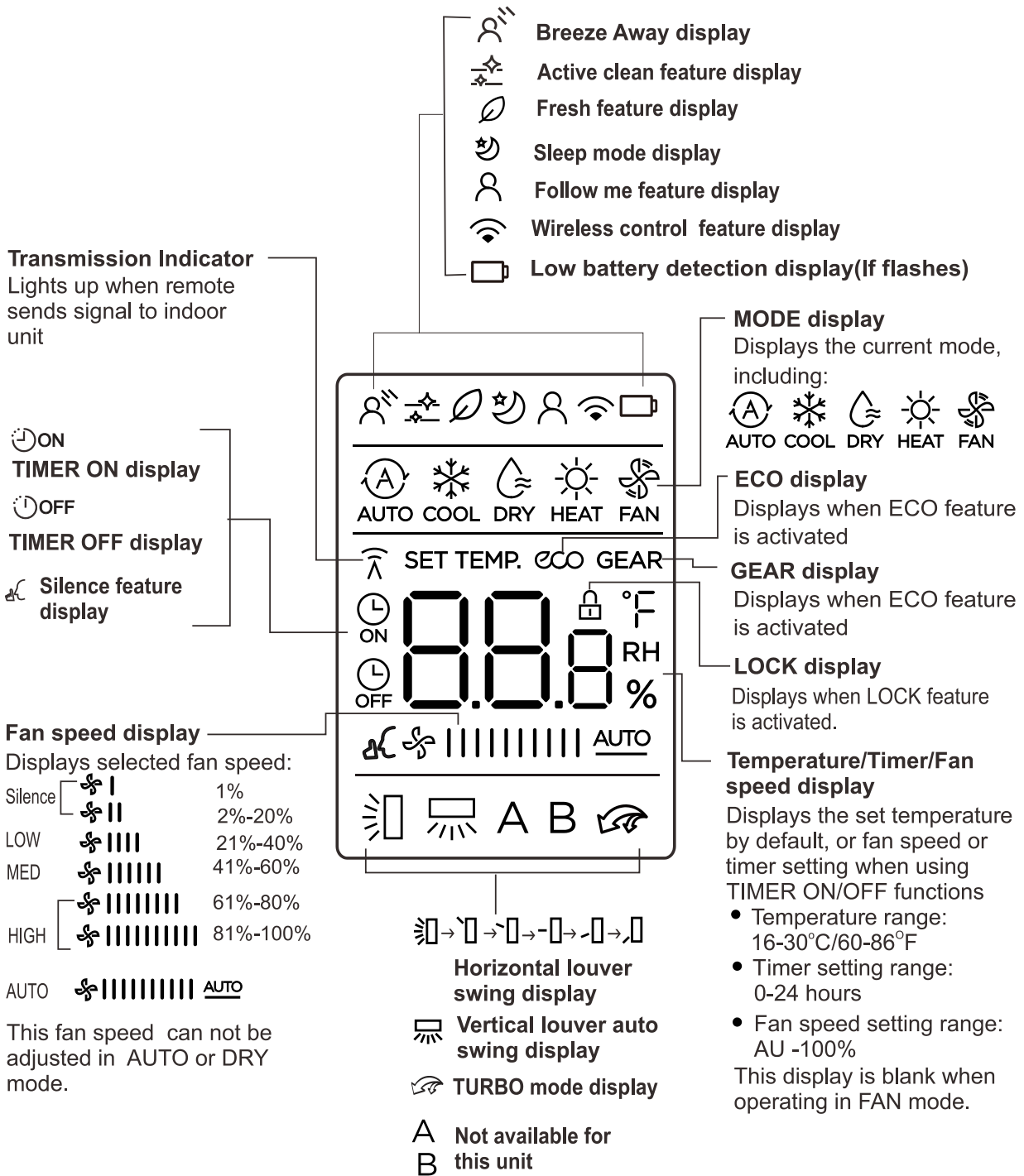

How To Use The Basic Functions

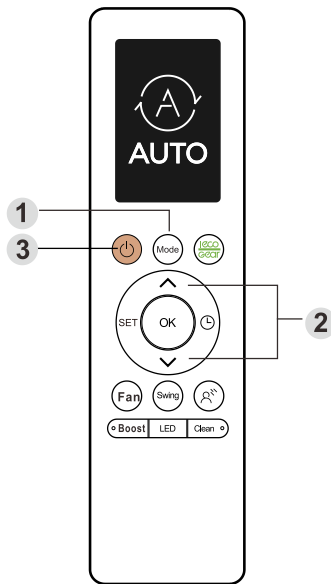

COOL Operation

1. Press the MODE button to select COOL mode.
2. Set your desired temperature using the Temp ▲ or Temp ▼ button.
3. Press the FAN button to select the fan speed in a range of Au-100%, in conjunction with Temp ▲ or Temp ▼ button.
4. Press the ON/OFF button to start the unit.

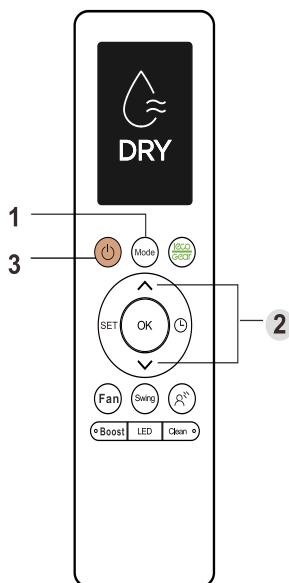

Setting Temperature

The operating temperature range for units is 16-30°C/60-86°F. You can increase or decrease the set temperature in 0.5°C/1°F increments.

AUTO Operation

In AUTO mode, the unit will automatically select the COOL, FAN, HEAT or DRY mode based on the set temperature.

1. Press the MODE button to select Auto mode.
2. Set your desired temperature using the Temp ▲ or Temp ▼ button.
3. Press the ON/OFF button to start the unit.

NOTE: FAN SPEED can't be set in Auto mode.

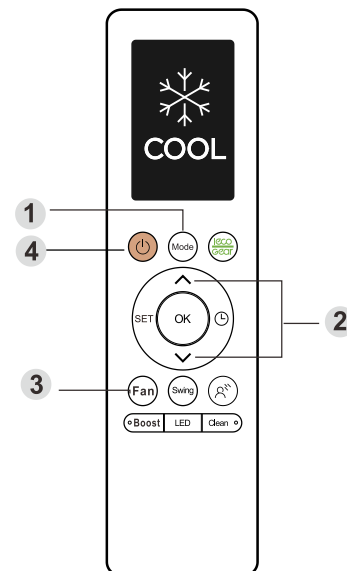

DRY Operation(dehumidifying)

1. Press the MODE button to select DRY mode.
2. Set your desired temperature using the Temp ▲ or Temp ▼ button.
3. Press the ON/OFF button to start the unit.

NOTE: FAN SPEED can't be changed in DRY mode.

FAN Operation

1. Press the MODE button to select FAN mode.
2. Press the FAN button to select the fan speed in a range of Au-100%, in conjunction with Temp ▲ or Temp ▼ button.
3. Press the ON/OFF button to start the unit.

NOTE: You can't set temperature in FAN mode. As a result, your remote control sLCD screen will not display temperature.

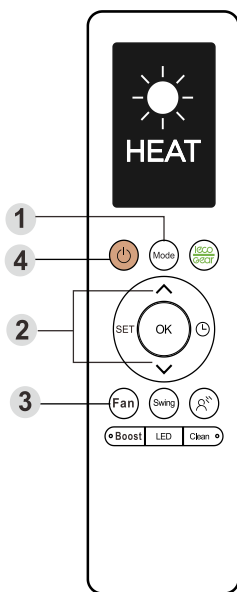
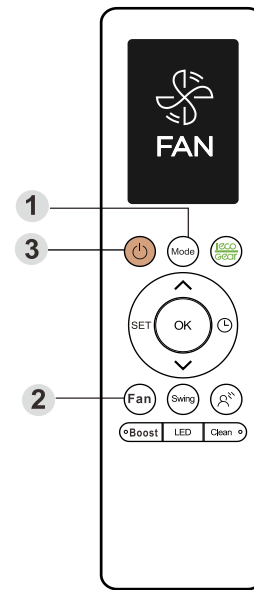

HEAT Operation

1. Press the MODE button to select HEAT mode.
2. Set your desired temperature using the Temp ▲ or Temp ▼ button.
3. Press the FAN button to select the fan speed in a range of Au-100%, in conjunction with Temp ▲ or Temp ▼ button.
4. Press the ON/OFF button to start the unit.

NOTE: As outdoor temperature drops, the performance of your unit's HEAT function may be affected. In such instances, we recommend using this air conditioner in conjunction with other heating appliance.

How To Use The Advanced Functions

- Press the SET button to enter the function setting, then press SET button or Temp ▲ or Temp ▼ button to select the desired function. The selected symbol will flash on the display area, press the OK button to confirm.
- To cancel the selected function, just perform the same procedures as above.
- Press the SET button to scroll through operation functions as follows:

Fresh (🌿) --> Sleep (🌙) --> Follow Me (👤) --> AP Mode (🏠)

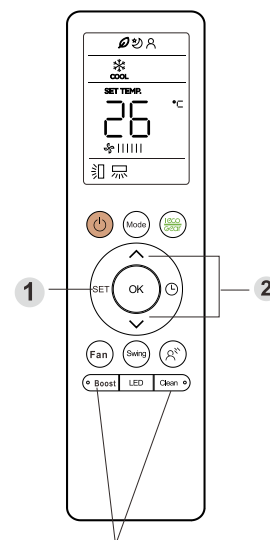

Press and hold **Boost** and **Clean** buttons together for five seconds to lock the keypads. Press and hold **Turbo** and **Clean** buttons together for two seconds to cancel.

ECO/GEAR Function

NOTE: This function is only available under COOL mode.

Press ECO/GEAR button to enter the energy efficient mode in a sequence of following:

ECO -->GEAR(75%) -->GEAR(50%) --> Previous setting mode -->ECO.....

ECO operation:

Under cooling mode, press this button, the remote controller will adjust the temperature automatically to 24°C, fan speed of Auto to save energy (but only if the set temperature is less than 24°C). If the set temperature is above 24°C, press the ECO button, the fan speed will change to Auto, the set temperature will remain unchanged.

NOTE:

- Pressing the ON/OFF button, modifying the mode or adjusting the set temperature to less than 24°C will stop ECO operation.
- Under ECO operation, the set temperature should be 24°C or higher. It may result in insufficient cooling. If you feel uncomfortable, just press the ECO button again to stop it.

GEAR operation:

- Press this button to enter the energy efficient mode in a sequence of following:

75% (up to 75% electrical energy consumption)





50% (up to 50% electrical energy consumption)



Previous setting mode

- This function is only available under COOL mode.
- Under GEAR operation, the display on the remote controller will alternate between electrical energy consumption and set temperature.

TEMP Button

Press and hold  and  buttons together for 3 seconds will alternate the temperature display between the °C & °F scale.

FP Function

When the air conditioner operates under heating mode with the set temperature of 16°C (60°F), pressing  button twice in two seconds will activate 8°C (46°F) heating. The indoor unit display shows "FP".

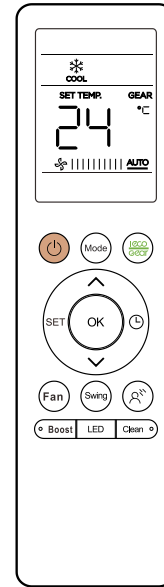

Active Clean Function

- This function is used to clean the air conditioner evaporator to prevent frosting.
- When this function is turned on, the indoor unit display window appears "CL", after 20 to 45 minutes, the unit will turn off automatic.

Silence Function

Hold down Fan speed button  for 2 seconds to activate/cancel Silent mode.

Boost Function

The Boost function makes the unit work extra hard to reach your present temperature in the shortest amount of time possible.

Swing Button

- Press the Swing button to start or stop the horizontal louver auto swing feature. If continue to press the Swing button, five different airflow directions can be set. The louver can be move at a certain range each time you press the button.
- Hold down the Swing button for 2 seconds will start or stop the vertical louver auto swing feature.

NOTE:

- When the unit is off, press and hold **Mode** and **Swing** buttons together for one second, the louver will open for a certain angle, which makes it very convenient for cleaning.
- Press and hold **Mode** and **Swing** buttons together for one second to reset the louver.

2.1.2 RG10B(B2)/BGEF (Standard for some models)

Remote Controller Specifications

Model	RG10B(B2)/BGEF
Rated Voltage	3.0V (Dry batteries R03/LR03×2)
Reaching Distance	8m
Environment Temperature Range	-5°C~60°C(23°F~140°F)

Buttons and Functions

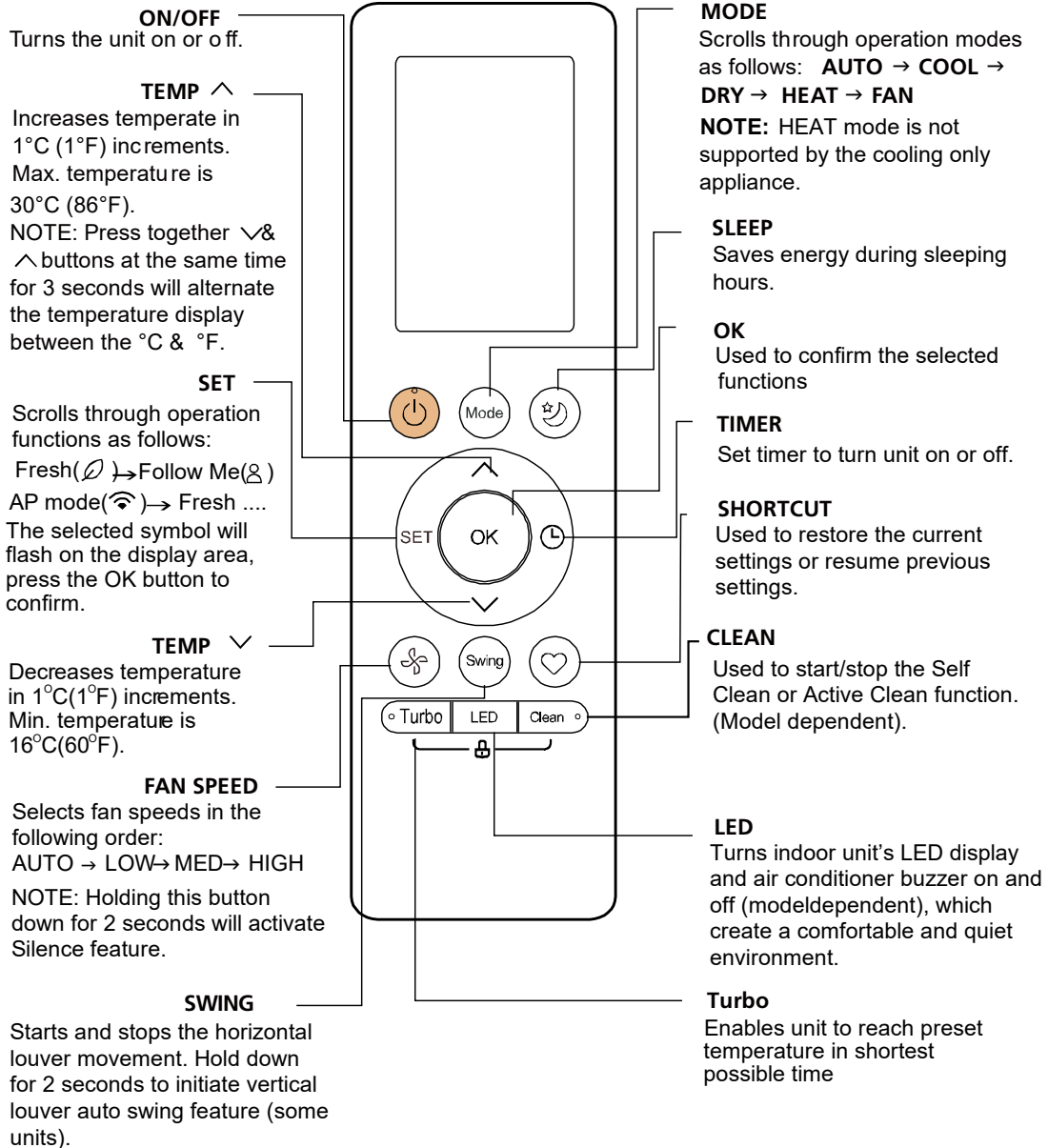

Remote LCD Screen Indicators

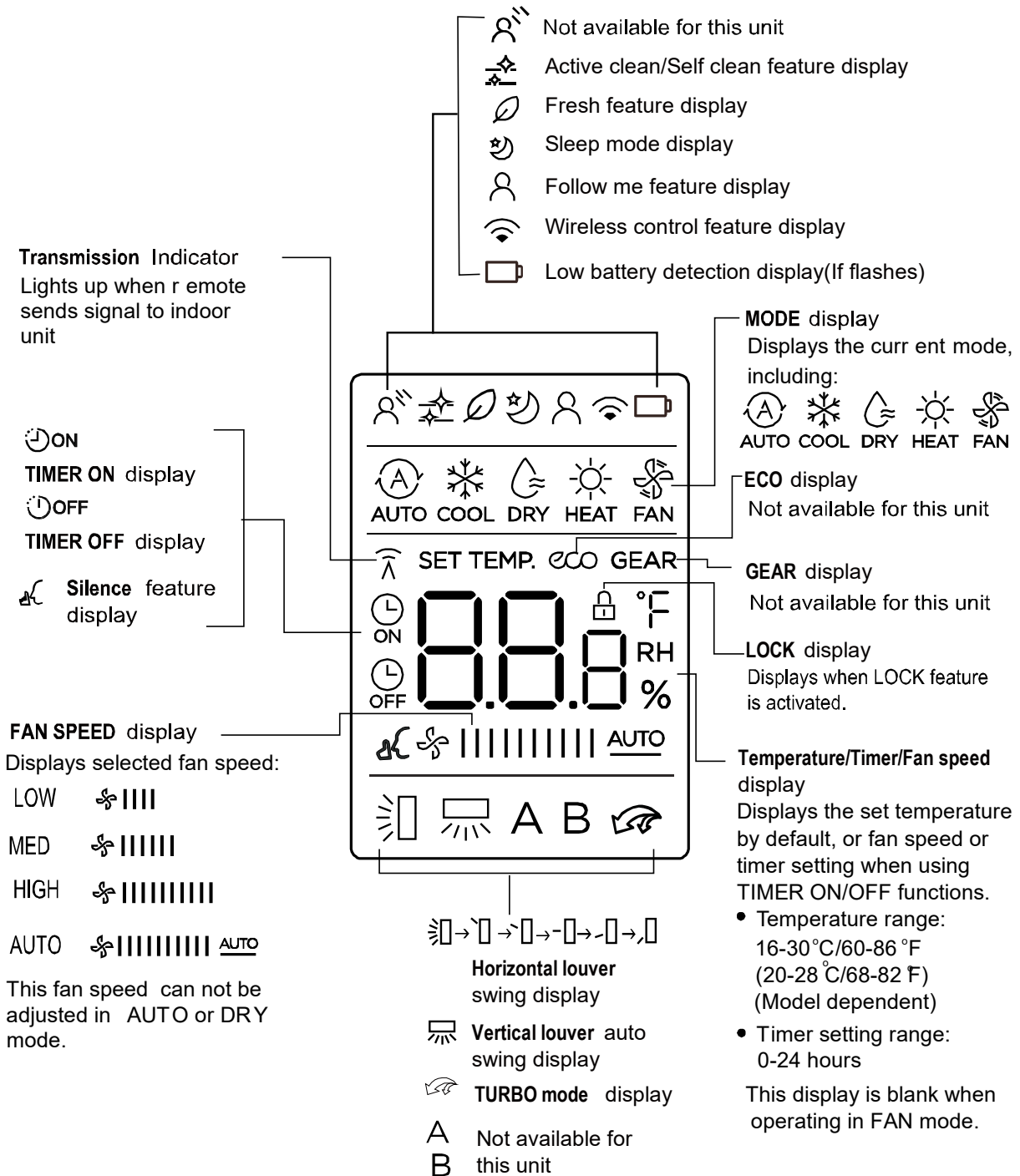

How To Use The Basic Functions

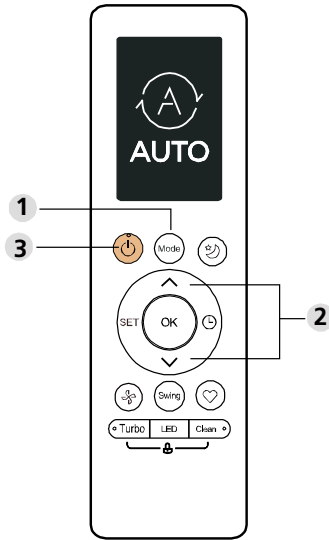

COOL Operation

1. Press the MODE button to select COOL mode.
2. Set your desired temperature using the Temp ▲ or Temp ▼ button.
3. Press the FAN button to select the fan speed in a range of Au-100%, in conjunction with Temp ▲ or Temp ▼ button.
4. Press the ON/OFF button to start the unit.

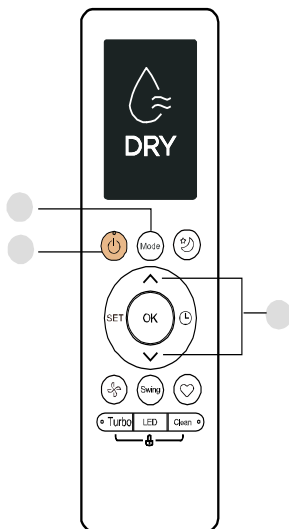

Setting Temperature

The operating temperature range for units is 16-30°C/60-86°F. You can increase or decrease the set temperature in 0.5°C/1°F increments.

AUTO Operation

In AUTO mode, the unit will automatically select the COOL, FAN, HEAT or DRY mode based on the set temperature.

1. Press the MODE button to select Auto mode.
2. Set your desired temperature using the Temp ▲ or Temp ▼ button.
3. Press the ON/OFF button to start the unit.

NOTE: FAN SPEED can't be set in Auto mode.

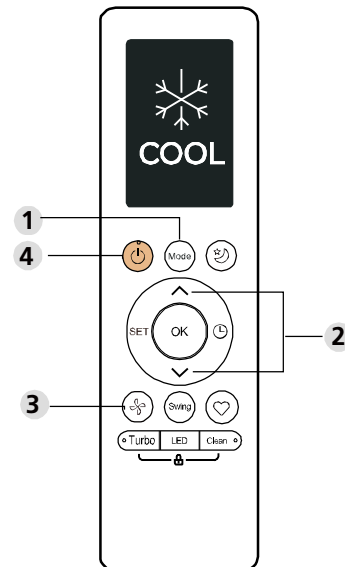

DRY Operation(dehumidifying)

1. Press the MODE button to select DRY mode.
2. Set your desired temperature using the Temp ▲ or Temp ▼ button.
3. Press the ON/OFF button to start the unit.

NOTE: FAN SPEED can't be changed in DRY mode.

FAN Operation

1. Press the MODE button to select FAN mode.
2. Press the FAN button to select the fan speed in a range of Au-100%, in conjunction with Temp ▲ or Temp ▼ button.
3. Press the ON/OFF button to start the unit.

NOTE: You can't set temperature in FAN mode. As a result, your remote control sLCD screen will not display temperature.

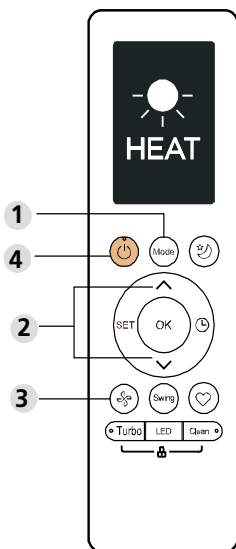
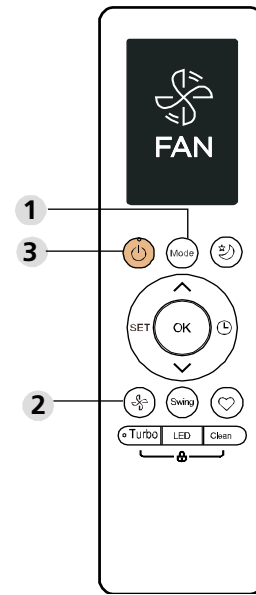



HEAT Operation



1. Press the MODE button to select HEAT mode.
2. Set your desired temperature using the Temp ▲ or Temp ▼ button.
3. Press the FAN button to select the fan speed in a range of Au-100%, in conjunction with Temp ▲ or Temp ▼ button.
4. Press the ON/OFF button to start the unit.

NOTE: As outdoor temperature drops, the performance of your unit's HEAT function may be affected. In such instances, we recommend using this air conditioner in conjunction with other heating appliance.

How To Use The Advanced Functions

SET Function

- Press the SET button to enter the function setting, then press SET button or Temp  or Temp  button to select the desired function. The selected symbol will flash on the display area, press the OK button to confirm.
- To cancel the selected function, just perform the same procedures as above.
- Press the SET button to scroll through operation functions as follows:

Follow Me()--> AP Mode()

Swing Button

- The horizontal louver will swing up and down automatically when pressing Swing button. Press again to make it stop.
- Hold down the Swing button for 2 seconds will start or stop the vertical louver auto swing feature.

Airflow Direction

If continue to press the SWING button, five different airflow directions can be set. The louver can be move at a certain range each time you press the button. Press the button until the direction you prefer is reached.

SHORTCUT Function

- Push SHORTCUT button when remote controller is on, the system will automatically revert back to the previous settings including operating mode, setting temperature, fan speed level and sleep feature (if activated).
- If pushing more than 2 seconds, the system will automatically restore the current operation settings including operating mode, setting temperature, fan speed level and sleep feature (if activated).

Turbo Function

- When you select turbo feature in COOL mode, the unit will blow cool air with strongest wind setting to jump-start the cooling process.
- When you select turbo feature in HEAT mode, for units with Electric heat elements, the Electric HEATER will activate and jump-start the heating process.

LED Display

- Press this button to turn on and turn off the display on the indoor unit.
- Keep pressing this button more than 5 seconds, the indoor unit will display the actual room temperature. Press more than 5 seconds again will revert back to display the setting temperature.

Lock Function

Press together Turbo button and Clean button at the same time more than 5 seconds to activate Lock function.

All buttons will not response except pressing these two buttons for two seconds again to disable locking.

Silence Function

Keep pressing Fan button for more than 2 seconds to activate/disable Silence function(some units).

SLEEP Function

The SLEEP function is used to decrease energy while you sleep(and don't need the same temperature settings to stay comfortable). This function can only by activated via remote control.

Note:The SLEEP function is not available in FAN or DRY mode.

FP Function

The unit will operate at high fan speed (while compressor on) with temperature automatically set to 8°C(46°F), pressing  button twice in one seconds under HEAT Mode and setting temperature of 16°C(60°F) heating. The indoor unit display shows "FP".

Press On/Off, Sleep, Mode, Fan and Temp. button while operating will cancel this function.

2.2 LCD Wired Remote Controller

2.2.1 LCD Wired Remote Controller KJR-12B/DP(T) (Optional)

The KJR-12B/DP(T) wired remote controller is optional.

i) Buttons and Functions

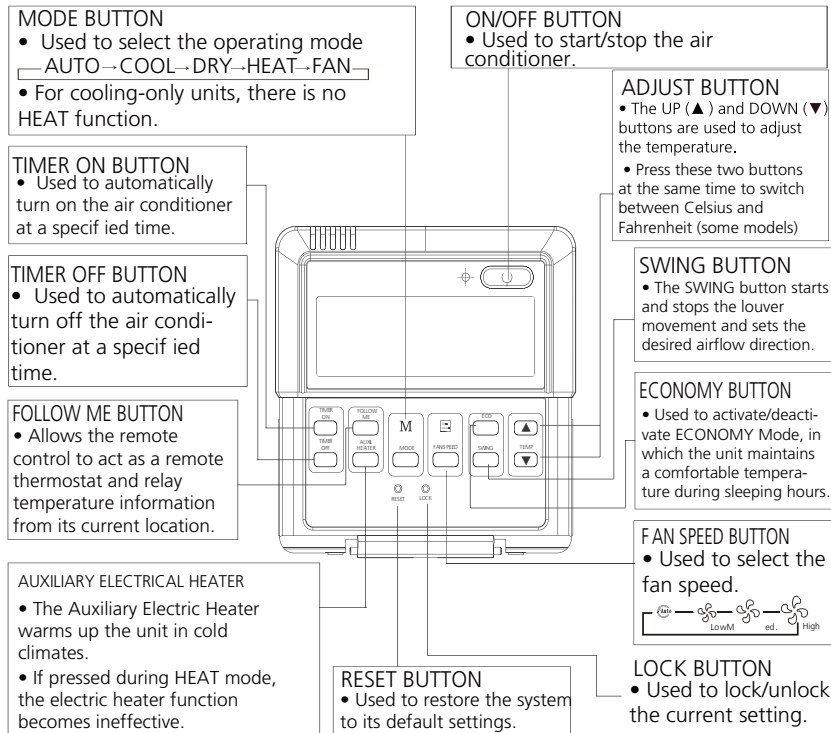

ii) LCD Screen

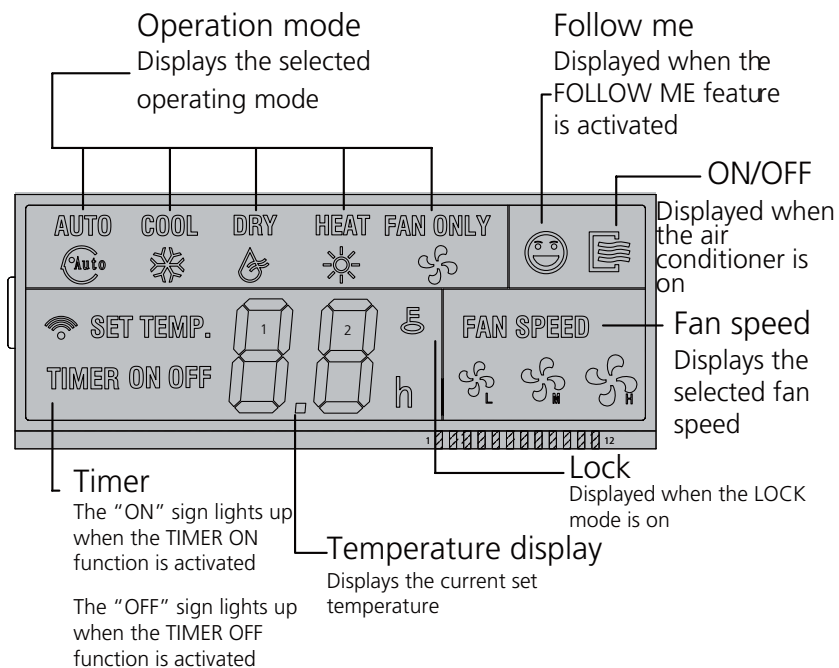

iii) Installation

- Dimensions

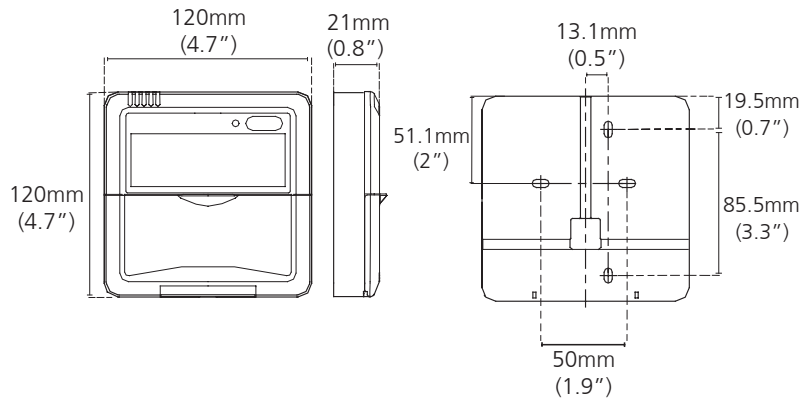

- Wiring diagram

Refer to the following diagram to wire the wall-mounted remote control to the indoor unit.

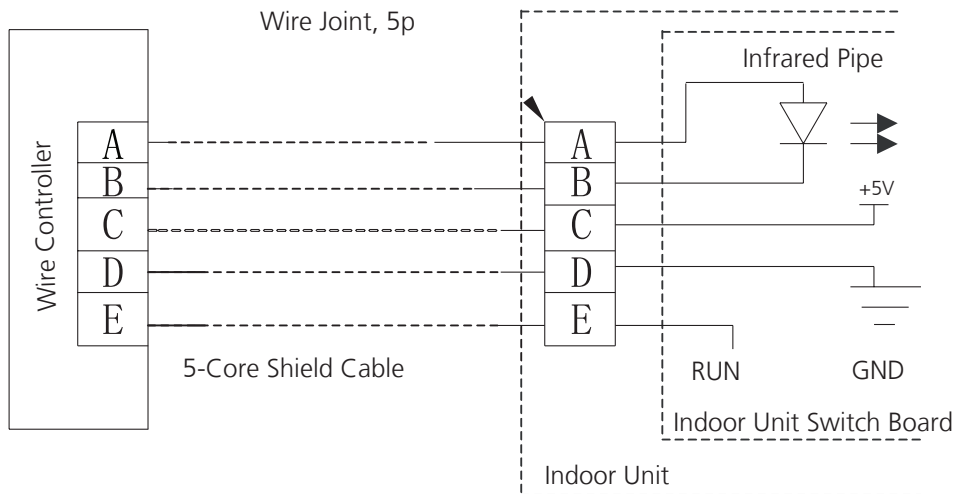

- Installation Diagram

Connect the wire from the display panel of the indoor unit to a connecting cable. Then connect the other side of the connecting cable to the remote control.

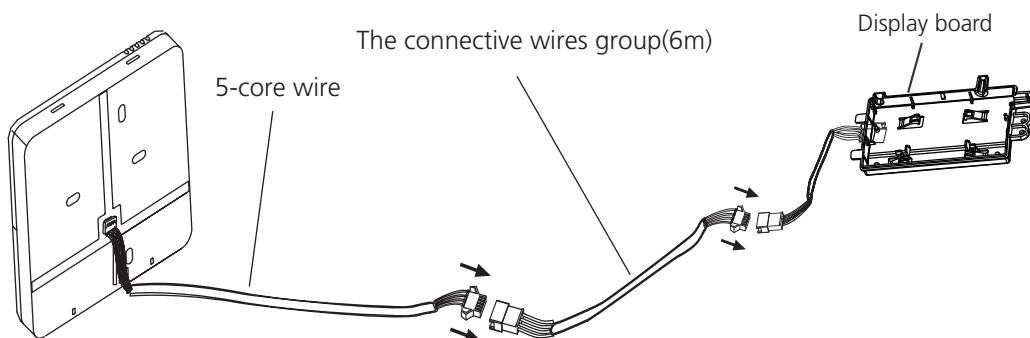

Note: Be sure to reserve a length of the connecting wire for periodic maintenance.

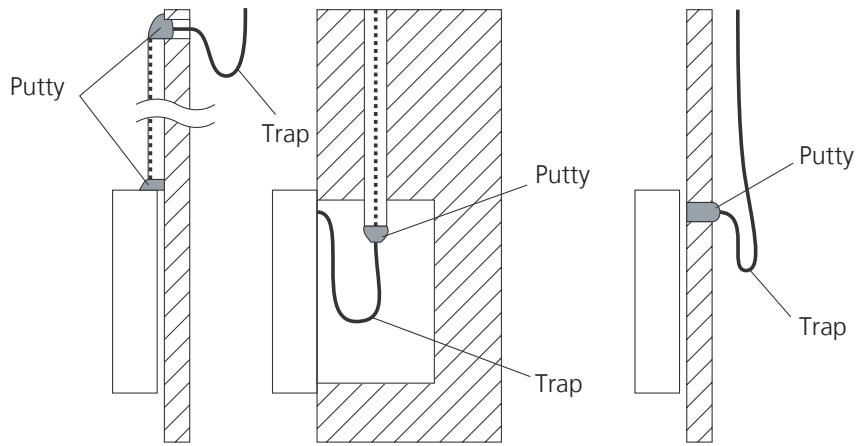

Note: DO NOT allow water to enter the remote control. Use the trap and putty to seal the wires.

- For exposed mounting, cut holes on four of the sides according to the picture below.

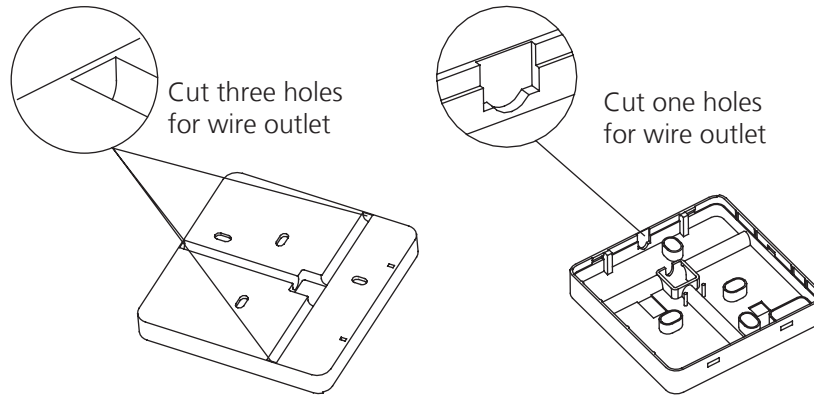

- For shielded wiring, please refer to the picture below.

Embedded switch box wiring

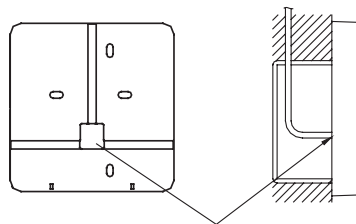

Wiring hole

Wiring through the wall

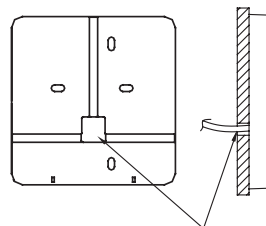

Wall hole and wiring hole
Diameter of wall hole: Φ 2cm

2.2.2 LCD Wired Remote Controller KJR-120C/TF-E(Optional)

The KJR-120C/TF-E wired remote controller is optional.

i) Buttons and Functions

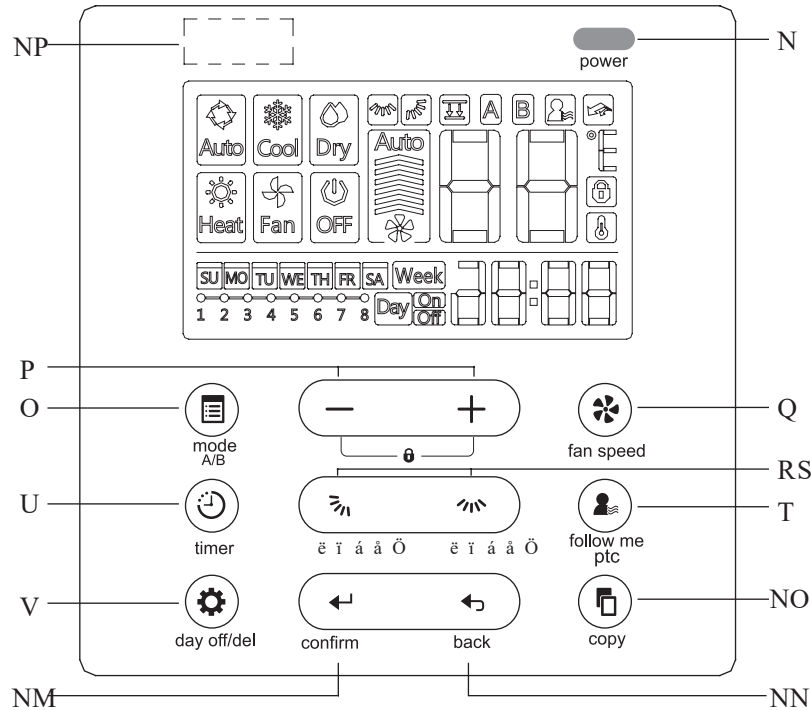

1. POWER button

Turn on or turn off the unit.

2. MODE(A/B) button

Used to select the operation mode: Auto / Cooling / Drying / Heating / Fan;

Hold to activate the operation of auto-lifting panel when off

3. Adjust button

To set temperature, time and timer; set up or down the auto-lifting panel

4. FAN SPEED button

Used to select the fan speed.

5. Up-down airflow direction and swing Button

Press for adjusting the angel of louver, hold for vertical swing; individual louver control for cassette panel

6. Left-right airflow swing Button

Press for activating the horizontal swing

7. FOLLOW ME(PTC) button

Allows the remote control to act as a remote thermostat and send temperature information from its current location.

8. TIMER button

To set timer on and timer off time of one day

9. DELAY/DAY OFF button

To set 1 to 2 hours delay off for each day or a whole day off in a weekly timer schedule

10. CONFIRM button

To confirm an setting or call up the menu

11. BACK button

Back to previous operation or superior menu

12. COPY button

Copy timer setting of one day to another in weekly schedule setting

13 Infrared remote receiver (on some models)

ii) LCD Screen

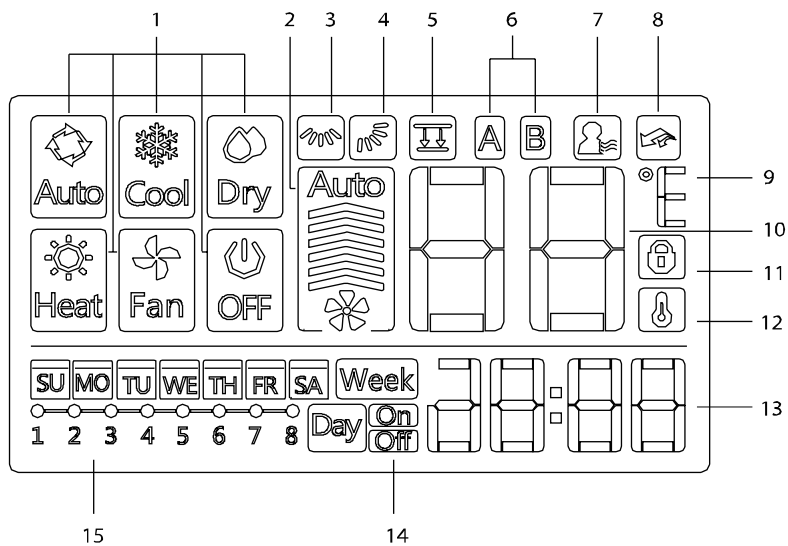

1 Operation mode indication

2 Fan speed indication

3 Left-right swing indication

4 Up-down swing indication

5 Faceplate function indication

6 Main unit and secondary unit indication

7 Follow me function indication

8 PTC function indication

9 C° / F° indication

10 Temperature display

11 Lock indication

12 Room temperature indication

13 Clock display

14 On/Off timer

15 Timer display

iii) Installation

- Dimensions

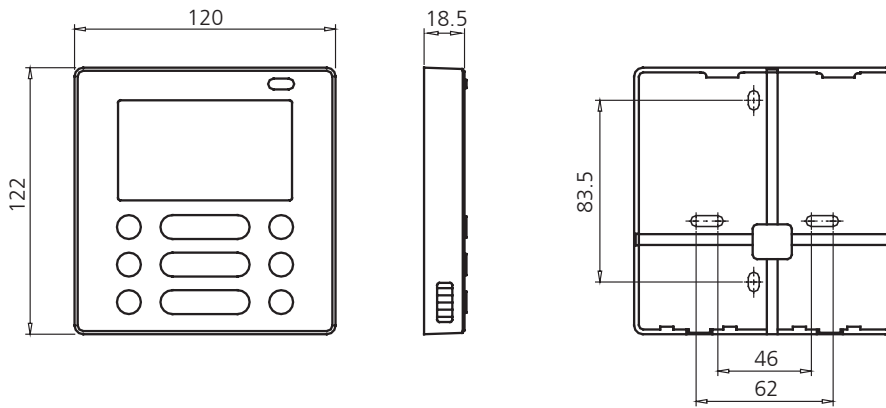

- Wiring diagram

Refer to the following diagram to wire the wall-mounted remote control to the indoor unit.

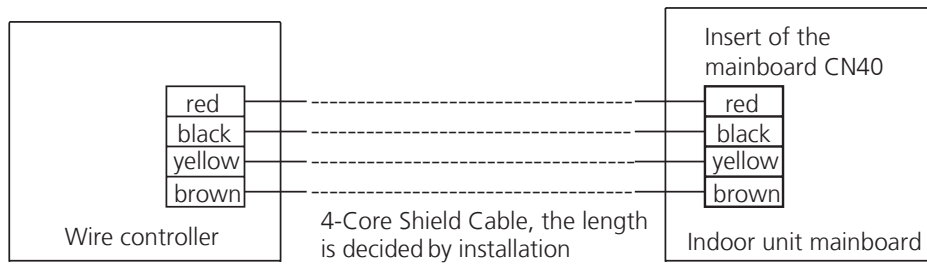

- Installation Diagram

Connect the female joint of wires group from the mainboard with the male joint of connective wires group. Then connect the other side of connective wires group with the male joint of wires group leads from wire controller.

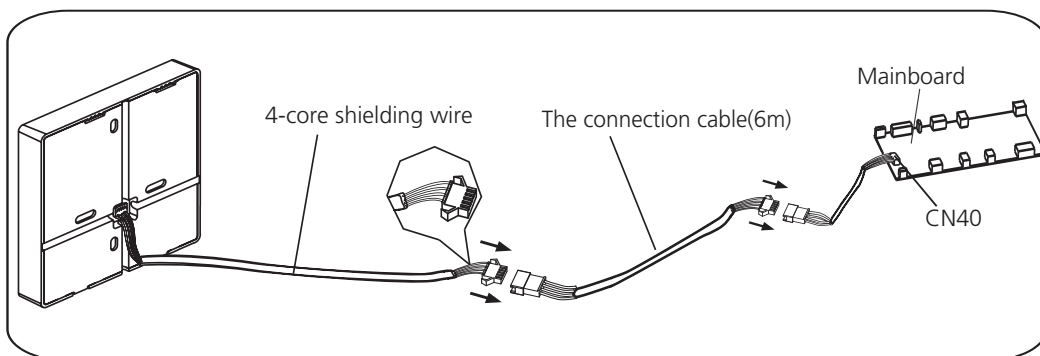

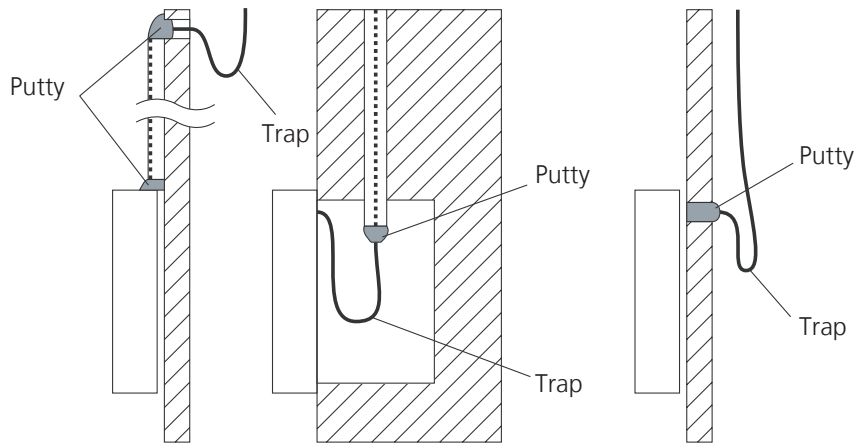

Note: DO NOT allow water to enter the remote control. Use the trap and putty to seal the wires.

- For exposed mounting, four outletting positions. There are three need cutting.

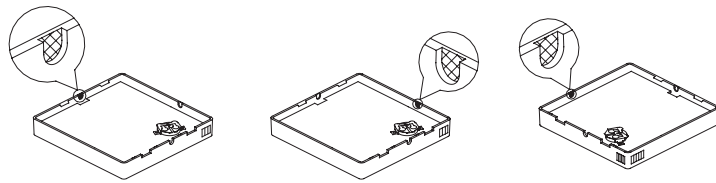

Cutting place of top side wire outlet

Cutting place of left side wire outlet

Cutting place of right side wire outlet

- For shielded wiring, please refer to the picture below.

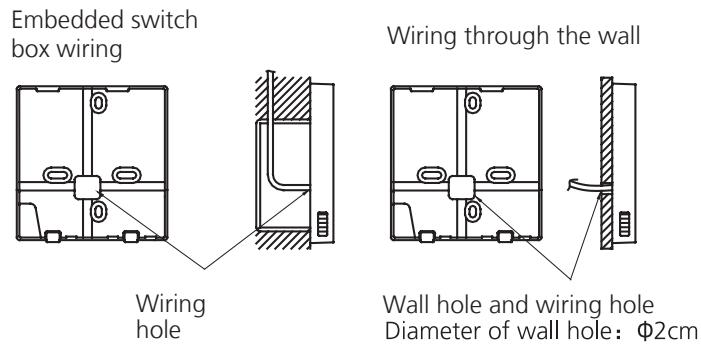

2.2.3 LCD Wired Remote Controller KJR-120G/TF-E(Optional)

The KJR-120G/TF-E wired remote controller is optional.

i) Buttons and Functions

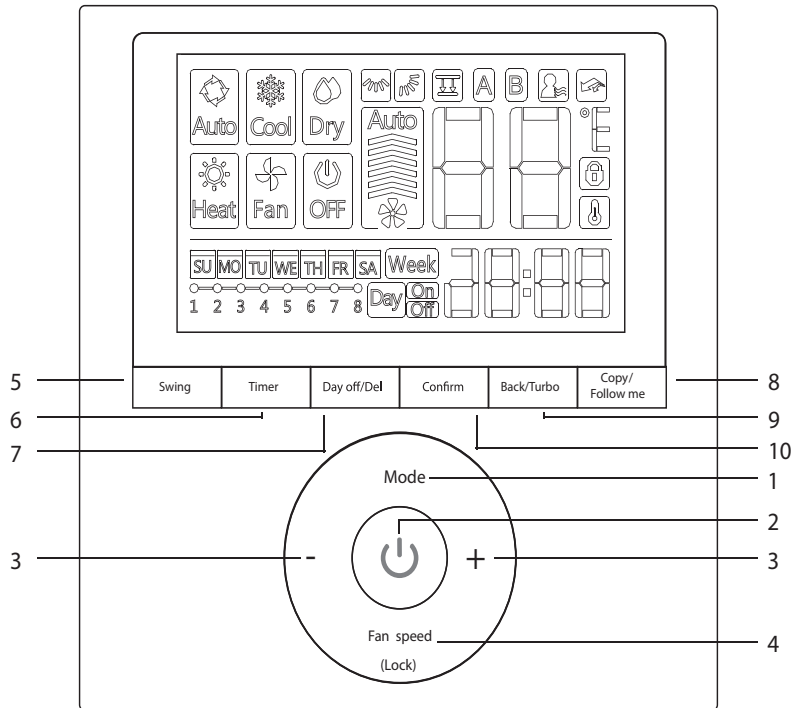

1. MODE button

Used to select the operation mode: Auto / Cooling / Drying / Heating / Fan;

Hold to active the operation of auto-lifting panel when off

2. POWER button

Turn on of turn off the unit.

3. Adjust button

To set temperature, time and timer; set up or down the auto-lifting panel

4. FAN SPEED button

Used to select the fan speed.

5. Swing Button

Press to active vertical swing, hold for horizontal swing

6. TIMER button

To set timer on and timer off time of one day

7. DELAY/DAY OFF button

To set 1 to 2 hours delay off for each day or a whole day off in a weekly timer schedule

8. COPY/FOLLOW ME button

To copy timer setting of one day to another in weekly schedule setting;

To active the follow me function while in normal operation.

9. BACK/TURBO button

Back to previous operation or superior menu

To active turbo mode while in normal operation

10. CONFIRM button

To confirm an setting or call up the superior menu

ii) LCD Screen

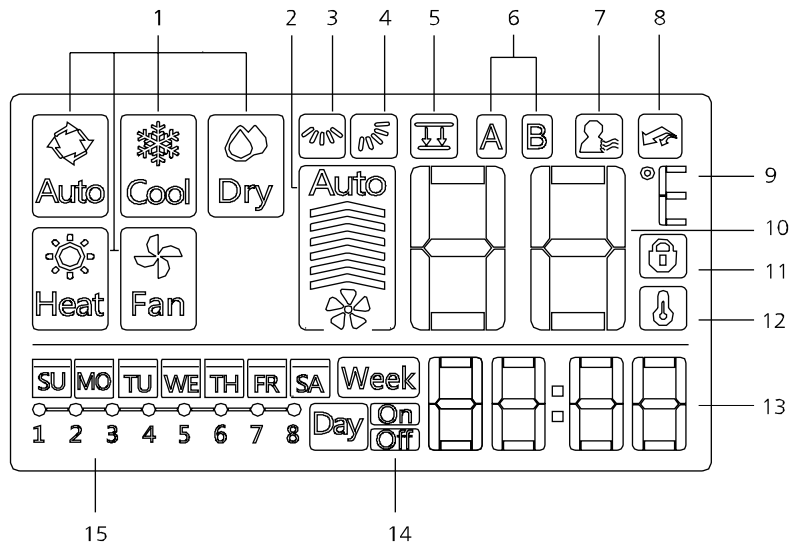

1 Operation mode indication

2 Fan speed indication

3 Left-right swing indication

4 Up-down swing indication

5 Faceplate function indication

6 Main unit and secondary unit indication

7 Follow me function indication

8 Turbo/PTC function indication

9 C° / F° indication

10 Temperature display

11 Lock indication

12 Room temperature indication

13 Clock display

14 On/Off timer

15 Timer display

iii) Installation

- Dimensions

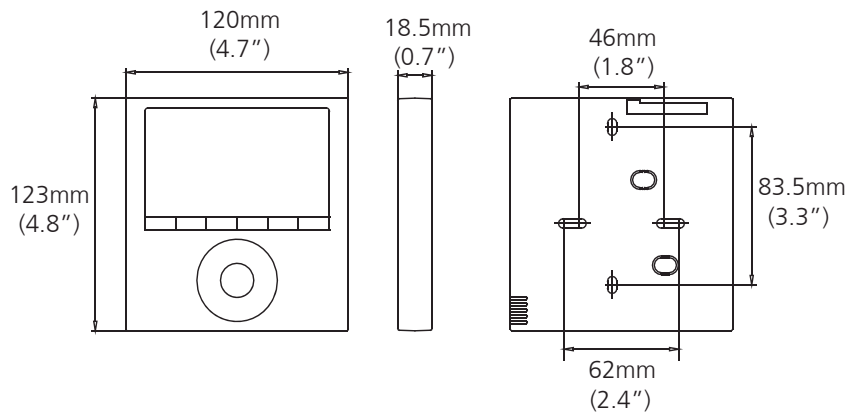

- Wiring diagram

3) Connection

For some models: The Remote Controller connects to main control board directly.

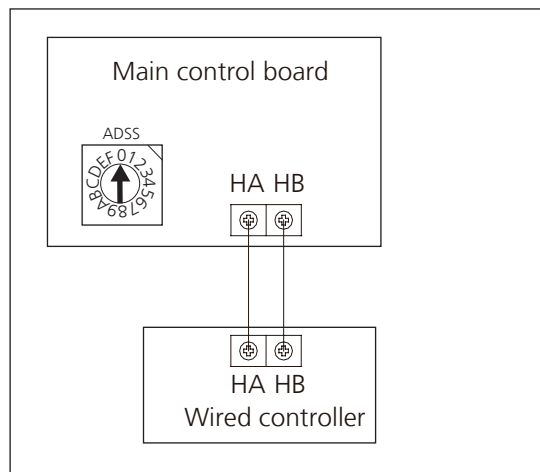

For some models: The Remote Controller connects to terminal board, terminal board connects to main control board.

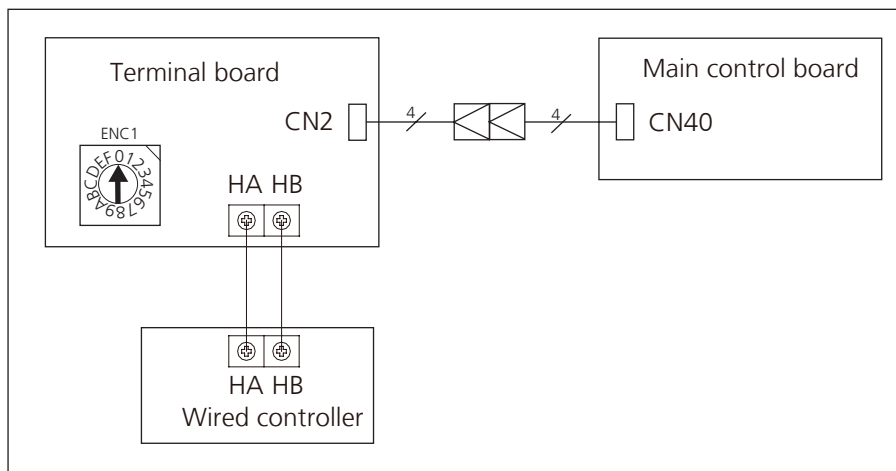

4) Address setting

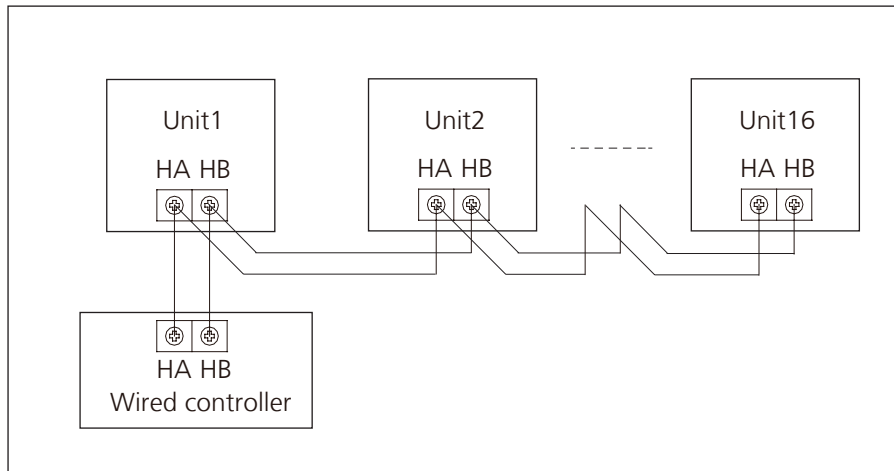

- One non-polarity controller can control up to 16 indoor units.
- When the non-polarity controller is connected to several units, every air-conditioner in network has only one network address to distinguish each other.
- Address code of air-conditioner in LAN is set by code switch ENC1(Duct and Ceiling& Floor) or ADSS(Cassette) of the indoor unit, and the set range is 0-15.
- Note: The indoor units are controlled at the same time, not independently. The purpose of setting network address is identify the unit when error occurs.

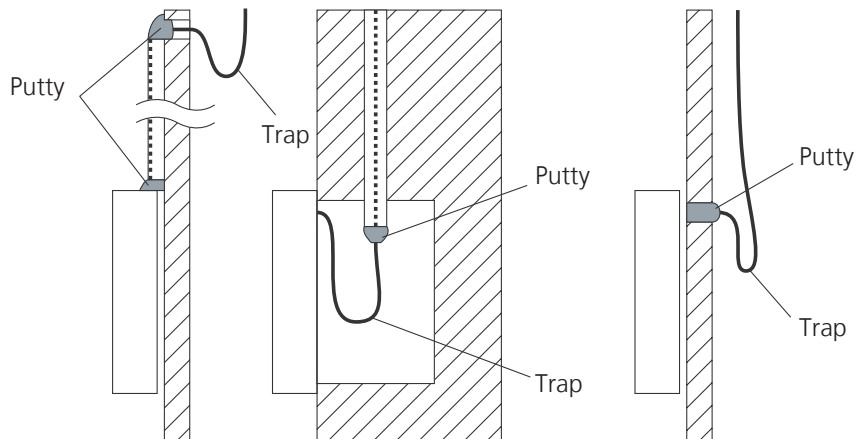

Note: DO NOT allow water to enter the remote control. Use the trap and putty to seal the wires.

• **For wiring the indoor unit, there are three methods:**

- From the rear;
- From the bottom;
- From the top;
- From the top center.

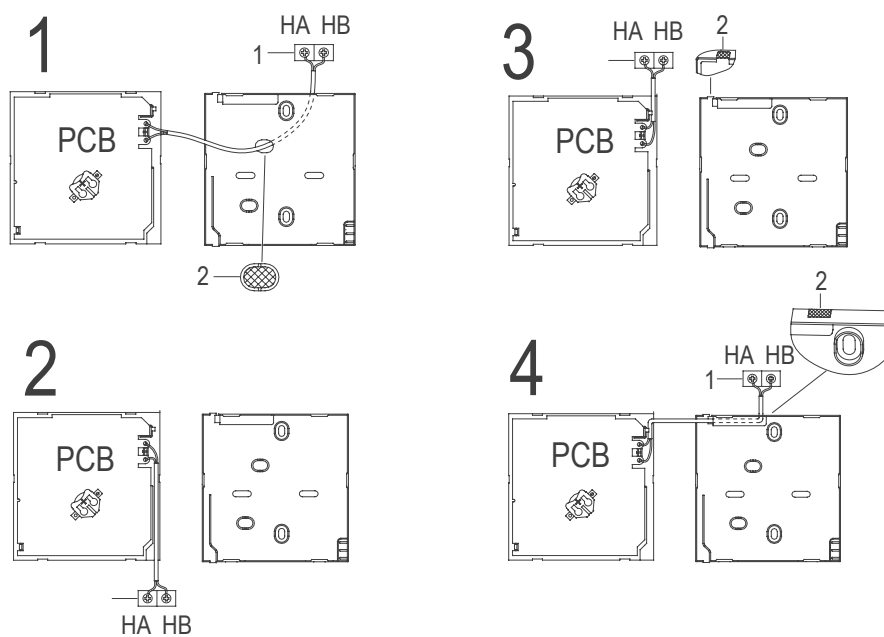

- 1: Indoor Unit.
- 2: Notch the part for the wiring to pass through with a nipper tool.
- Connect the terminals on the remote controller (HA ,HB), and the terminals of the indoor unit. (HA ,HB). (HA and HB do not have polarity.)

2.2.4 LCD Wired Remote Controller KJR-120X/TFBG-E(Optional)

The KJR-120X/TFBG-E wired remote controller is optional.

i) Buttons and Functions

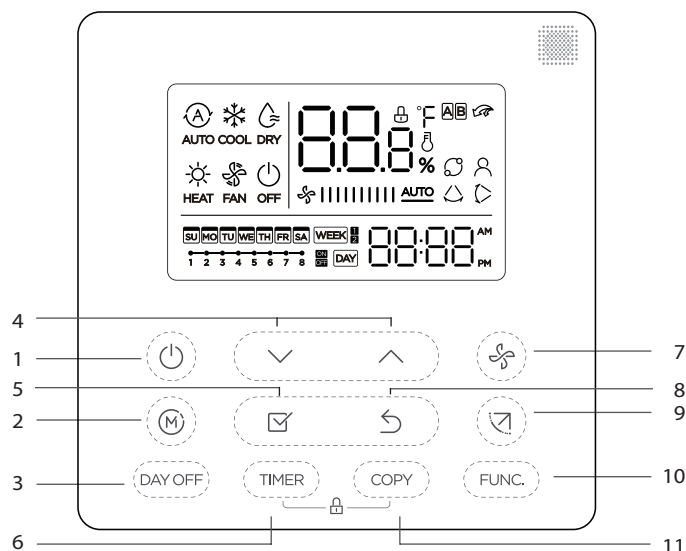

1. POWER button

Turn on or turn off the unit.

2. MODE button

Used to select the operation mode: Auto / Cooling / Drying / Heating / Fan;

3. DAY OFF/DEL button

To set 1 to 2 hours delay off for each day or a whole day off in a weekly timer schedule.

4. Adjust button

To set temperature, time and timer

5. CONFIRM button

To confirm an setting or call up the superior menu

6. TIMER button

To set timer on and timer off time of one day

7. FAN SPEED button

Used to select the fan speed.

8. BACK button

Back to previous operation or superior menu

9. SWING Button

Press to active vertical swing, hold for horizontal swing

10. FUNC. button

Press the FUNC. button to set the turbo or rotating or Ifeel function.

11. COPY button

To copy timer setting of one day to another in weekly schedule setting.

ii) LCD Screen

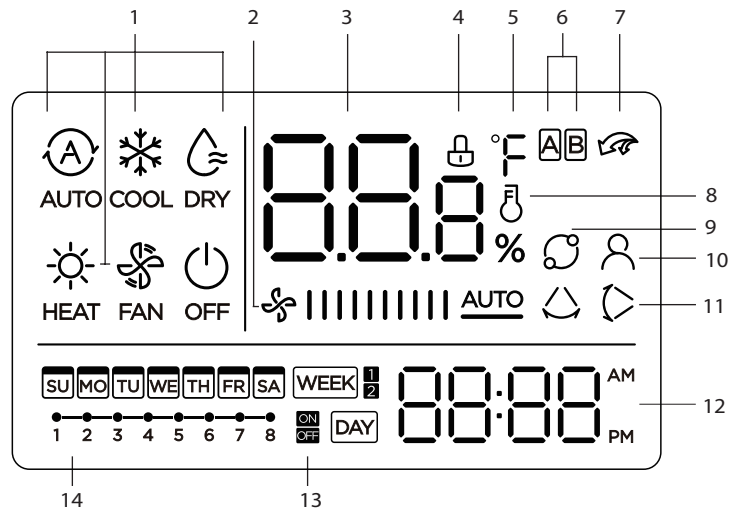

- 1 Operation mode indication
- 2 Fan speed indication
- 3 Temperature display
- 4 Lock indication
- 5 °C / °F indication
- 6 Main unit and secondary unit indication
- 7 Turbo function indication

- 8 Room temperature indication
- 9 Rotating indication
- 10 Follow Me function indication
- 11 Left-right swing indication
(some models)
- 12 Clock display
- 13 On/Of timer
- 14 Timer display

iii) Installation

• Dimensions

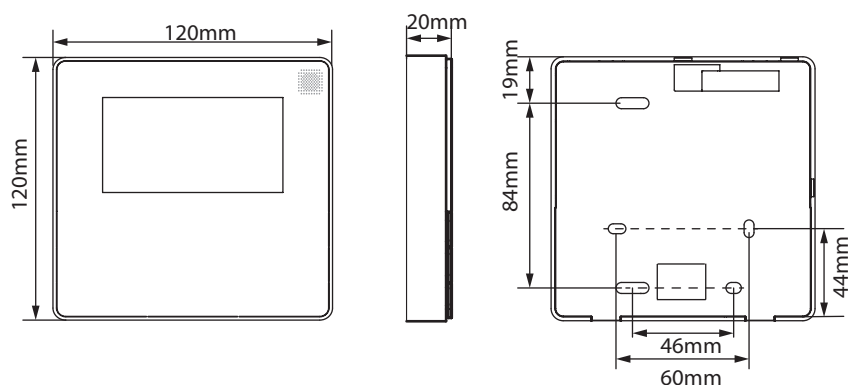

5) Connection

• Wire with the indoor unit:

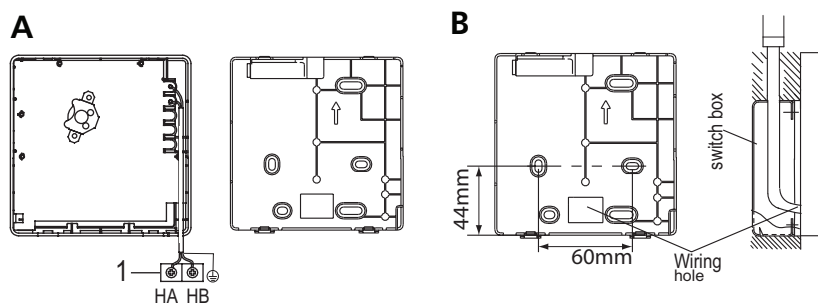

- 1: Indoor Unit.
- 2: Notch the part for the wiring to pass through with a nipper tool.
- Connect the terminals on the remote controller (HA ,HB), and the terminals of the indoor unit. (HA ,HB). (HA and HB do not have polarity.)

For some models: The wired controller connects to main control board directly.

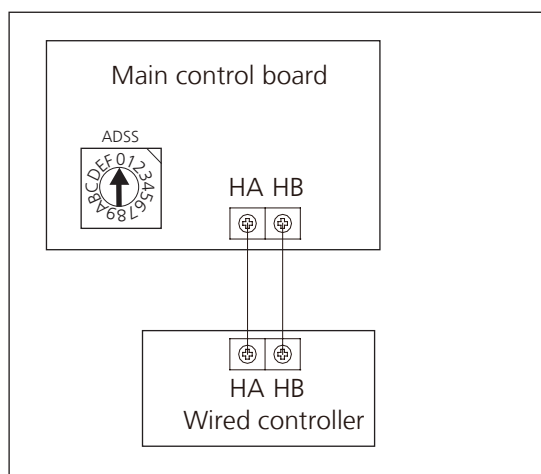

For some models: The wired controller connects to terminal board, terminal board connects to main control board.

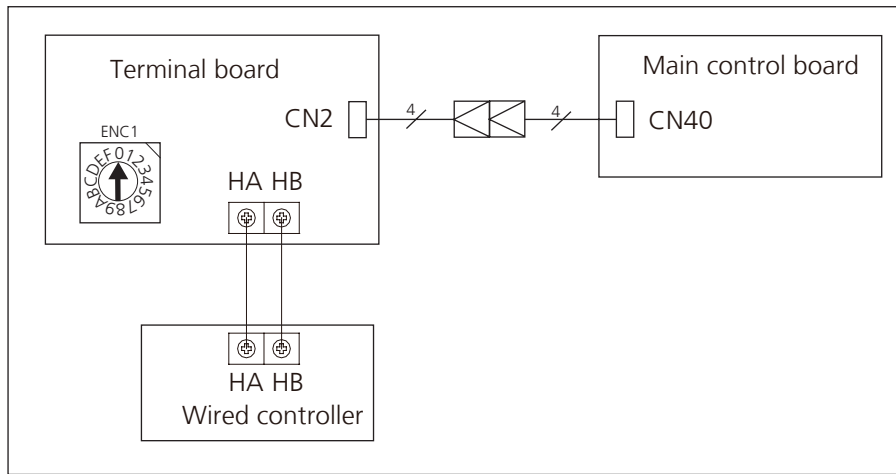

6) Address setting

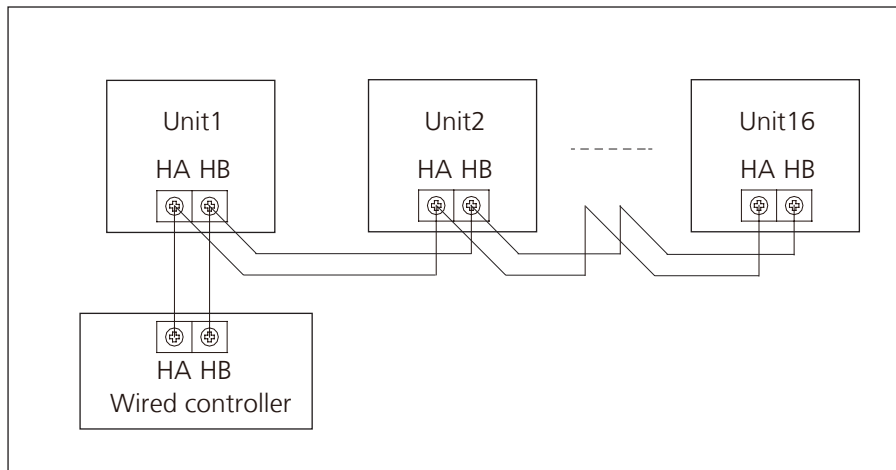

- One non-polarity controller can control up to 16 indoor units.
- When the non-polarity controller is connected to several units, every air-conditioner in network has only one network address to distinguish each other.
- Address code of air-conditioner in LAN is set by code switch ENC1(Duct and Ceiling& Floor) or ADSS(Cassette) of the indoor unit, and the set range is 0-15.
- Note: The indoor units are controlled at the same time, not independently. The purpose of setting network address is identify the unit when error occurs.

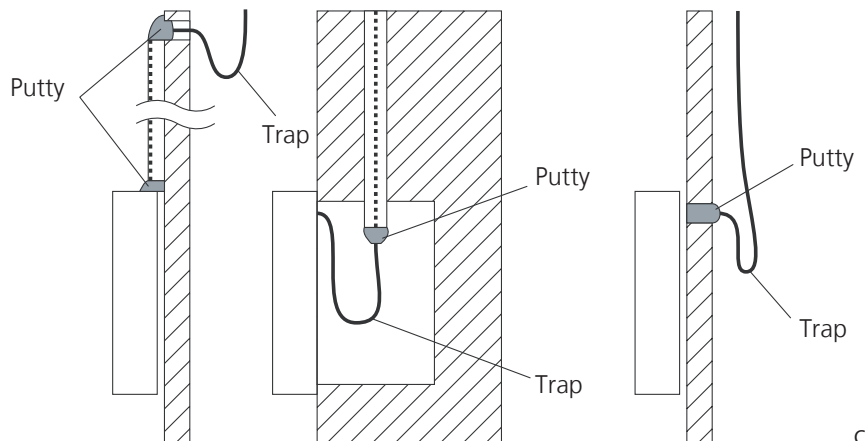

Note: DO NOT allow water to enter the remote control. Use the trap and putty to seal the wires.

2.3 Centralized Controller

1) Connection

For Light commercial air conditioner with XYE port, it can be directly connected to Centralized Controller (CCM03, CCM09).

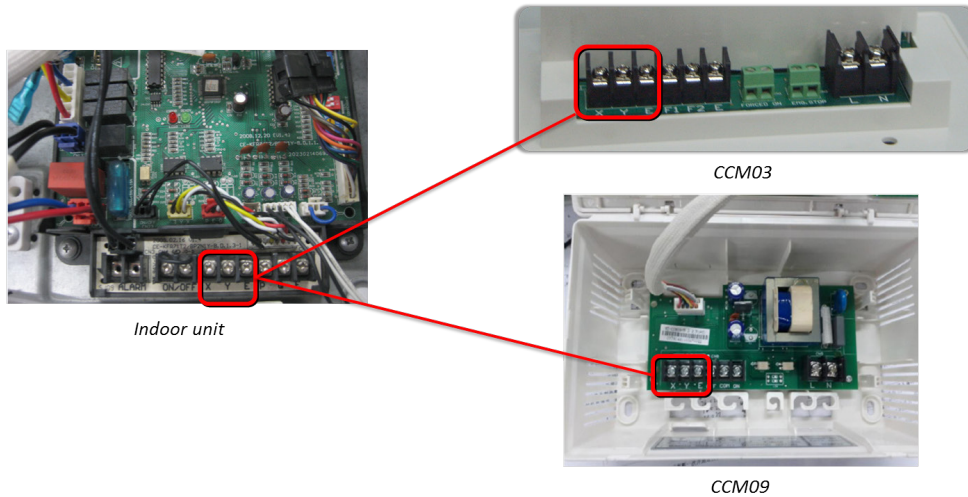

2) Address setting

When setting the address, please make sure the unit is powered off. The address can be set from 0 to 63 by the switch. Turn on the unit, then the address will be effective.

SWITCH		FOR CCM UNIT ADDRESS	
S2 + S1			
ADDRESS	0~15	16~31	
Factory Setting	✓		
S2 + S1			
ADDRESS	32~47	48~63	
Factory Setting			

Note: For light commercial air conditioner with XYE port, it can be also connected to BMS (Building Management System).











If there is any CAC (central air conditioner) connecting with the central controller at the same time, please set the address from largest (63,62,61...), since the CAC units could obtain address automatically from the smallest (00,01,02...)

Installation

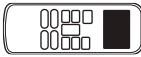
Contents

Accessories	111
1. Installation Overview	112
2. Location Selection	113
3. Indoor Unit Installation	114
4. Outdoor Unit Installation.....	116
5. Drainage Pipe Installation.....	118
6. Refrigerant Pipe Installation.....	119
7. Vacuum Drying and Leakage Checking.....	120
8. Additional Refrigerant Charge	121
9. Engineering of Insulation	121
10. Engineering of Electrical Wiring.....	122
11. Test Operation	123

Accessories

	Name	Shape	Quantity
Refrigeration Fittings	Soundproof/insulation sheath (some models)		1
Drainpipe Fittings	Outlet pipe sheath(some models)		1
	Outlet pipe clasp(some models)		1
	Drain joint (some models)		1
	Seal ring (some models)		1
Remote controller & Its Frame (some models)	Remote controller		1
	Fixing screw for remote controller holder ST2.9 x 10		2
	Remote controller holder		1
	Dry battery AAA		2
	Remote controller illustration		1
EMC Magnetic Ring (some models)	Magnetic ring (wrap the electric wires S1 & S2 (P & Q & E) around the magnetic ring twice)	 S1&S2(P&Q&E)	1
	Magnetic ring (Hitch it on the connective cable between indoor unit and outdoor unit after installation.)		1
	Manual		2~3

Optional accessories:

- There are two types of remote controls: wired and wireless.
- Select a remote controller based on customer preferences and requirements and install in an appropriate place.
- Refer to catalogues and technical literature for guidance on selecting a suitable remote controller.

1. Installation Overview

Installation Order

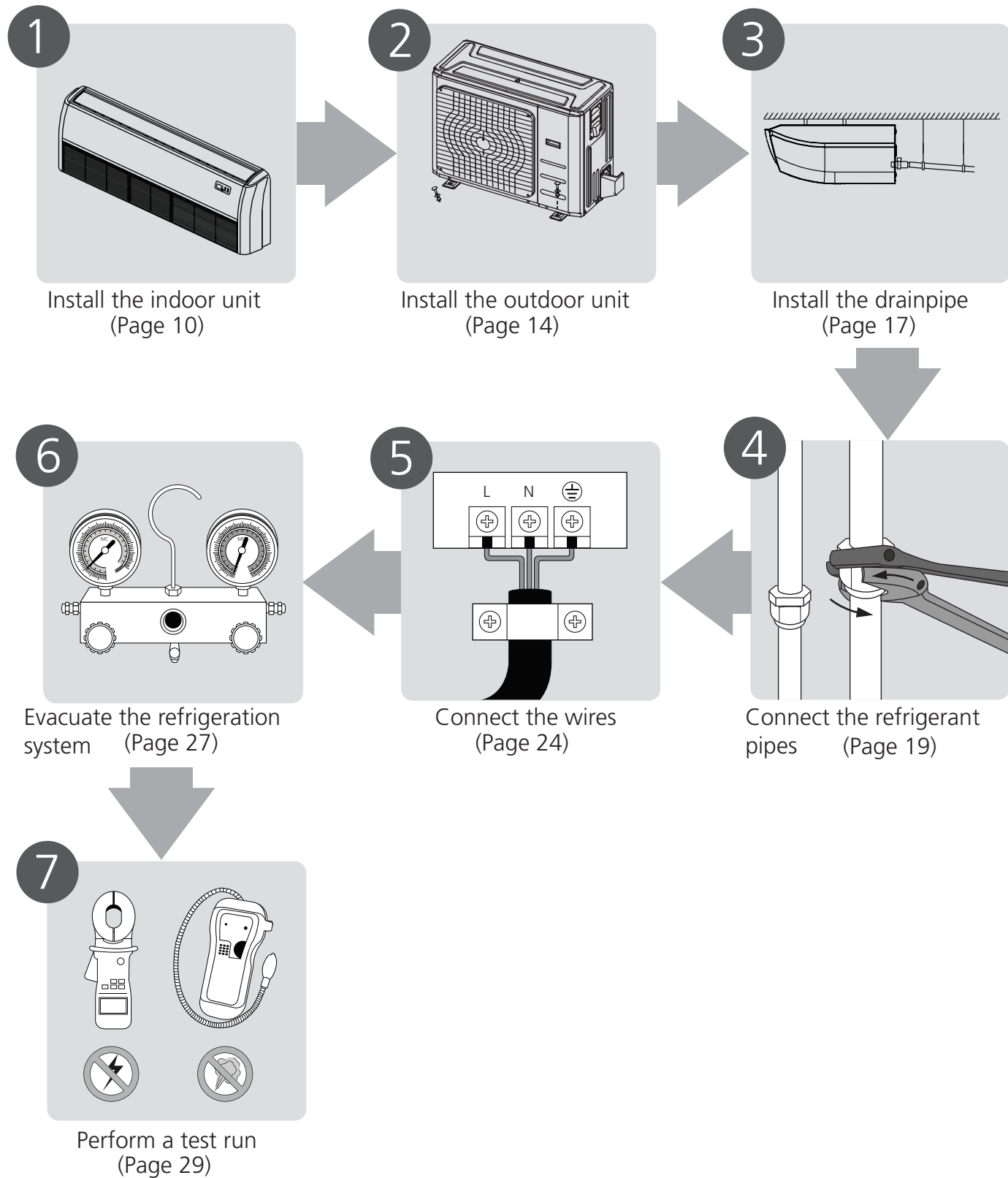

Installation

2. Location selection

2.1 Unit location selection can refer to installation manual.

2.2 **DO NOT** install the unit in the following locations:

- Where oil drilling or fracking is taking place.
- Coastal areas with high salt content in the air.
- Areas with caustic gases in the air, such as near hot springs.
- Areas with power fluctuations, such as factories.
- Enclosed spaces, such as cabinets.
- Areas with strong electromagnetic waves.
- Areas that store flammable materials or gas.
- Rooms with high humidity, such as bathrooms or laundry rooms.
- If possible, **DO NOT** install the unit where it is exposed to direct sunlight.

2.3 **The minimum distance between the outdoor unit and walls described in the installation guide does not apply to airtight rooms. Be sure to keep the unit unobstructed in at least two of the three directions (M, N, P)**

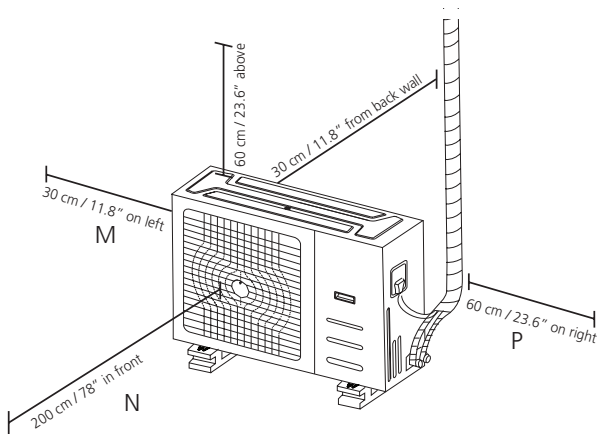

2.4 Rows of series installation

The relations between H, A and L are as follows.

	L	A
L ≤ H	$L \leq 1/2H$	25 cm / 9.8" or more
	$1/2H < L \leq H$	30 cm / 11.8" or more
L > H	Can not be installed	

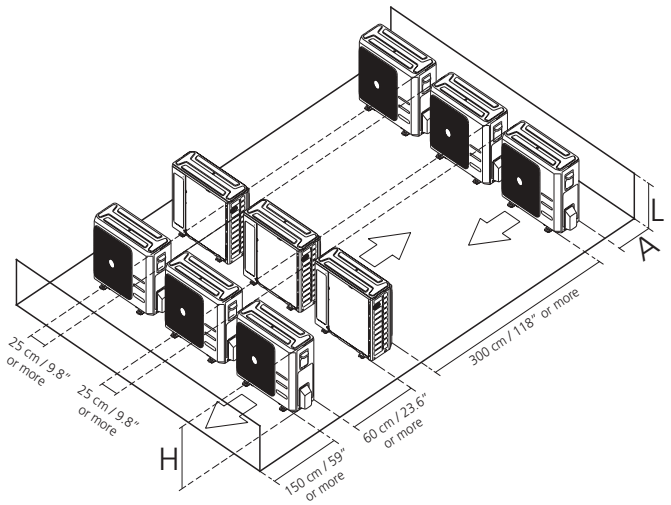

DO NOT install the rows of series like following figure.

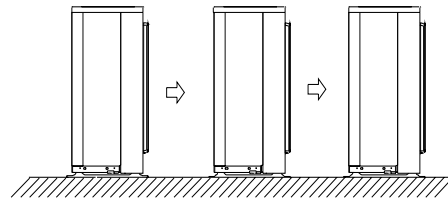

2.5 If the location is exposed to strong winds (for example: near a seaside), the unit must be placed against the wall to shelter it from the wind. If necessary, use an awning.

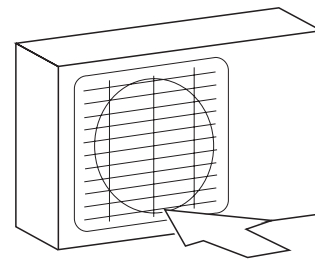

DO NOT Strong wind

3. Indoor Unit Installation

3.1 Service space for indoor unit

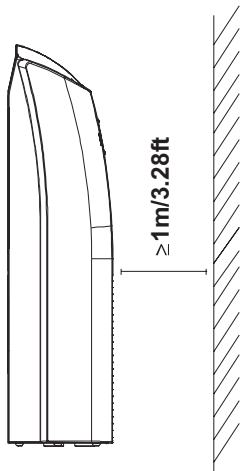
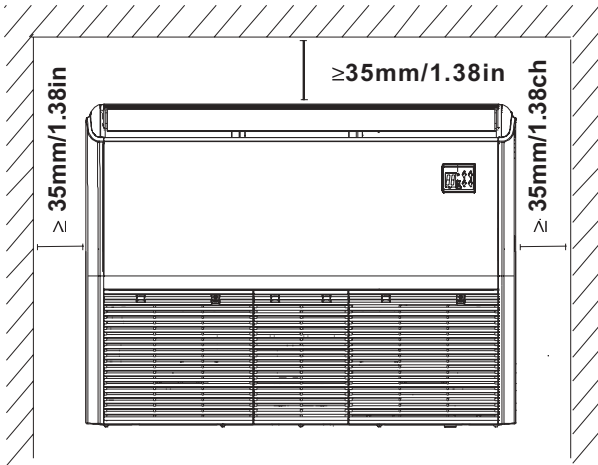

Wall-Mounted Installation

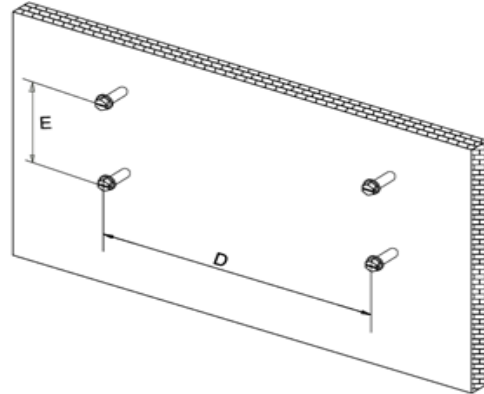

3.3 Hang Indoor Unit

- The installation of hanging screw bolts.
 - Cut off the roof beam.
 - Strengthen the area at which the cut was made and consolidate the roof beam.
- After the selection of the installation location, position the refrigerant pipes, drain pipes, and indoor and outdoor wires to the connection points before mounting the machine.
- Drill 4 holes 10cm (4") deep at the ceiling hook positions in the internal ceiling. Be sure to hold the drill at a 90° angle to the ceiling.
- Secure the bolt using the included washers and nuts.
- Install the four suspension bolts.
- Mount the indoor unit. You will need two people to lift and secure it. Insert suspension bolts into the unit's hanging holes. Fasten them using the included washers and nuts

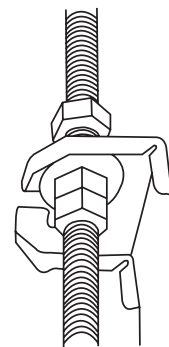

3.2 Bolt Pitch

Ceiling Installation

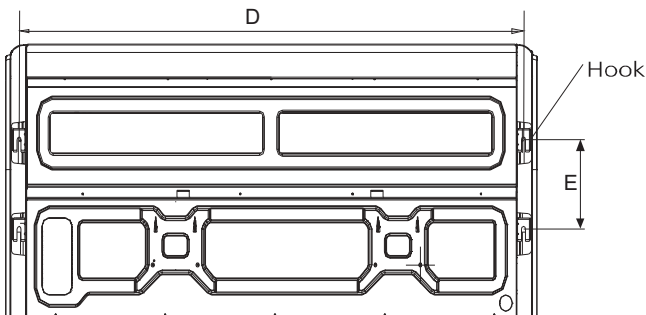

MODEL(kBtu/h)	Length of D (mm/inch)	Length of E (mm/inch)
24	983/38.7	220/8.7
36~60	1565/61.6	220/8.7

- Remove the side board and the grille.

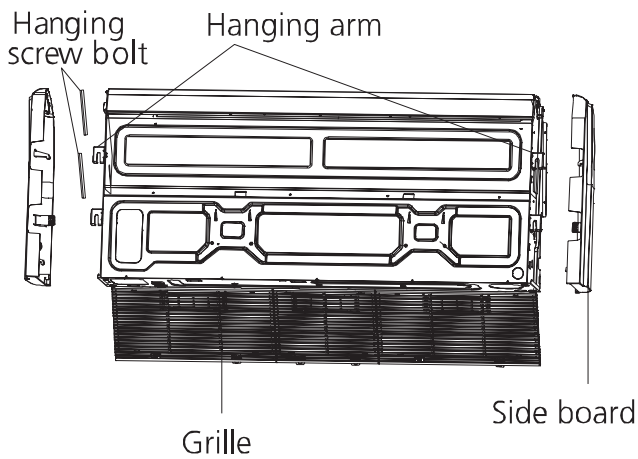

8. Mount the indoor unit onto the hanging screw bolts with a block.

Position the indoor unit on a flat level by using a level to prevent leaks.

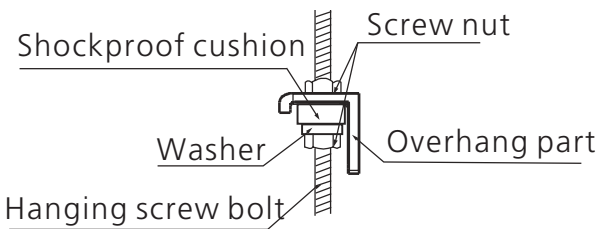

Note: Confirm the minimum drain tilt is 1/100 or more.

Ceiling Installation

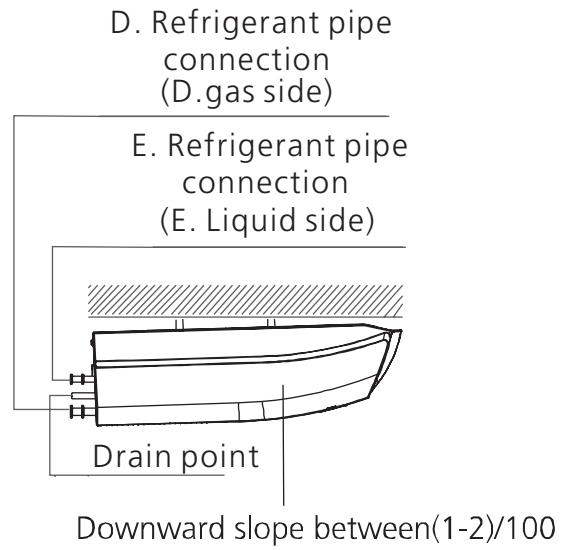
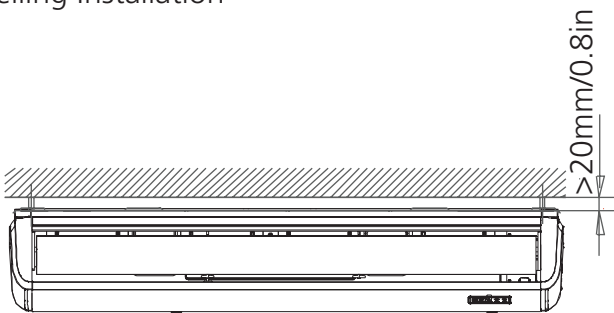

Wall-Mounted Installation

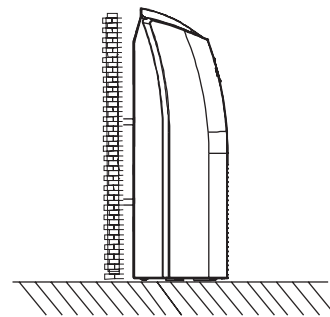

4. Outdoor unit installation(Side Discharge Unit)

4.1 Service space for outdoor unit

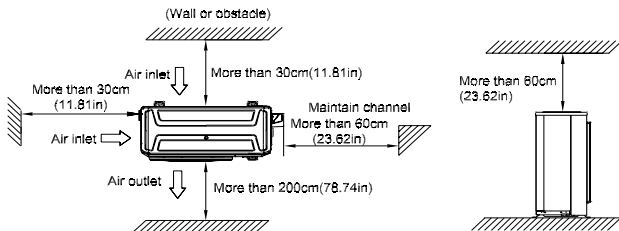

4.2 Bolt pitch

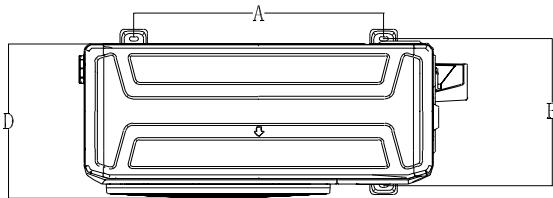

Capacity(kBtu/h)	A(mm)	B(mm)	D(mm)
24	663	354	342
36~48	673	403	410
55	634	404	415

4.3 Install Outdoor Unit

Fix the outdoor unit with anchor bolts(M10)

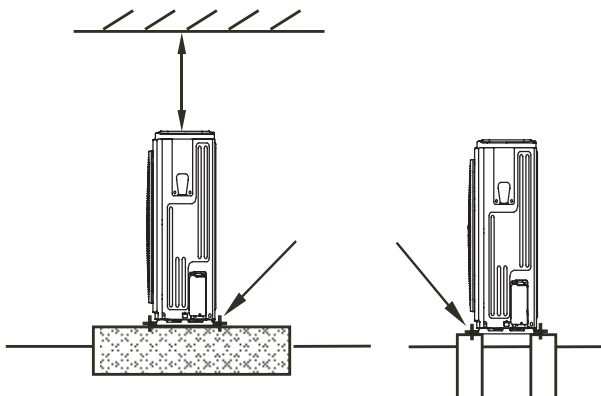

Cation

Since the gravity center of the unit is not at its physical center, so please be careful when lifting it with a sling.

Never hold the inlet of the outdoor unit to prevent it from

deforming.

Do not touch the fan with hands or other objects.

Do not lean it more than 45°, and do not lay it sidelong.

Make concrete foundation according to the specifications of the outdoor units.

Fasten the feet of this unit with bolts firmly to prevent it from collapsing in case of earthquake or strong wind.

5. Drainage Pipe Installation

Install the drainage pipe as shown below and take measures against condensation. Improperly installation could lead to leakage and eventually wet furniture and belongings.

5.1 Installation principle

- Ensure at least 1/100 slope of the drainage pipe
- Adopt suitable pipe diameter
- Adopt nearby condensate water discharge

5.2 Key points of drainage water pipe installation

1. Considering the pipeline route and elevation.
 - Before installing condensate water pipeline, determine its route and elevation to avoid intersection with other pipelines and ensure slope is straight.
2. Drainage pipe selection
 - The drainage pipe diameter shall not small than the drain hose of indoor unit
 - According to the water flowrate and drainage pipe slope to choose the suitable pipe, the water flowrate is decided by the capacity of indoor unit.

Relationship between water flowrate and capacity of indoor unit

Capacity (kBtu)	Water flowrate (l/h)
12	2.4
18	4
24	6
36	8
48	12
55	14

According to the above table to calculate the total water flowrate for the confluence pipe selection.

For horizontal drainage pipe (The following table is for reference)

PVC pipe	Reference value of inner diameter of pipe (mm)	Allowable maximum water flowrate (l/h)		Remark
		Slope 1/50	Slope 1/100	
PVC25	20	39	27	For branch pipe
PVC32	25	70	50	
PVC40	31	125	88	Could be used for confluence pipe
PVC50	40	247	175	
PVC63	51	473	334	

Attention: Adopt PVC40 or bigger pipe to be the main pipe.

For Vertical drainage pipe (The following table is for reference)

PVC pipe	Reference value of inner diameter of pipe (mm)	Allowable maximum water flowrate (l/h)	Remark
PVC25	20	220	For branch pipe
PVC32	25	410	
PVC40	31	730	Could be used for confluence pipe
PVC50	40	1440	
PVC63	51	2760	
PVC75	67	5710	
PVC90	77	8280	

Attention: Adopt PVC40 or bigger pipe to be the main pipe.

3. Individual design of drainage pipe system
 - The drainage pipe of air conditioner shall be installed separately with other sewage pipe, rainwater pipe and drainage pipe in building.
 - The drainage pipe of the indoor unit with water pump should be apart from the one without water pump.
4. Supporter gap of drainage pipe
 - In general, the supporter gap of the drainage pipe horizontal pipe and vertical pipe is respectively 1m~1.5m and 1.5m~2.0m.
 - Each vertical pipe shall be equipped with not less than two hangers.
 - Overlarge hanger gap for horizontal pipe shall create bending, thus leading to air block.

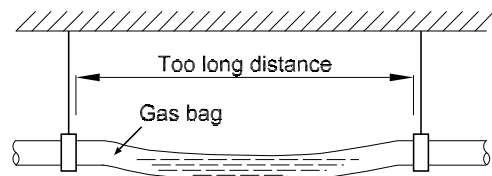

5. The horizontal pipe layout should avoid converse flow or bad flow

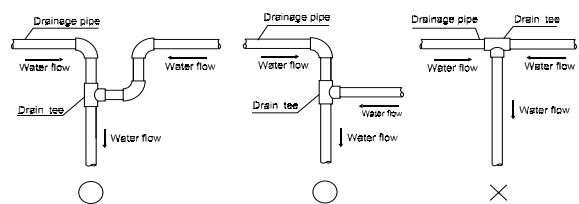

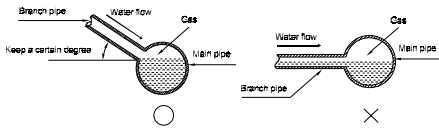

- The correct installation will not cause converse water flow and the slope of the branch pipes can be adjusted freely
- The false installation will cause converse water flow and the slope of the branch pipe can not be adjusted.

6. Water storage pipe setting

- If the indoor unit has high extra static pressure and without water pump to elevate the condensate water, such as high extra static pressure duct unit, the water storage pipe should be set to avoid converse flow or blow water phenomena.

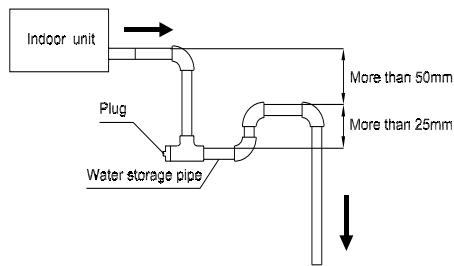

7. Lifting pipe setting of indoor unit with water pump

- The length of lifting pipe should not exceed 750mm.
- The drainage pipe should be set down inclined after the lifting pipe immediately to avoid wrong operation of water level switch.
- Refer the following picture for installation reference.

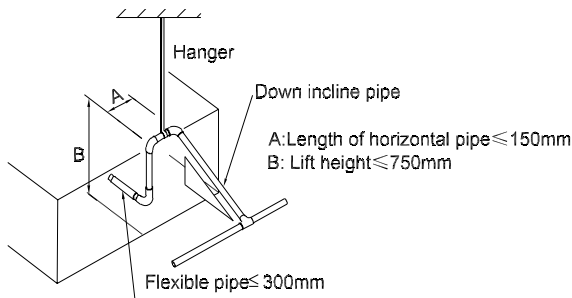

8. Blowhole setting

- For the concentrated drainage pipe system, there should design a blowhole at the highest point of main pipe to ensure the condensate water discharge smoothly.
- The air outlet shall face down to prevent dirt enter-

ing pipe.

- Each indoor unit of the system should be installed it.
- The installation should be considering the convenience for future cleaning.

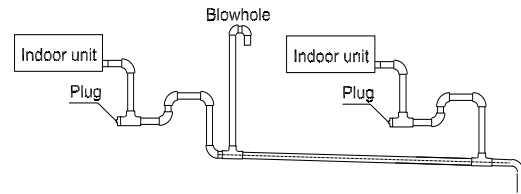

- 9. The end of drainage pipe shall not contact with ground directly.

5.3 Insulation work of drainage pipe

Refer the introduction to the insulation engineering parts.

6. Refrigerant Pipe Installation

6.1 Maximum length and drop height

Ensure that the length of the refrigerant pipe, the number of bends, and the drop height between the indoor and outdoor units meets the requirements shown in the following table.

Capacity(kBtu/h)	Max. Length (m/ft)	Max. Elevation (m/ft)
24	25/82	15/49.2
36	30/98.4	20/65.6
48~55	50/164	30/98.4

caution:

- The capacity test is based on the standard length and the maximum permissible length is based on the system reliability.
- Oil traps

-If oil flows back into the outdoor unit's compressor, this might cause liquid compression or deterioration of oil return. Oil traps in the rising gas piping can prevent this.

-An oil trap should be installed every 6m(20ft) of vertical suction line riser (<36000Btu/h unit).

-An oil trap should be installed every 10m(32.8ft) of vertical suction line riser (≥36000Btu/h unit).

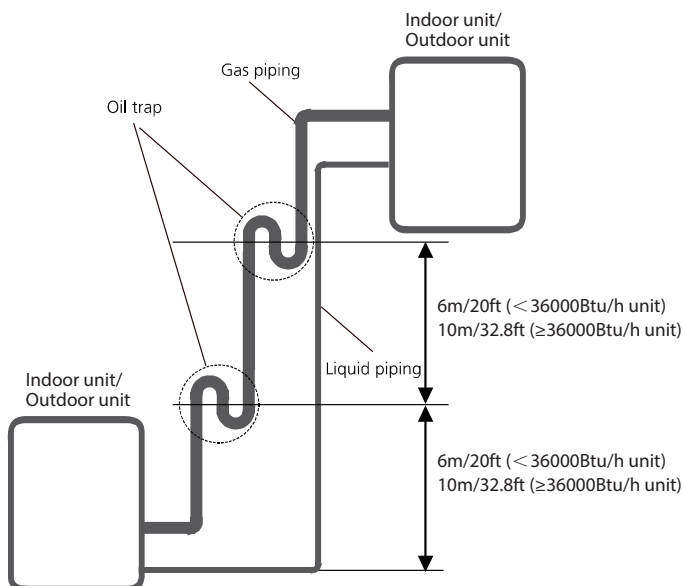

6.2 The procedure of connecting pipes

1. Choose the pipe size according to the specification table.
2. Confirm the cross way of the pipes.

3. Measure the necessary pipe length.

4. Cut the selected pipe with pipe cutter

- Make the section flat and smooth.

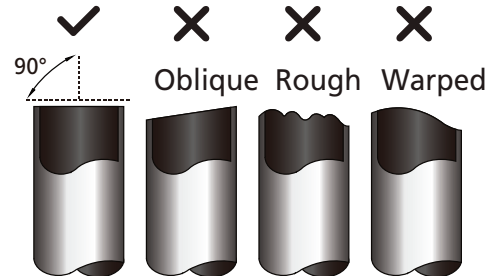

5. Insulate the copper pipe

- Before test operation, the joint parts should not be heat insulated.

6. Flare the pipe

- Insert a flare nut into the pipe before flaring the pipe
- According to the following table to flare the pipe.

Pipe diameter (inch(mm))	Flare dimension A (mm/inch)		Flare shape
	Min	Max	
1/4" (6.35)	8.4/0.33	8.7/0.34	
3/8" (9.52)	13.2/0.52	13.5/0.53	
1/2" (12.7)	16.2/0.64	16.5/0.65	
5/8" (15.9)	19.2/0.76	19.7/0.78	
3/4" (19)	23.2/0.91	23.7/0.93	
7/8" (22)	26.4/1.04	26.9/1.06	

- After flared the pipe, the opening part must be seal by end cover or adhesive tape to avoid duct or exogenous impurity come into the pipe.

7. Drill holes if the pipes need to pass the wall.

8. According to the field condition to bend the pipes so that it can pass the wall smoothly.

9. Bind and wrap the wire together with the insulated pipe if necessary.

10. Set the wall conduit

11. Set the supporter for the pipe.

12. Locate the pipe and fix it by supporter

- For horizontal refrigerant pipe, the distance between supporters should not be exceed 1m.
- For vertical refrigerant pipe, the distance between supporters should not be exceed 1.5m.

13. Connect the pipe to indoor unit and outdoor unit by

using two spanners.

- Be sure to use two spanners and proper torque to fasten the nut, too large torque will damage the bellmouthing, and too small torque may cause leakage. Refer the following table for different pipe connection.

Pipe Diameter	Torque	Sketch map
	N.m(lb.ft)	
1/4" (6.35)	15~16 (11~11.8)	
3/8" (9.52)	25~26 (18.4~19.18)	
1/2" (12.7)	35~36 (25.8~26.55)	
5/8" (15.9)	45~47 (33.19~34.67)	
3/4" (19)	65~67 (47.94~49.42)	
7/8" (22)	75~85 (55.3~62.7)	

7. Vacuum Drying and Leakage Checking

7.1 Purpose of vacuum drying

- Eliminating moisture in system to prevent the phenomena of ice-blockage and copper oxidation. Ice-blockage shall cause abnormal operation of system, while copper oxide shall damage compressor.
- Eliminating the non-condensable gas (air) in system to prevent the components oxidizing, pressure fluctuation and bad heat exchange during the operation of system.

7.2 Selection of vacuum pump

- The ultimate vacuum degree of vacuum pump shall be -756mmHg or above.
- Precision of vacuum pump shall reach 0.02mmHg or above.

7.3 Operation procedure for vacuum drying

Due to different construction environment, two kinds of vacuum drying ways could be chosen, namely ordinary vacuum drying and special vacuum drying.

7.3.1 Ordinary vacuum drying

1. When conduct first vacuum drying, connect pressure

gauge to the infusing mouth of gas pipe and liquid pipe, and keep vacuum pump running for 1 hour (vacuum degree of vacuum pump shall be reached -755mmHg).

2. If the vacuum degree of vacuum pump could not reach -755mmHg after 1 hour of drying, it indicates that there is moisture or leakage in pipeline system and need to go on with drying for half an hour.

3. If the vacuum degree of vacuum pump still could not reach -755mmHg after 1.5 hours of drying, check whether there is leakage source.

4. Leakage test: After the vacuum degree reaches -755mmHg, stop vacuum drying and keep the pressure for 1 hour. If the indicator of vacuum gauge does not go up, it is qualified. If going up, it indicates that there is moisture or leak source.

7.3.2 Special vacuum drying

The special vacuum drying method shall be adopted when:

1. Finding moisture during flushing refrigerant pipe.
2. Conducting construction on rainy day, because rain water might penetrated into pipeline.
3. Construction period is long, and rain water might penetrated into pipeline.
4. Rain water might penetrate into pipeline during construction.

Procedures of special vacuum drying are as follows:

1. Vacuum drying for 1 hour.
2. Vacuum damage, filling nitrogen to reach 0.5Kgf/cm².

Because nitrogen is dry gas, vacuum damage could achieve the effect of vacuum drying, but this method could not achieve drying thoroughly when there is too much moisture. Therefore, special attention shall be drawn to prevent the entering of water and the formation of condensate water.

3. Vacuum drying again for half an hour.

If the pressure reached -755mmHg, start to pressure leakage test. If it cannot reached the value, repeat vacuum damage and vacuum drying again for 1 hour.

4. Leakage test: After the vacuum degree reaches -755mmHg, stop vacuum drying and keep the pressure for 1 hour. If the indicator of vacuum gauge does not go up, it is qualified. If going up, it indicates that there is moisture or leak source.

8. Additional Refrigerant Charge

- After the vacuum drying process is carried out, the additional refrigerant charge process need to be performed.
- The outdoor unit is factory charged with refrigerant. The additional refrigerant charge volume is decided by the diameter and length of the liquid pipe between indoor and outdoor unit. Refer the following formula to calculate the charge volume.

Diameter of liquid pipe (mm)	Formula
6.35	$V=15g/m \times (L-5)$
9.52	$V=30g/m \times (L-5)$

V: Additional refrigerant charge volume (g).

L : The length of the liquid pipe (m).

Note:

- Refrigerant may only be charged after performed the vacuum drying process.
- Always use gloves and glasses to protect your hands and eyes during the charge work.
- Use electronic scale or fluid infusion apparatus to weight refrigerant to be recharged. Be sure to avoid extra refrigerant charged, it may cause liquid hammer of the compressor or protections.
- Use supplementing flexible pipe to connect refrigerant cylinder, pressure gauge and outdoor unit. And The refrigerant should be charged in liquid state. Before recharging, The air in the flexible pipe and manifold gauge should be exhausted.
- After finished refrigerant recharge process, check whether there is refrigerant leakage at the connection joint part.(Using gas leakage detector or soap water to detect).

9. Engineering of Insulation

9.1 Insulation of refrigerant pipe

1. Operational procedure of refrigerant pipe insulation

Cut the suitable pipe → insulation (except joint section) → flare the pipe → piping layout and connection → vacuum drying → insulate the joint parts

2. Purpose of refrigerant pipe insulation

- During operation, temperature of gas pipe and liquid pipe shall be over-heating or over-cooling extremely. Therefore, it is necessary to carry out insulation; otherwise it shall debase the performance of unit and burn compressor.
- Gas pipe temperature is very low during cooling. If insulation is not enough, it shall form dew and cause leakage.
- Temperature of gas pipe is very high (generally 50-100 °C) during heating. Insulation work must be carried out to prevent hurt by carelessness touching.

3. Insulation material selection for refrigerant pipe

- The burning performance should over 120 °C
- According to the local law to choose insulation materials
- The thickness of insulation layer shall be above 10mm. If in hot or wet environment place, the layer of insulation should be thicker accordingly.

4. Installation highlights of insulation construction

- Gas pipe and liquid pipe shall be insulated separately, if the gas pipe and liquid pipe were insulated together; it will decrease the performance of air conditioner.

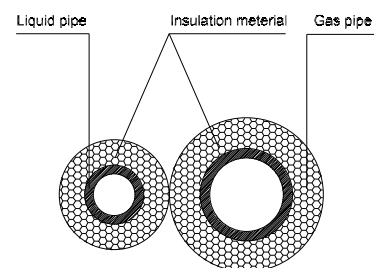

- The insulation material at the joint pipe shall be 5~10cm longer than the gap of the insulation material.
- The insulation material at the joint pipe shall be inserted into the gap of the insulation material.
- The insulation material at the joint pipe shall be banded to the gap pipe and liquid pipe tightly.
- The linking part should be use glue to paste together
- Be sure not bind the insulation material over-tight, it may extrude out the air in the material to cause bad

insulation and cause easy aging of the material.

9.2 Insulation of drainage pipe

1. Operational procedure of refrigerant pipe insulation

Select the suitable pipe → insulation (except joint section) → piping layout and connection → drainage test → insulate the joint parts

2. Purpose of drainage pipe insulation

The temperature of condensate drainage water is very low. If insulation is not enough, it shall form dew and cause leakage to damage the house decoration.

3. Insulation material selection for drainage pipe

- The insulation material should be flame retardant material, the flame retardancy of the material should be selected according to the local law.
- Thickness of insulation layer is usually above 10mm.
- Use specific glue to paste the seam of insulation material, and then bind with adhesive tape. The width of tape shall not be less than 5cm. Make sure it is firm and avoid dew.

4. Installation and highlights of insulation construction

- The single pipe should be insulated before connecting to another pipe, the joint part should be insulated after the drainage test.
- There should be no insulation gap between the insulation material.

10. Engineering of Electrical Wiring

10.1 Highlights of electrical wiring installation

- All field wiring construction should be finished by qualified electrician.
- Air conditioning equipment should be grounded according to the local electrical regulations.
- Current leakage protection switch should be installed.
- Do not connect the power wire to the terminal of signal wire.
- When power wire is parallel with signal wire, put wires to their own wire tube and remain at least 300mm gap.
- According to table in indoor part named “the specification of the power” to choose the wiring, make sure the selected wiring not small than the date showing in the table.
- Select different colors for different wire according to relevant regulations.
- Do not use metal wire tube at the place with acid or alkali corrosion, adopt plastic wire tube to replace it.
- There must be not wire connect joint in the wire tube If joint is a must, set a connection box at the place.
- The wiring with different voltage should not be in one wire tube.
- Ensure that the color of the wires of outdoor and the terminal No. are same as those of indoor unit respectively.
- You must first choose the right cable size before preparing it for connection. Be sure to use H07RN-F cables.

Table: Minimum Cross-Sectional Area able of Power and Signal Cables

Rated Current of Appliance (A)	Nominal Cross-Sectional Area(mm ²)
≤ 6	0.75
6 - 10	1
10 - 16	1.5
16 - 25	2.5
25 - 32	4
32 - 45	6

11. Test Operation

11.1 The test operation must be carried out after the entire installation has been completed.

11.2 Please confirm the following points before the test operation.

- The indoor unit and outdoor unit are installed properly.
- Tubing and wiring are correctly completed.
- The refrigerant pipe system is leakage-checked.
- The drainage is unimpeded.
- The ground wiring is connected correctly.
- The length of the tubing and the added stow capacity of the refrigerant have been recorded.
- The power voltage fits the rated voltage of the air conditioner.
- There is no obstacle at the outlet and inlet of the outdoor and indoor units.
- The gas-side and liquid-side stop valves are both opened.
- The air conditioner is pre-heated by turning on the power.

11.3 Test operation

1. Open both the liquid and gas stop valves.
2. Turn on the main power switch and allow the unit to warm up.
3. Set the air conditioner to COOL mode, and check the following points.

Indoor unit

- Whether the switch on the remote controller works well.
- Whether the buttons on the remote controller works well.
- Whether the air flow louver moves normally.
- Whether the room temperature is adjusted well.
- Whether the indicator lights normally.
- Whether the temporary buttons works well.
- Whether the drainage is normal.
- Whether there is vibration or abnormal noise during operation.

Outdoor unit

- Whether there is vibration or abnormal noise during operation.
- Whether the generated wind, noise, or condensed of by the air conditioner have influenced your neighborhood.
- Whether any of the refrigerant is leaked.

Drainage Test

- a. Ensure the drainpipe flows smoothly. New buildings should perform this test before finishing the ceiling.
- b. Remove the test cover. Add 2000ml of water to the tank through the attached tube.
- c. Turn on the main power switch and run the air conditioner in COOL mode.
- d. Listen to the sound of the drain pump to see if it makes any unusual noises.
- e. Check to see that the water is discharged. It may take up to one minute before the unit begins to drain depending on the drainpipe.
- f. Make sure that there are no leaks in any of the piping.
- g. Stop the air conditioner. Turn off the main power switch and reinstall the test cover.