

CONTENTS

1 External Appearance	3
2 Nomenclature	3
3 System Schematic	4
4 Specifications	5
5 BOM	7
6 Dimensions	9
7 Unit Installation	18
8 Application Examples	32
9 Pump Model Selection	45
10 Selection of Expansion Tank Volume and Preset Pressure	46
11 Final Check and Test Run	47
12 Piping Design	48
13 Wiring Diagram	49
14 Sound Levels	50
15 Accessories	52

1 External Appearance

Figure 1.1: Appearance



2 Nomenclature

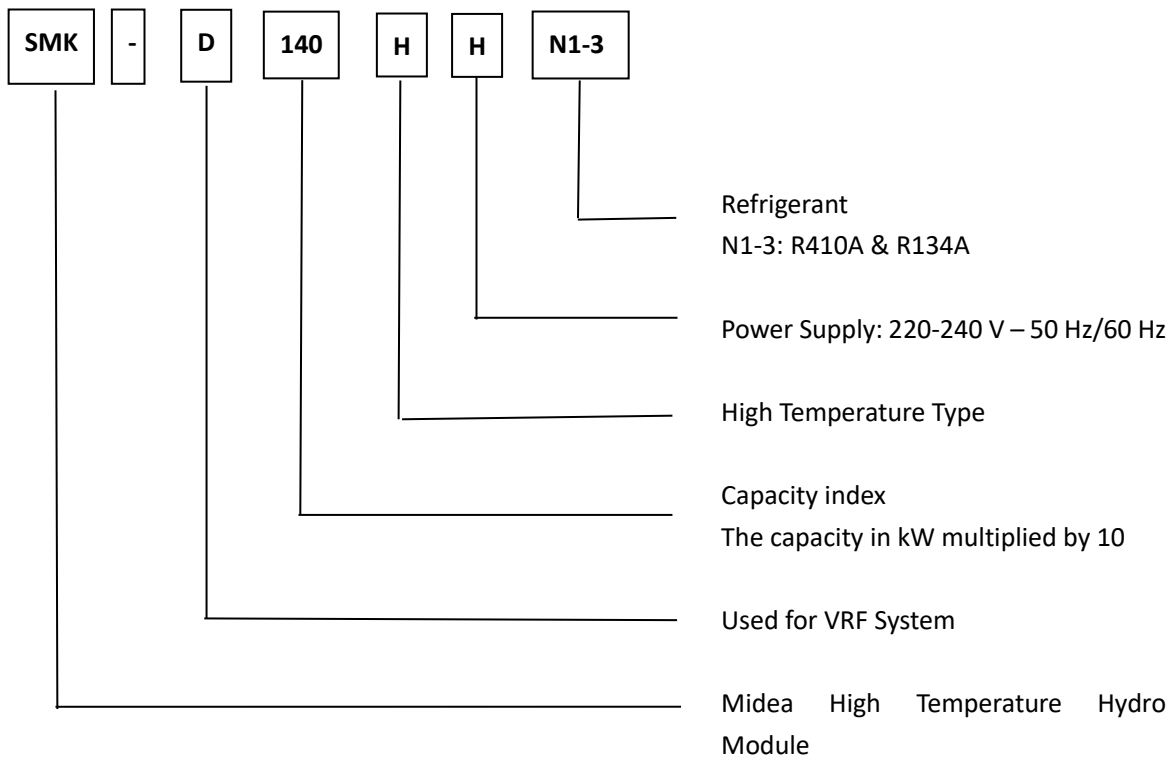

3 System Schematic

The following picture shows a schematic diagram using the High Temperature Hydro module and the VR system. The below picture shows a detailed schematic of the VR system using high temperature hydro module.

Figure 3.1: Hydro box connection method

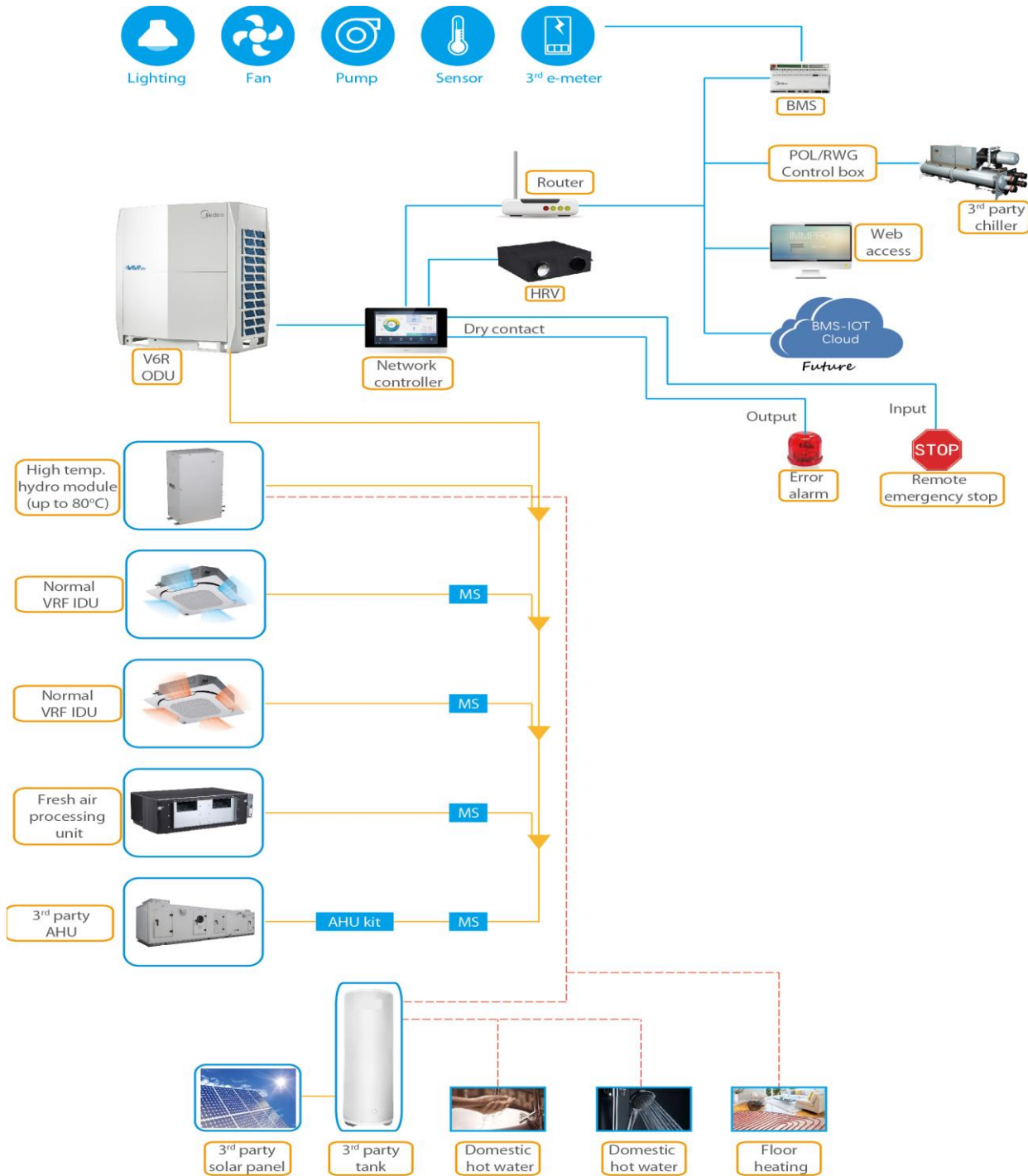

4 Specifications

Specification	Standard	Unit	Value
Heating capacity	Rated	kW	14
	Water outlet : 45°C, inlet 40°C		
	Outdoor air : 7°C DB / 6°C WB		
Casing	Colour		Polar white
Net Dimensions	Height	mm	795
	Width	mm	450
	Depth	mm	300
Packaging Dimensions	Height	mm	820
	Width	mm	735
	Depth	mm	380
Weight	Unit	kg	63
	Packed unit	kg	71
Water Flow Rate	Minimum	m ³ /h	1.2
	Nominal	m ³ /h	2.4
	Maximum	m ³ /h	2.9
Water circuit	Inlet piping connection diameter	mm	25.4
	Outlet piping connection diameter	mm	25.4
	Connection type		External screw thread
Design pressure	Allowed water pressure	Mpa	0.1~0.3
	R410a	Mpa	4
	R134a	Mpa	3.1
R134a refrigerant circuit	Refrigerant type		R-134a
	Refrigerant charged volume	kg	1.2
	Oil type		FV50S
	Oil charged volume	L	0.4
R410a refrigerant circuit	Gas piping connection diameter	mm	12.7
	Liquid piping connection diameter	mm	9.52
	Connection type		Welding
Sound pressure level	Nom.	dB (A)	43
Sound Power Level	Nom.	dB (A)	54
Heating Operation Range	Ambient, Min	°C	-20
	Ambient, Max	°C	30
	Water Side, Min	°C	25
	Water Side, Max	°C	80
Domestic Hot Water Operation Range	Ambient, Min	°C	-20
	Ambient, Max	°C	43
	Water Side, Min	°C	25
	Water Side, Max	°C	80

High Temperature Hydro Module



Specification	Standard	Unit	Value
Refrigerant side heat exchanger	Type		Plate heat exchanger
	Quantity		1
	Plate	Pieces	76
Water side heat exchanger	Type		Plate heat exchanger
	Quantity		1
	Plate	Pieces	38
Unit Location	Ambient, Min-Max	°C	0~40
Installation place			Indoor only
Power supply	Phase		1-ph
	Frequency	Hz	50/60
	Voltage	V	220 ~ 240
	Voltage Range, Min/Max	%	± 10
Current Amperes	Maximum running current (MCA)	A	16
	Recommended Fuse	A	20

Notes:

*Nominal heating conditions

Inlet water temperature: 40 °C

Water Flow Rate: 2.4 m³/h

Outdoor Temperature: 7°CDB/6°CWB

*The water circuit must use the closed circuit.

*Please do not use it as drinking water.

* Due to continuing improvement, the above specifications may be subject to change without notice.

* Please don't use the steel material for the water piping material.*

* Please always make water circulate or pull out the circulation water completely when not using it.

*Please do not use groundwater and well water.

5 BOM

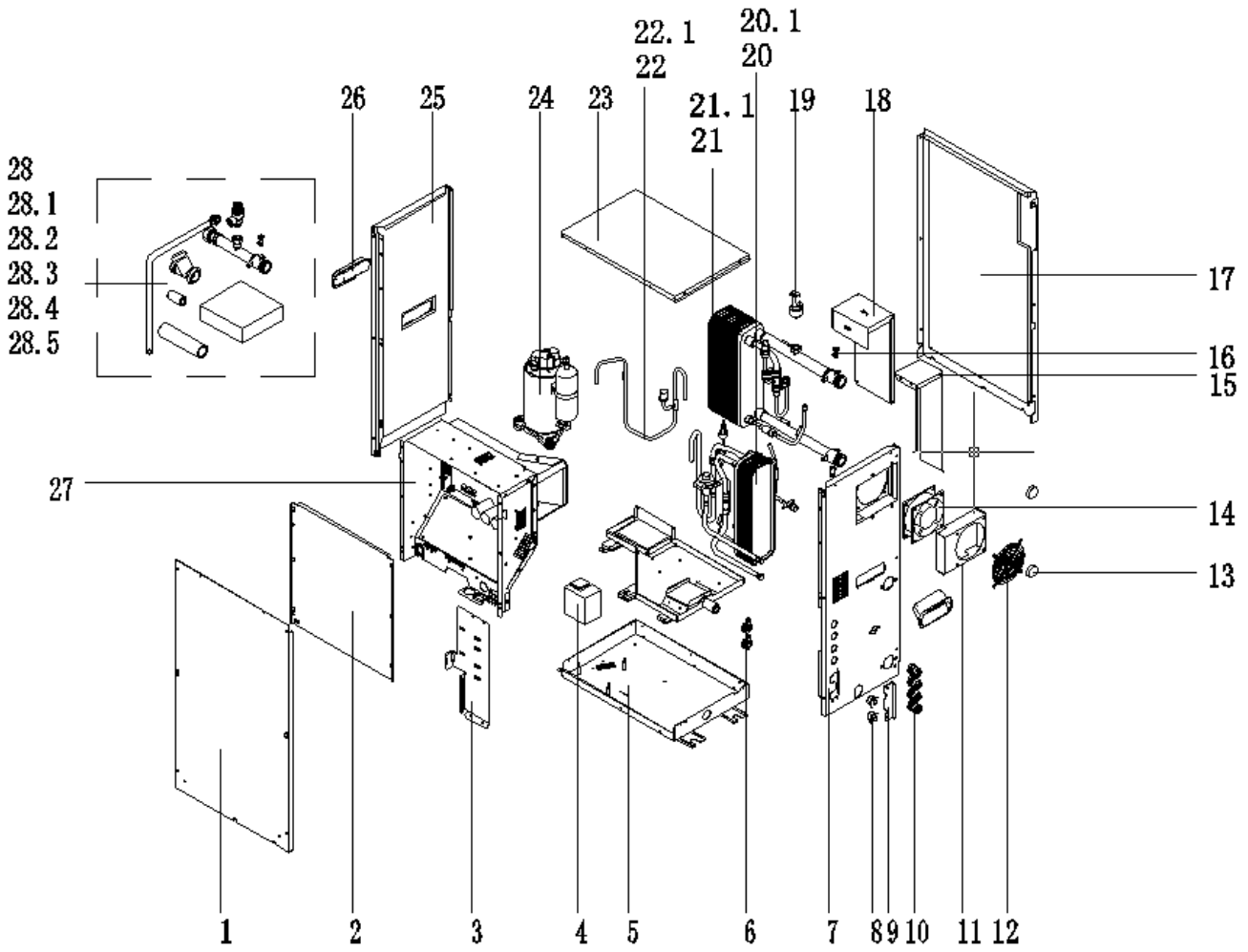

Engineering Data

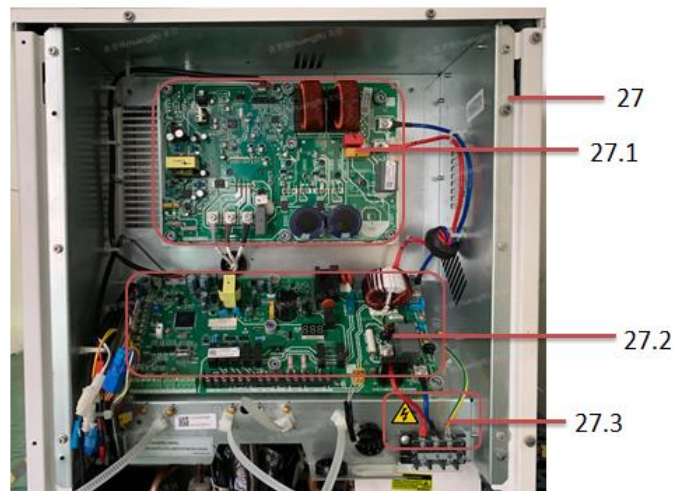

1	Front panel assembly
2	Electric control box cover assembly
3	Connecting plate
4	Pearl cotton
5	Chassis assembly
6	Pressure pipe clamp
7	Right panel assembly
8	Rubber washer
9	Connecting plate
10	Cable gland
11	Connecting plate
12	Grill
13	Dust plug
14	AC fan
15	Connecting plate
16	Drainage pipe adapter
17	Rear panel assembly
18	Connecting plate assembly
19	Flow Switch (RoHS)
20	Plate heat exchanger assembly
20.1	Plate heat exchanger assembly
21	Plate heat exchanger assembly
21.1	Plate heat exchanger assembly
22	Air discharge pipe assembly
22.1	Pressure switch
23	Top cover assembly
24	DC Inverter rotary compressor
25	Left panel assembly
26	Handle
27	E-part box assembly
27.1	Power drive mounting plate assembly
27.2	Hydro module, Main control board assembly
27.3	Wire joint
28	Accessory package
28.1	Connecting pipe assembly
28.2	Y shape filter
28.3	Accessory- Drainage hose
28.4	Wired controller
28.5	Magnetic ring
29	Water temperature sensor
30	Water temperature sensor
31	Pipe Temperature Sensor
32	Pipe Temperature Sensor
33	Pipe Temperature Sensor

6 Dimensions

6.1 Structural Dimensions

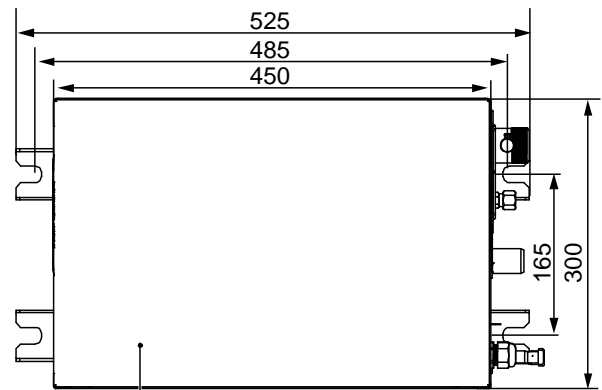
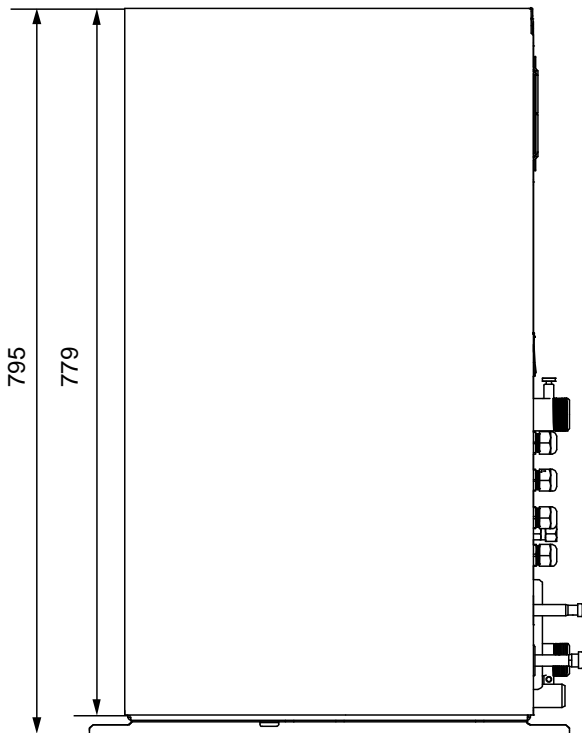

Hydro module unit (top view)

High Temperature Hydro Module



6.2 Center of gravity

Midea V6R High Temperature Hydro Module

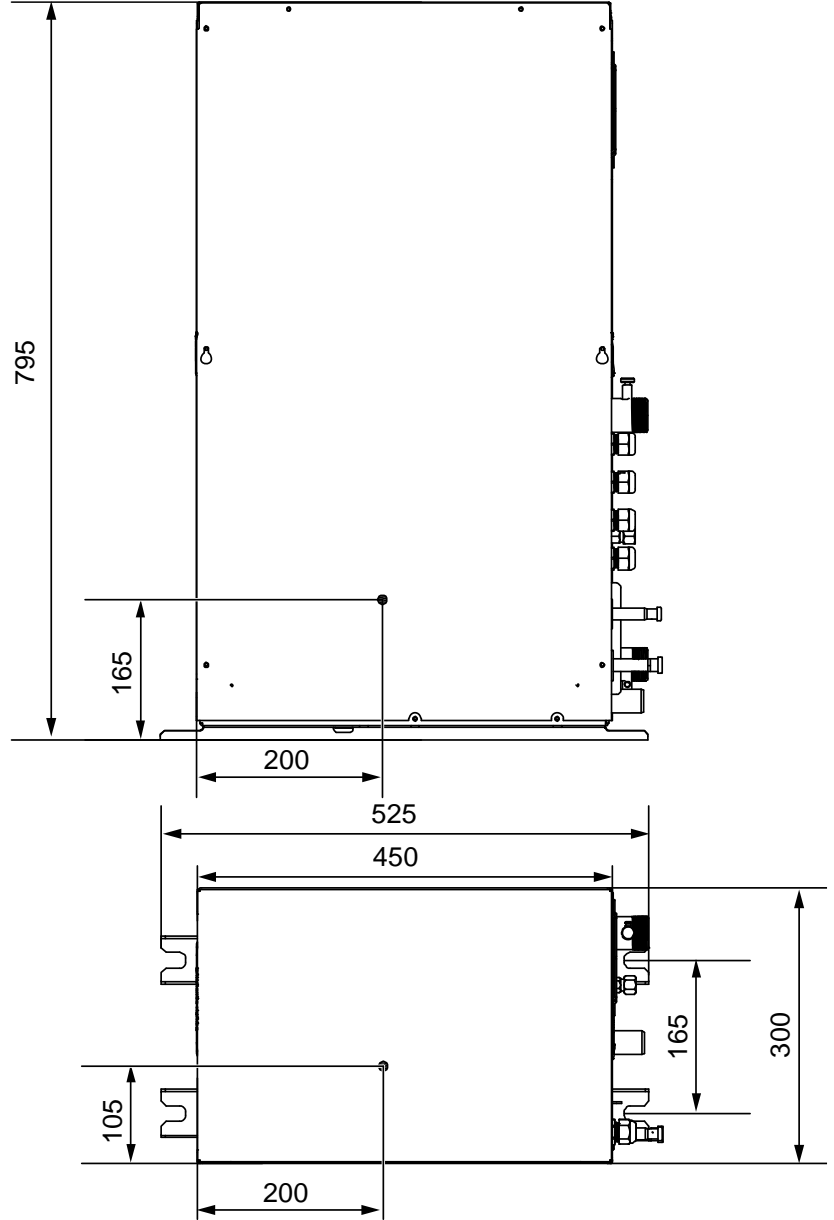
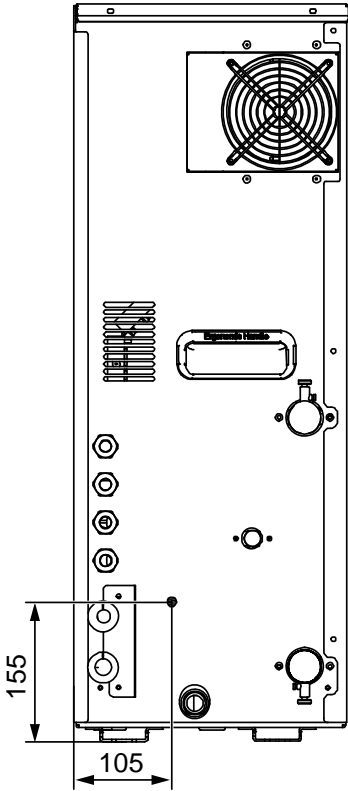

6.3 Installation Space

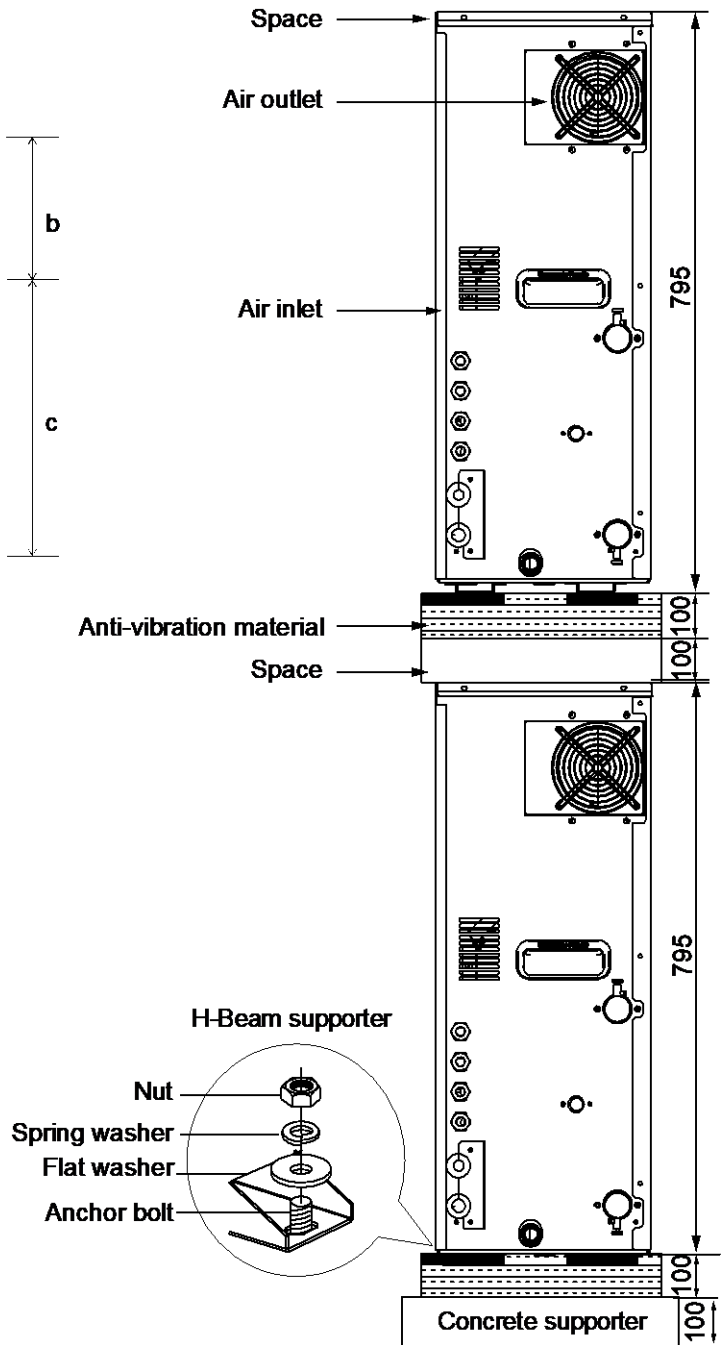
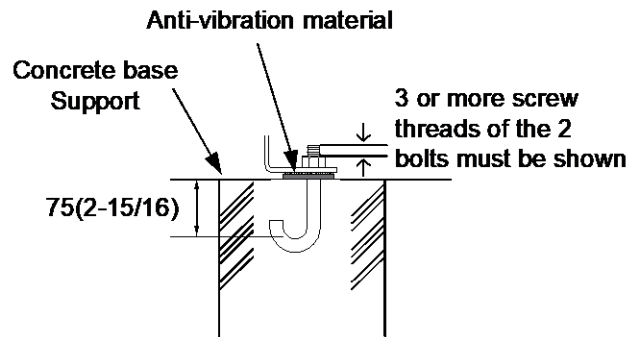
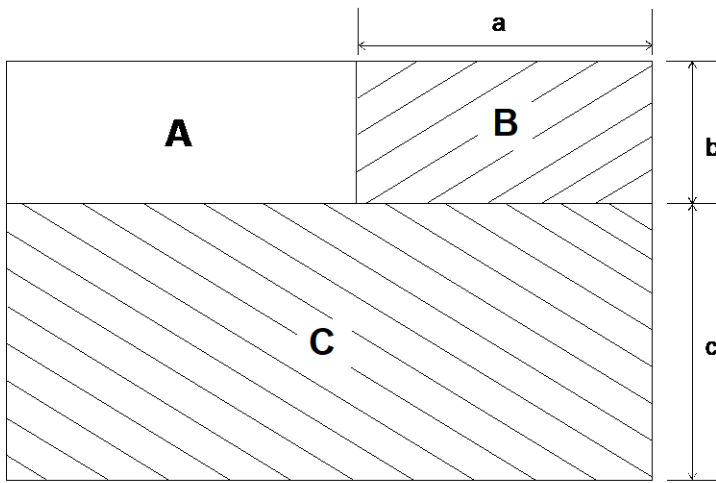

A	High Temperature Hydro module
B	Space for installing piping (on the right side)
C	Space for installation and maintenance (in the front)

6.4 General Precautions about Installation Site

Select an installation site that meets the following conditions:

- The floor that supports unit weight should be hard enough. The floor should be level to avoid vibration and noise.
- The space around the unit should be wide enough for maintenance and repair. The space dimensions are as follows: $a \geq 400$ mm; $b \geq 300$ mm; $c \geq 600$ mm. If double-layer installation is required, the upper and lower space between units should be not less than 150 mm.
- There should be enough space around the unit for ventilation.
- If flammable gas leaks, ensure that there are no hazards that could lead to fire.
- This unit is not designed to operate in an environment where explosions could occur.
- Select the installation site according to the corresponding legal provisions. The noise should not affect any person. Carefully select an installation site. Do not install the unit in an environment that is sensitive to sound, such as living rooms and bedrooms.
- If water leaks, the leakage should not cause damage to the installation site or the surroundings.
- Take enough measures according to the corresponding legal provisions to deal with refrigerant leakage.
- When the unit is installed in a small room, take measures to ensure that concentration of the leaking refrigerant cannot exceed the allowed limit.
- Do not climb, sit on, or stand on the unit.
- Do not place any article or equipment on the top of the unit (top panel of the unit).
- Do not install the unit in a workshop, for example, a construction site, because at construction sites, the equipment will be covered in dust.
- Do not install the unit in a highly damp site, such as a restroom. (The maximum relative humidity is 85%.)
- When installing the unit, reserve enough space for the air inlet and air outlet. Do not obstruct them.

Notes for installers and service engineers

Caution

In an airtight space, excessively high concentration of the refrigerant may lead to insufficient oxygen.

6.5 General precautions about the Water System

Check the following items before continuing installation:

- Max. hydro pressure: 10 bar
- Max. water temperature: 80 °C
- Install enough safety devices in the water loops to ensure that the hydro pressure does not exceed the maximum operating pressure (10 bar).
- Provide a drainage hole at all the low points of the system so that the water is completely drained from the water system when you repair or maintain the unit. A drain valve has been installed at the water inlet to facilitate water discharge from the unit's water system.
- Ensure that you have provided a suitable water discharge pipe to the safety valve to prevent water from coming into contact with any electrical part. A water discharge pipe has been provided with the unit.
- You must deploy air outlets at all the high points of the system. The air outlets should be deployed at the places where they can be easily maintained. A drain valve has been installed at the water outlet to facilitate air discharge from the unit's water system.
- Ensure that all the components installed on pipes on site can bear water pressure and water temperature.
- You should use materials that are compatible with water and equipment in the system.
- Anti-freezing protection of the water system:
- Freezing may cause damage to the system. The ODU may be exposed to temperatures below 0 C. You must prevent the system from freezing.
- All the internal water systems are insulated to prevent heat loss. On site, pipes should be fitted with insulating materials.
- The unit is designed with an anti-freezing function. The unit uses a heat pump to prevent the entire system from freezing. When the water temperature in the system decreases to a certain value, the unit will heat water. The anti-freezing function will be disabled only when the water temperature rises to a certain value.
- In the event of power failure, the anti-freezing function cannot protect the unit from freezing.
- Using anti-freezing liquid in the water system is recommended, because power failure may happen when no one is present.
- Ensure that the water system is full of the ethylene glycol concentration provided in the following table, according to the expected lowest outdoor temperature. When ethylene glycol is added to the system, device performance will be affected. The following table lists the correction coefficients of the unit capacity, flow, and pressure drop of the system.

<i>Ethylene Glycol</i>					
Quality of Glycol %	Modification Coefficient				Freezing Point in degree C
	Cooling Capacity Modification	Power Modification	Water Resistance	Water Flow Modification	
0	1.000	1.000	1.000	1.000	0.0000
10	0.984	0.998	1.118	1.019	-4.000
20	0.973	0.995	1.268	1.051	-9.000
30	0.965	0.992	1.482	1.092	-16.000
40	0.960	0.989	1.791	1.145	-23.000
50	0.950	0.983	2.100	1.200	-37.000

<i>Propylene Glycol</i>					
Quality of Glycol %	Modification Coefficient				Freezing Point in degree C
	Cooling Capacity Modification	Power Modification	Water Resistance	Water Flow Modification	
0	1.000	1.000	1.000	1.000	0.0000
10	0.976	0.996	1.071	1.000	-3.000
20	0.961	0.992	1.189	1.016	-7.000
30	0.948	0.988	1.380	1.034	-13.000
40	0.938	0.984	1.728	1.078	-22.000
50	0.925	0.975	2.150	1.125	-35.000

- If ethylene glycol is not added, water must be discharged when power is cut off

6.6 Checking, Handling and Unpacking the Unit

- When the unit is delivered, you must check the equipment and immediately report damage (if any) to the claims agent of the carrier.
- Put the packaged unit as close as possible to its final installation site to prevent damage during the handling process.
- Check all the accessories of the IDU. (For details, see “1. Accessories” on page 1.)

Notes for installers and service engineers

Caution

- Remove the plastic packaging bag so that children cannot play with it. Children may face the danger of death by suffocation if playing with the plastic packaging bag.
- Both ethylene glycol and propylene glycol are toxic substances. The concentration mentioned in the preceding table cannot prevent freezing, but can prevent breaking caused by liquid pressure.

6.7 Installation Diagram

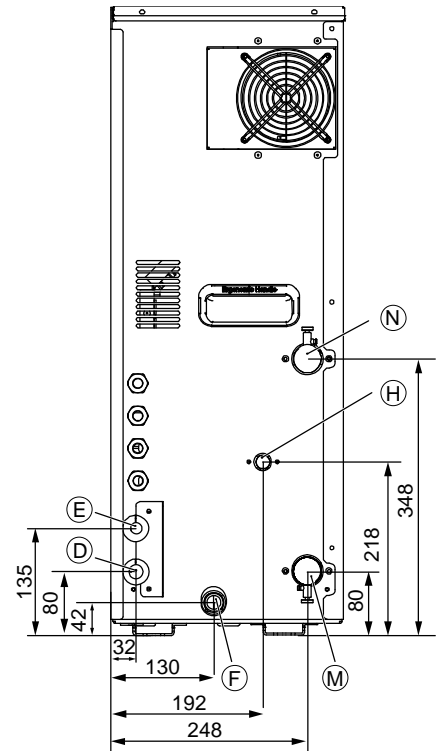
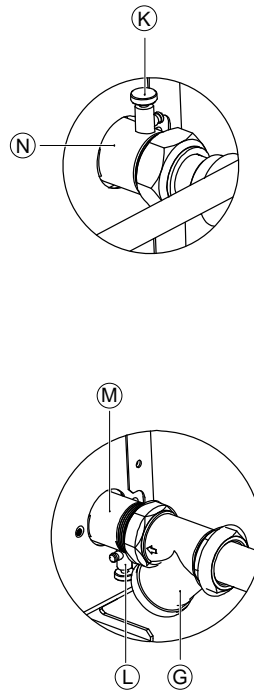
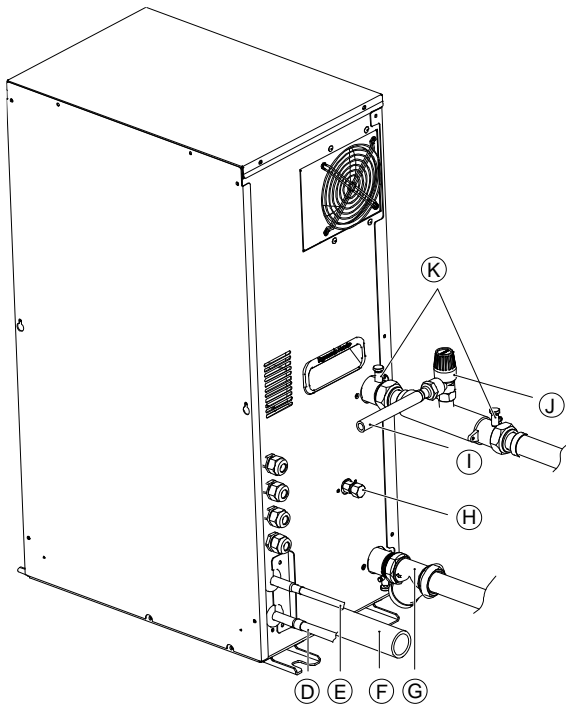

- Ⓓ Liquid pipe (connected to the ODU)
- Ⓔ Gas pipe (connected to the ODU)
- Ⓕ Water discharge pipe (drainage pan)
- Ⓖ Y-shaped filter
- Ⓗ Access hole (for charging/discharging refrigerant)
- Ⓘ Water discharge pipe (safety valve)
- Ⓣ Safety valve
- Ⓚ Discharge valve
- Ⓛ Drain valve
- Ⓜ Water inlet
- Ⓝ Water outlet

7 Capacity Tables

Variable Inlet Temperature influence on Capacity and Power

Water flow	EW																	
	30		40		50		55		60		65		70		75		80	
m3/h	HC	PI	HC	PI	HC	PI	HC	PI	HC	PI	HC	PI	HC	PI	HC	PI	HC	PI
2.4	14	1035	14	1594	14	2117	14	2379	14	2641	14	2903	12.1	2984	9.2	2984	7.1	2984

HC: Heating Capacity(kW)

PI: Power Input (W)

EW: Inlet Water Temperature (°C)

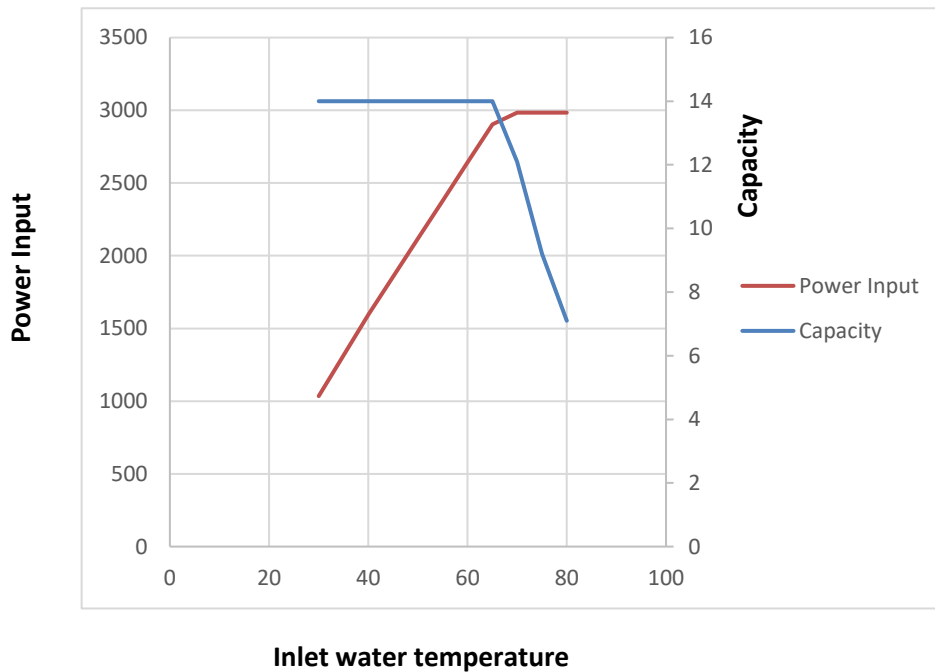

Variable Water Flow Influence on Capacity and Power

Water flow(m3/h)											
1.2		1.5		1.8		2.1		2.4		2.9	
HC	PI	HC	PI	HC	PI	HC	PI	HC	PI	HC	PI
100%	114%	100%	108%	100%	104%	100%	102%	100%	100%	100%	98%

HC: Heating Capacity(kW)

PI: Power Input (W)

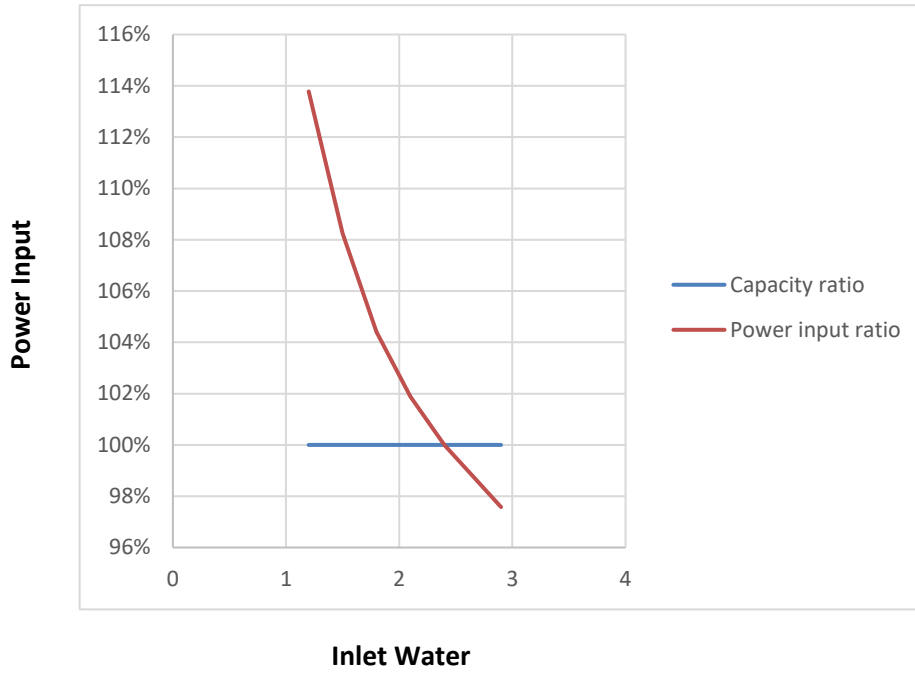

8 Unit Installation

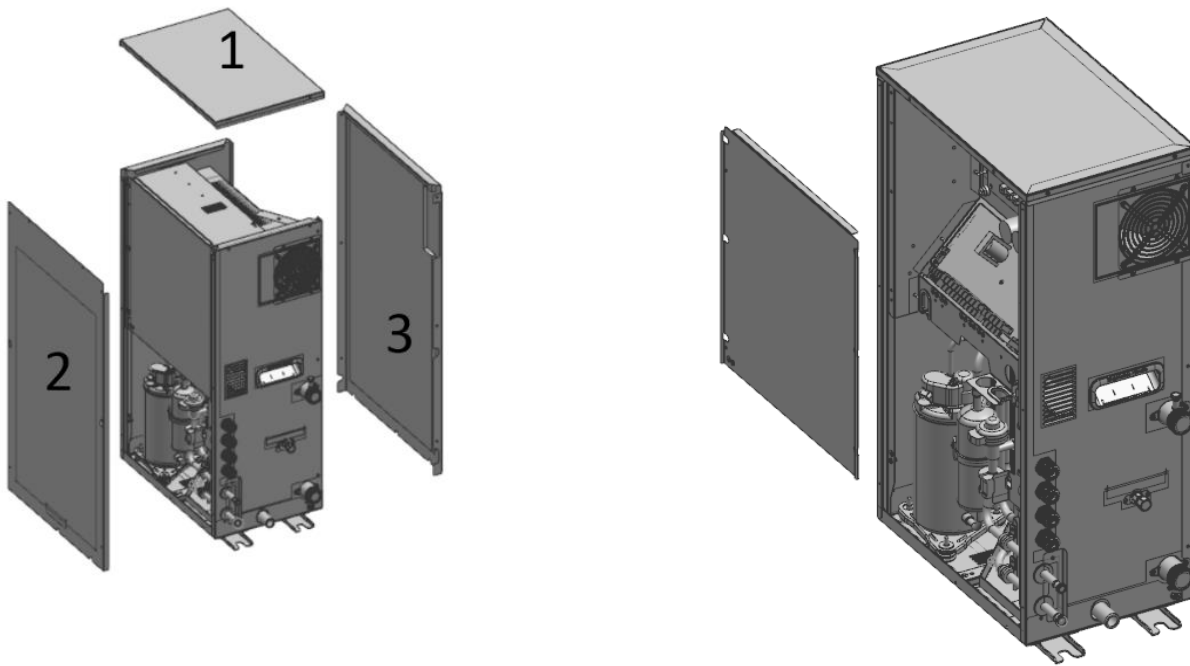

Midea V6R High Temperature Hydro Module

Notes for installers and service engineers

Caution

The unit should be installed by professional installation operators. Material selection and installation must confirm with the local legal provisions.

- To check the interior of the unit, open the top panel, front panel, and rear panel first. After you open these three panels, you can see the main parts of the unit. If you just install or maintain the internal parts of the electric control box, you need to open the front panel without needing to open the top or rear panel.

- 1 Top panel
- 2 Front panel
- 3 Rear panel

To open the electric control box and operate the interior of the electric control box, open the electric control box cover plate.
To open the electric control box, you can open the front panel without needing to open the top or rear panel.

Main parts of the unit

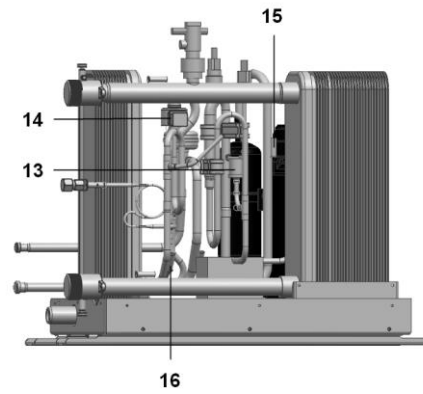
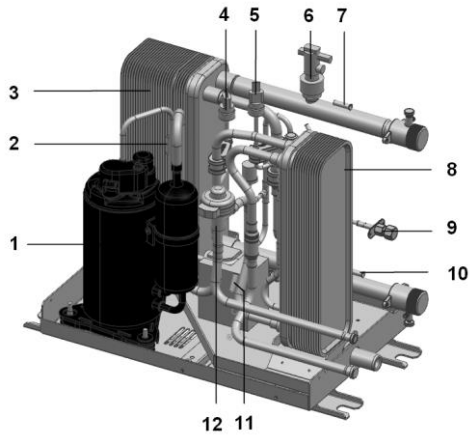

1	Compressor	9	Access hole
2	Discharge temperature sensor	10	Water inlet temperature sensor
3	Plate heat exchanger used by the condenser	11	Liquid pipe temperature sensor at the outlet on the R410A refrigerant side
4	Low pressure sensor	12	Electronic expansion valve on the R410A loop
5	High pressure sensor	13	High pressure switch
6	Water flow switch	14	Electronic expansion valve on the R134a loop
7	Water outlet temperature sensor	15	Suction temperature sensor
8	Plate heat exchanger used by the evaporator	16	Cold outlet temperature sensor on the R134a refrigerant side

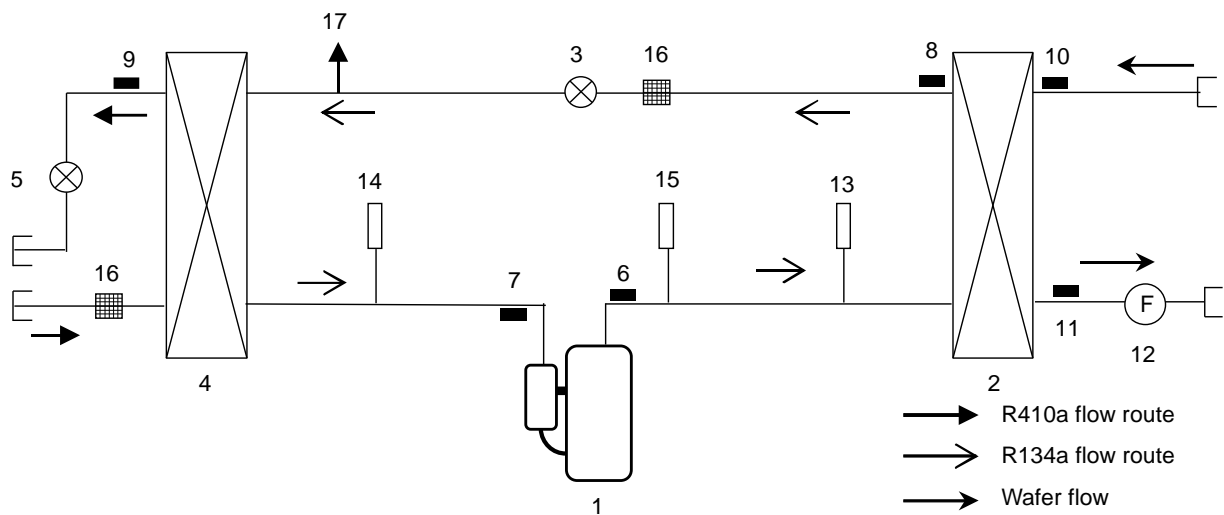

1	Compressor	10	Water inlet temperature sensor
2	Plate heat exchanger used by the condenser	11	Water outlet temperature sensor
3	Electronic expansion valve on the R134a loop	12	Water flow switch
4	Plate heat exchanger used by the evaporator	13	High pressure sensor
5	Electronic expansion valve on the R410A loop	14	Low pressure sensor
6	Discharge temperature sensor	15	High pressure switch
7	Suction temperature sensor	16	Filter
8	Cold outlet temperature sensor on the R134a refrigerant side	17	Access hole
9	Liquid pipe temperature sensor at the outlet on the R410A refrigerant side		

- Connecting pipes on the refrigerant side and water system side
- Use screw thread to connect the pipe on the water system side. Tighten the pipe to avoid water leakage.
- Brazing is required on the refrigerant side.

Notes for installers and service engineers

Brazing Precautions

- In the event of brazing, please use nitrogen for sweeping. This can prevent the occurrence of oxidation inside pipes. Oxidation will have adverse effects on the valves and compressors in the cooling system, and may hamper normal operations.
- Use the pressure relief valve to set the nitrogen pressure to 0.02 MPa (a pressure that can just be felt by the skin).
- Do not use antioxidants when brazing pipe connectors. Residues will block pipes and damage equipment.
- Do not use a flux when brazing copper refrigerant pipes. Use copper-phosphorus alloys (BCuP) where no flux is required.
- Flux is harmful to the cooling pipe system. For example, if a chlorine-based flux is used, pipes will be corroded. Especially when the flux contains fluorine, the flux will degrade the frozen oil.

Connecting wires

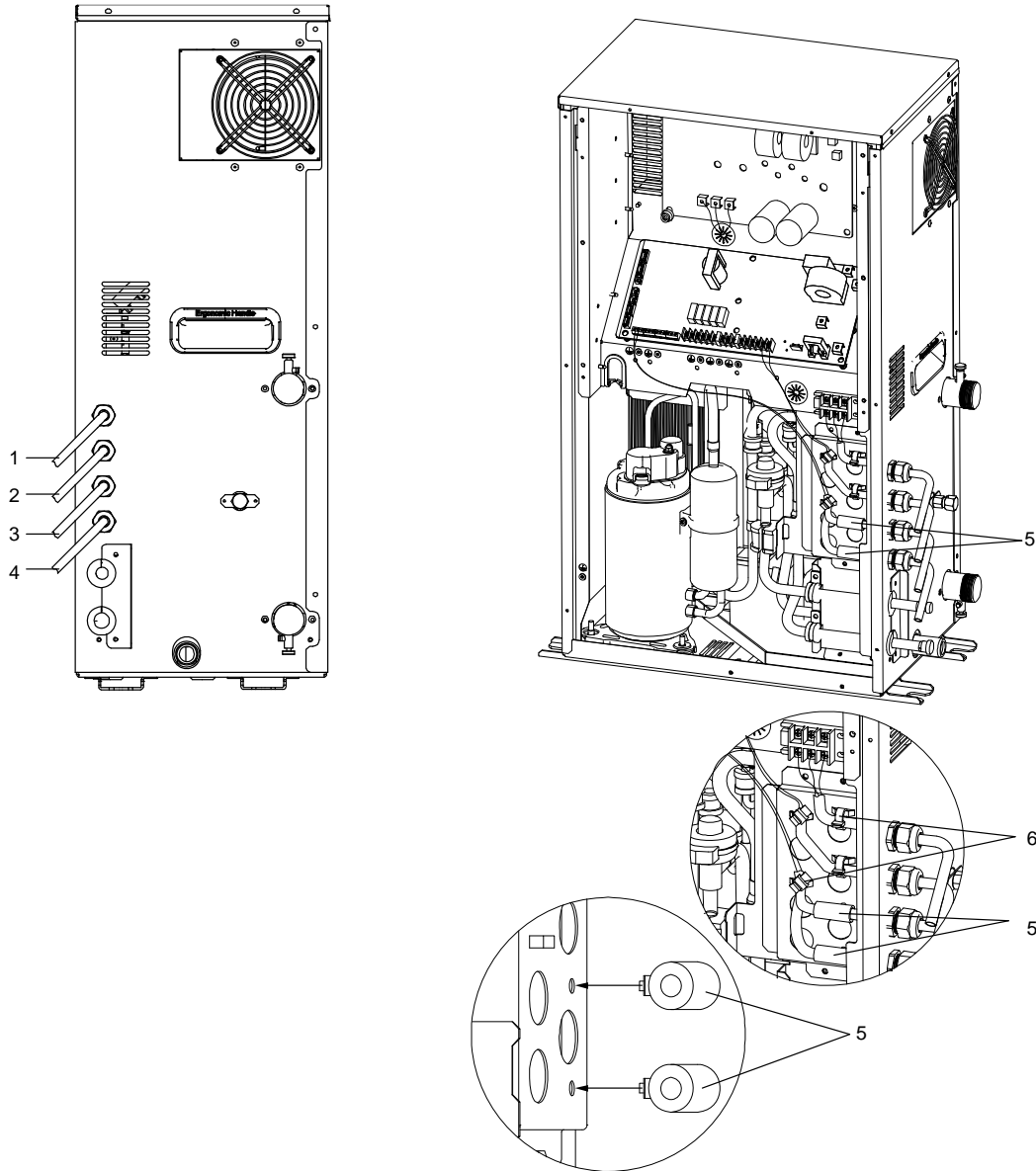

1	Power input
2	High Voltage Signal
3	Low Voltage Signal
4	Communication Cables
5	Magnetic Ring
6	Cable Tie

- When the external wire enters the interior of the unit through a waterproof cable connector, you need to separate the strong-current cable from the weak-current cable for cabling. For details, see the diagram.
- Inside the unit, wires should be fixed by using a cable tie through the overpass-shape component.
- Both the signal cable and output cable must be fitted with a magnetic ring, and then fixed on the overpass-shaped component by using a cable tie.

High Temperature Hydro Module

- Connection for other components

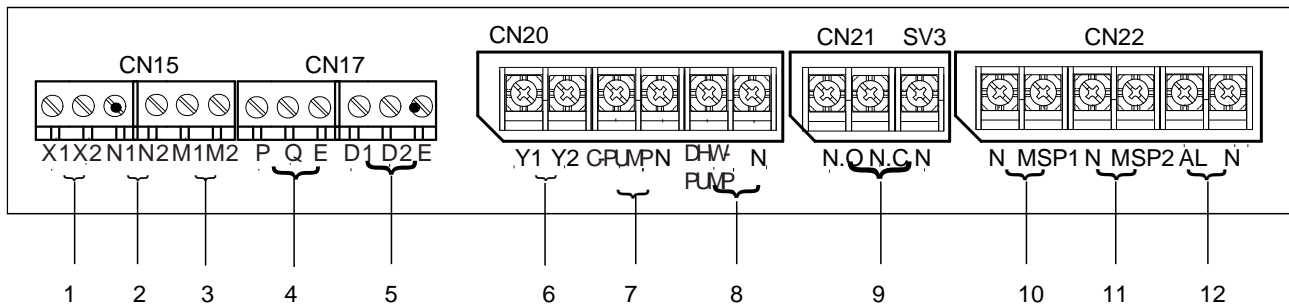

Coding	Assembly unit	Coding	Assembly unit
1	Connecting the wired controller	7	Connecting the circulating water pump AC contactor
2	Free electrical signal	8	Connecting the AC contactor for controlling water tanks and water pumps
3	Cheap electrical signal	9	Connecting the three-way valve
4	Outdoor/MS units communication .bus	10	Energy demand adjustment 1 input
5	Hydro module group control interface/connecting to the KNX gateway	11	Energy demand adjustment 2 input
6	Reserved	12	Alarm output -230 V~

- Wired controller wiring

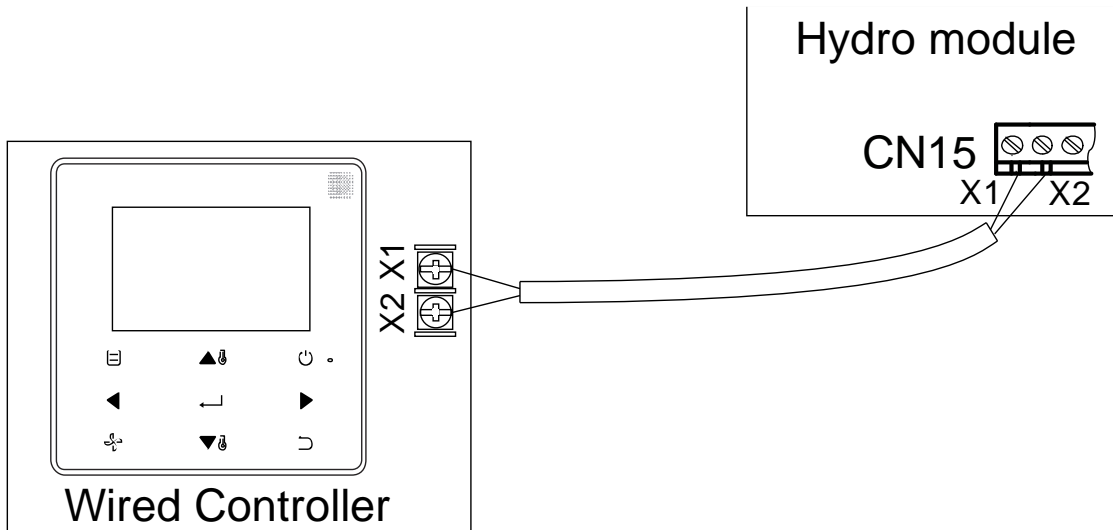

- Wires X1 and X2 do not have polarity requirements.

Voltage	18 V DC
Maximum running current (A)	0.1
Wiring size (mm ²)	2x0.5

- Free electrical signal port N1/N2
- Cheap electrical signal port M1/M2

Used for energy management and to identify cheap or free electricity. When N1 is connected to N2, the electricity is determined to be free electricity. When M1 is connected to M2, the electricity is determined to be cheap electricity. When receiving cheap or free electrical signal, the hydro module will automatically start. (For detailed settings, refer to the Service Manual)

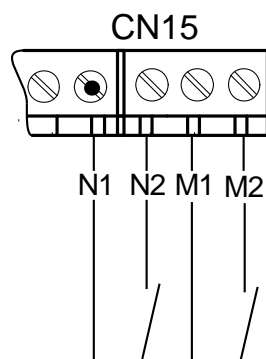

Voltage	12 V DC
Maximum running current (A)	< 0.1
Wiring size (mm ²)	2x0.5

- Connection line group for IDU and ODU / MS communication

Used to connect IDU and ODU communication and transfer the control signals of the IDU and ODU. Please use the wire with a shield layer and ensure that the shield layer is grounded. For instructions on how to connect the ODU or MS, please see the corresponding manual.

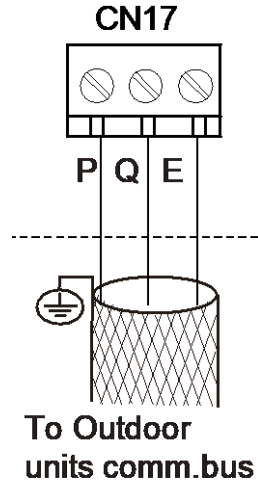

Voltage	2.5~2.7 V DC
Maximum running current (A)	< 0.1
Wiring size (mm ²)	2x0.75 shielded cable

- Group control connection method/KNX gateway connection method
- The hydro module can provide the function of group control so that one module can control multiple units. In the entire system, only one master wired controller can be deployed to control units. Each unit can connect one slave wired controller for data query.
- Up to 10 units can be controlled.

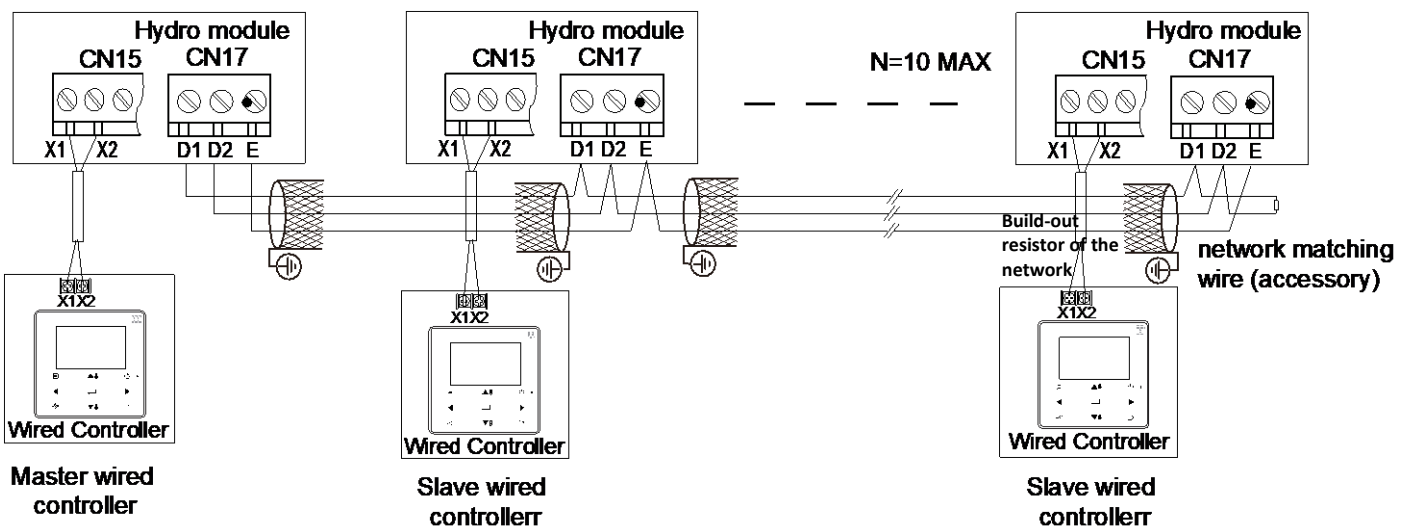

- The hydro module can connect the KNX gateway via D1\D2\E so that the third-party wired controller can control the hydro module. In this case, X1 and X2 can be used for check query by connecting or without connecting the wired controller, but cannot be used for control.

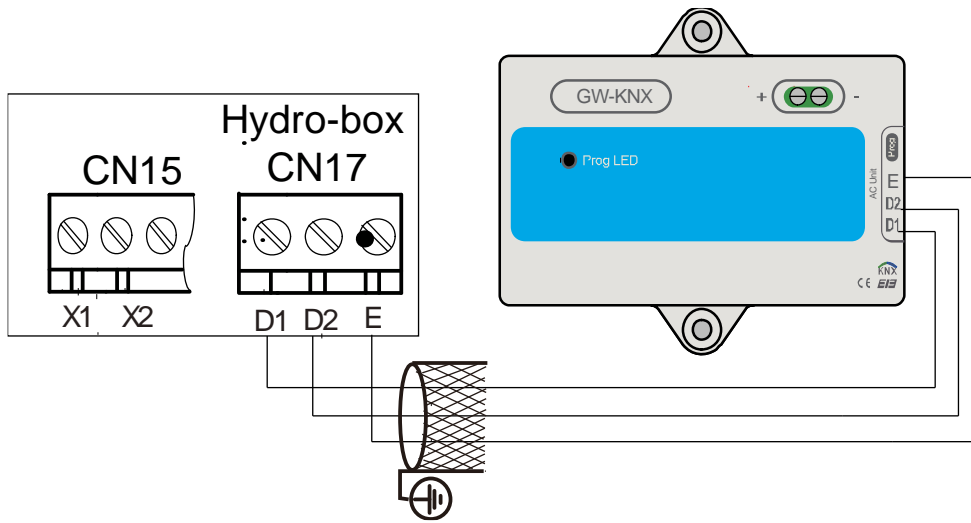

Voltage	2.5~2.7 V DC
Maximum running current (A)	< 0.1
Wiring size (mm ²)	3x0.75 shielded cable

High Temperature Hydro Module

- Reserving Y1/Y2 at port
- Output control interface of the circulating water pump
- Output control interface of the water tank and water pump

Note: The circulating water pump, water tank and water pump are connected to an external contactor for control. Do not directly connect the water pump.

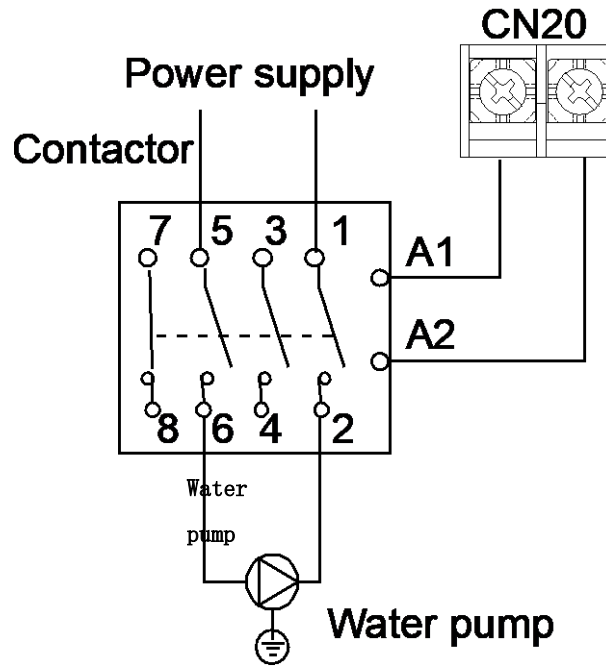

Voltage	220-240V
Maximum running current (A)	2
Wiring size (mm ²)	2x0.75

- Controlling ports via a three-way valve

The three-way valve offers the following two methods, subject to the models sold in the market. For details, see the three-way valve manual. N.O indicates normally open output, while N.C indicates normally closed output.

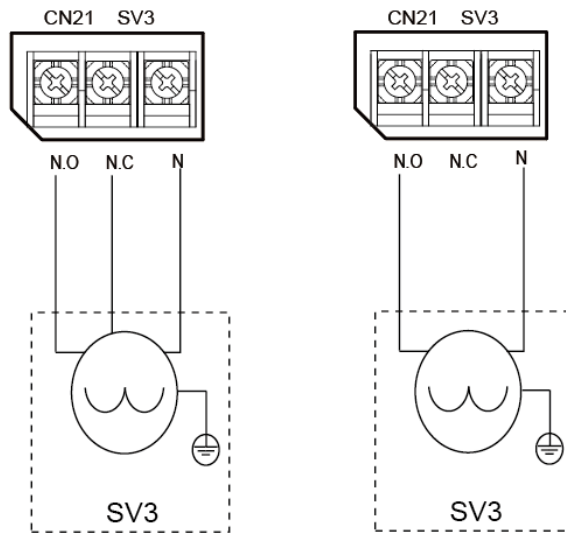

Voltage	220-240V~
Maximum running current (A)	1
Wiring size (mm ²)	3x0.75

- Three-way valve installation**

Check the three-way valve type. Connect it to the electric control board. For instructions on how to connect ports and wires.

Note: Before installing the three-way valve, check the port opening direction.

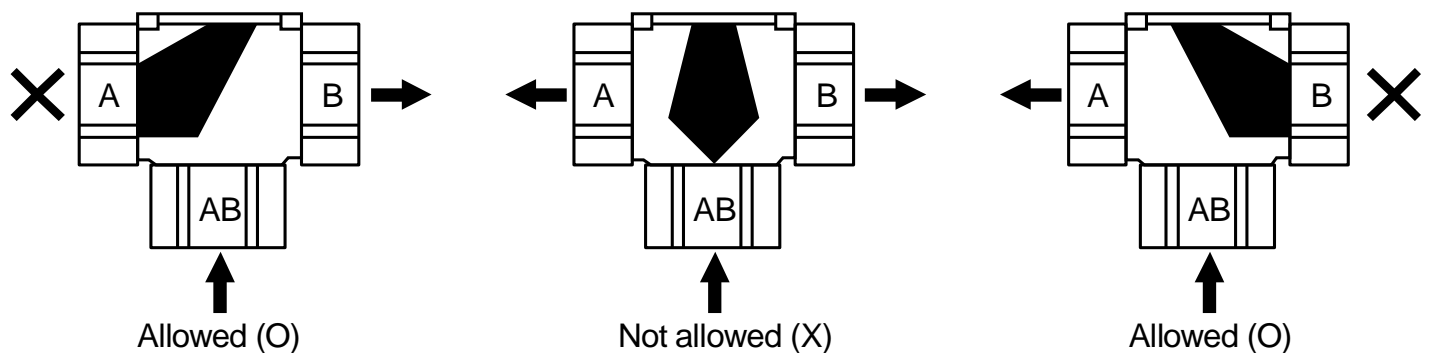

- Input port 1 of temperature multiple set point
- Input port 1 of temperature multiple set point

High Temperature Hydro Module

To set the temperature at multiple points, connect a third-party thermostat to set different temperature set points.

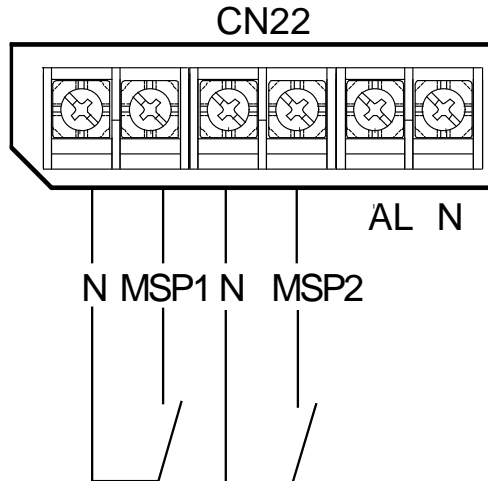

Voltage	220-240V~
Maximum running current (A)	< 0.1
Wiring size (mm ²)	2x0.75

- **Alarm output signal**

When the unit fails, a signal can be output to indicate the unit status.

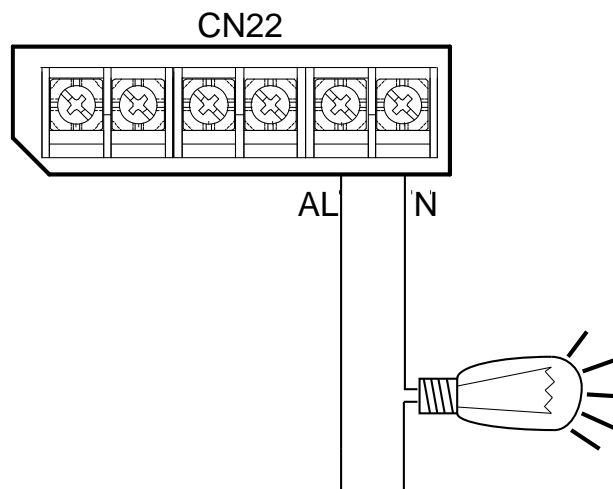

Voltage	220-240V~
Maximum running current (A)	2
Wiring size (mm ²)	2x0.75

Note: After wires are connected, do not place the redundant wires into the unit.

- **Installing the wired controller**

This unit is equipped with a wired controller, which is used to set, operate, and maintain this unit. Before operating the wired controller, please follow the installation procedures.

Notes for installers and service engineers

Caution

- The connecting wire is excluded tank temperature. The hydro module controls the three-way valve to switch to heating or DHW modes.
- The wired controller is delivered as a kit and must be installed indoors.
- When the temperature control function of the wired controller is used, please select an installation site that satisfies the following conditions:
 - The average temperature of the room can be detected.
 - The installation site is free from direct sunshine.
 - The installation site is not near the heat source and the temperature is between 0 °C and 50 °C.
 - The installation site is not affected by outdoor air or air pressure, for example, opening/closing of the door.
 - The display can be kept clean.

- **Wired controller dimensions**

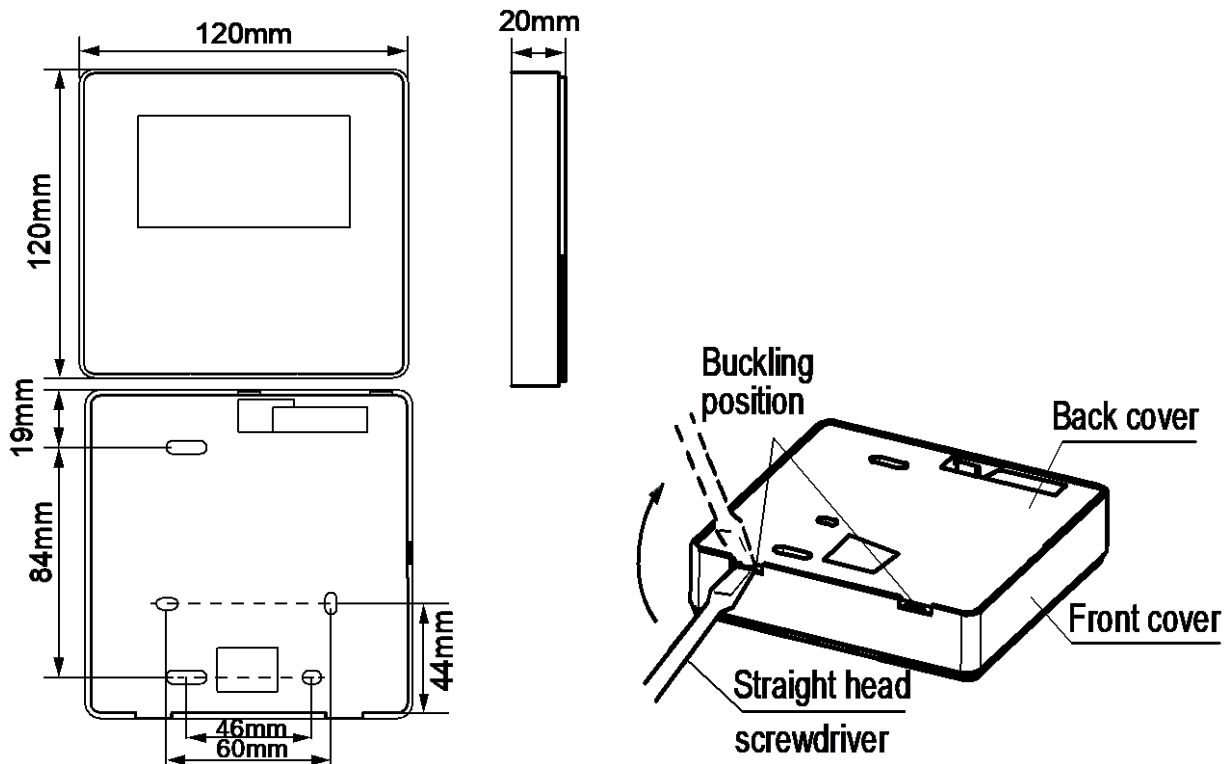

- ① Insert the tip of a straight head screwdriver into the bending location at the bottom of the wired controller. Raise the screwdriver to pry open the rear cover. Pay attention to the direction when prying open the rear cover. Prying in an incorrect direction will damage the rear cover.

- ② Fix the rear cover on the wall.

Note: Do not excessively tighten the installation screws to prevent rear cover deformation of the wired controller.

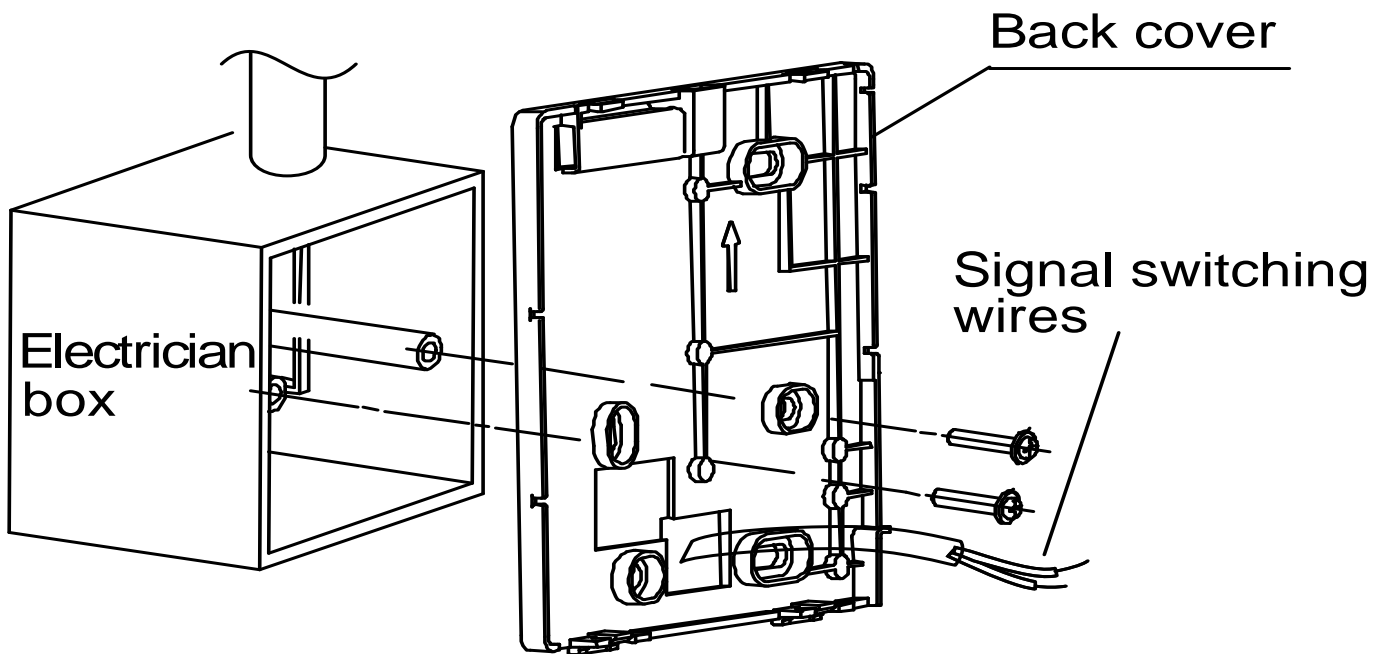
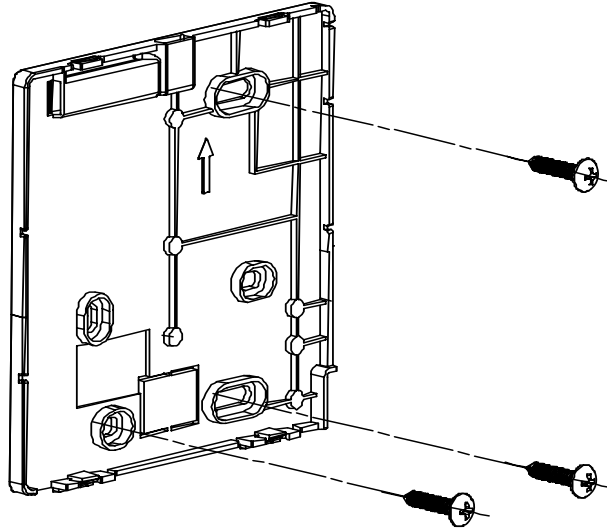

③ Wire the wired controller.

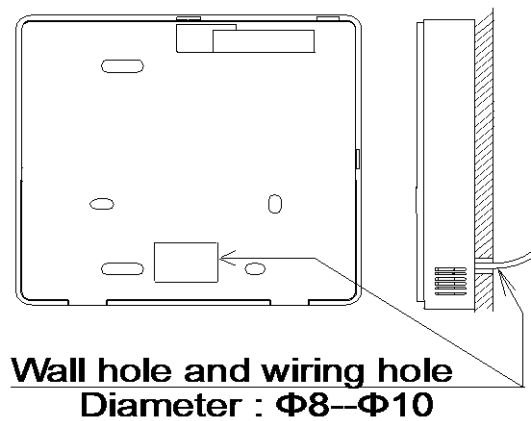
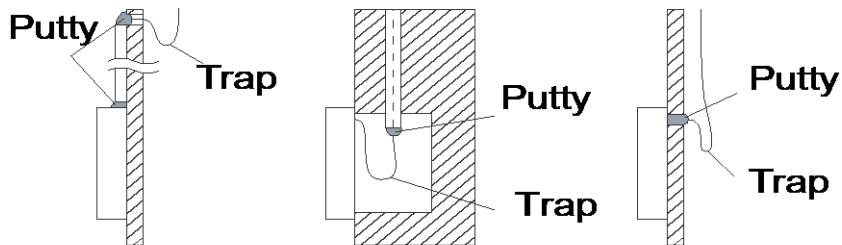
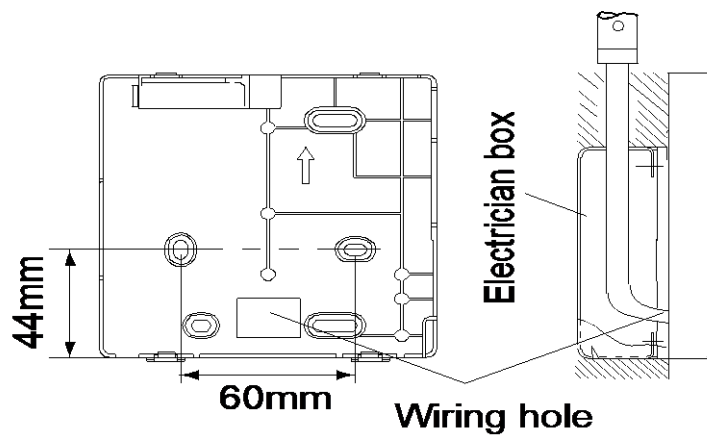
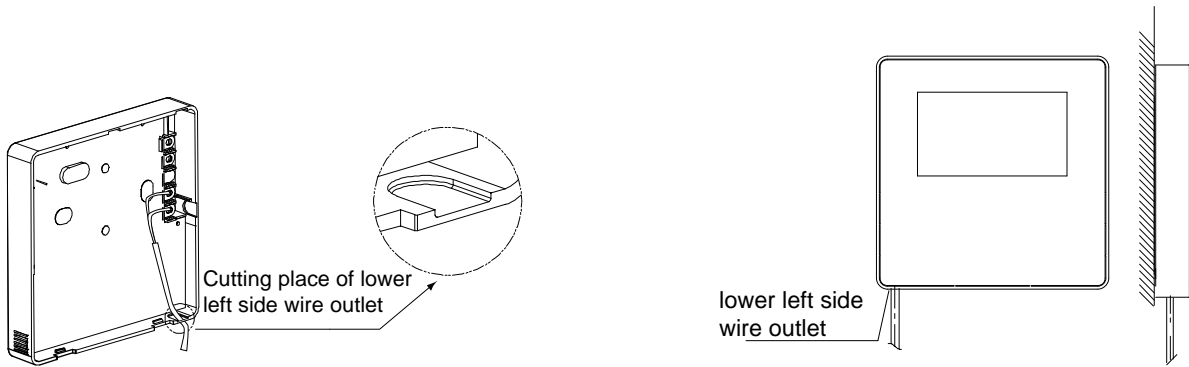

④ Connect the wired controller to the unit.

Note: * Do not jam wires during installation.

9 Application Examples

Only heating mode is available and the heating mode operates in water outlet temperature control mode.

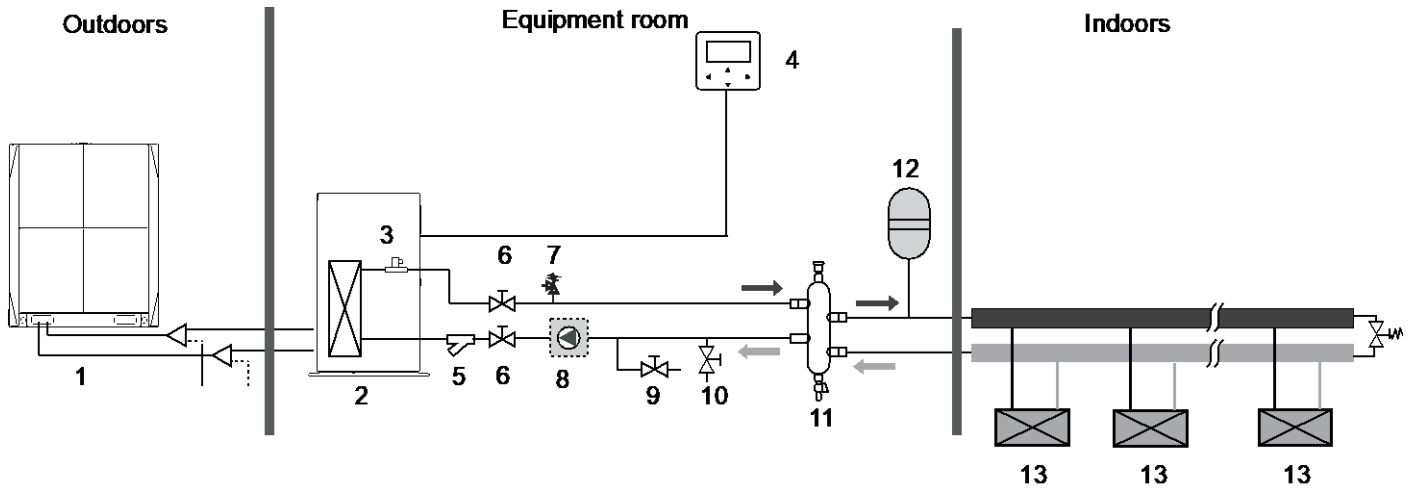

1	ODU
2	Hydro module
3	Water flow switch
4	Wired controller (Accessory)
5	Y-shaped filter (Accessory)
6	Check valve (Provided on site)
7	Safety valve (Accessory)
8	Water pump (Provided on site. For model selection, see page 32.)
9	Drain valve (Provided on site)
10	Water replenishing valve (Provided on site)
11	Water collector (Provided on site)
12	Water expansion tank (Provided on site. For model selection, see page 33.)
13	Terminals. The unit can connect to the floor heating device FHL (25 °C-45 °C), fan coil FCU (45 °C-60 °C), and radiator (60 °C-80 °C), which have different temperature requirements.

On-site settings of the wired controller:

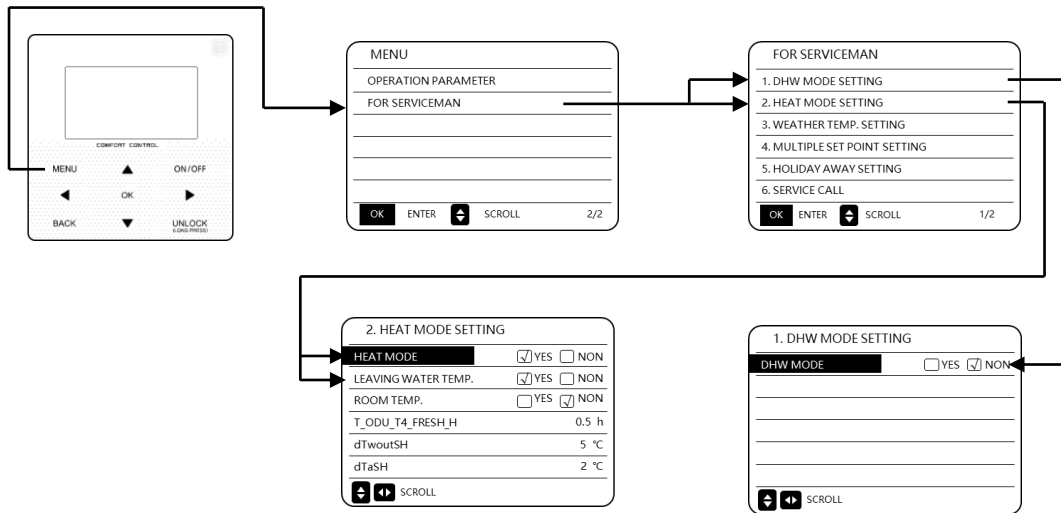

HEAT MODE=YES
Heat mode is valid.
LEAVING WATER
TEMP.=YES
Water outlet temperature
control is valid.

DHW MODE=NON
DHW mode is
invalid.

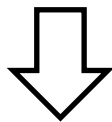

Temperature
settings

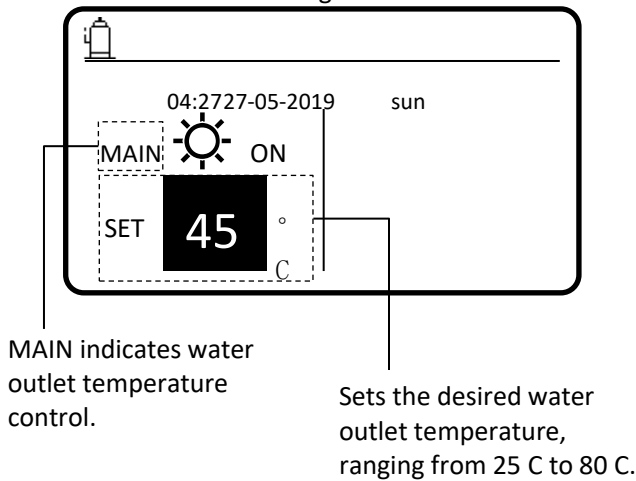

MAIN indicates water
outlet temperature
control.

Sets the desired water
outlet temperature,
ranging from 25 C to 80 C.

High Temperature Hydro Module

Only heating mode is available and the heating mode operates in room temperature control mode.

Midea V6R High Temperature Hydro Module

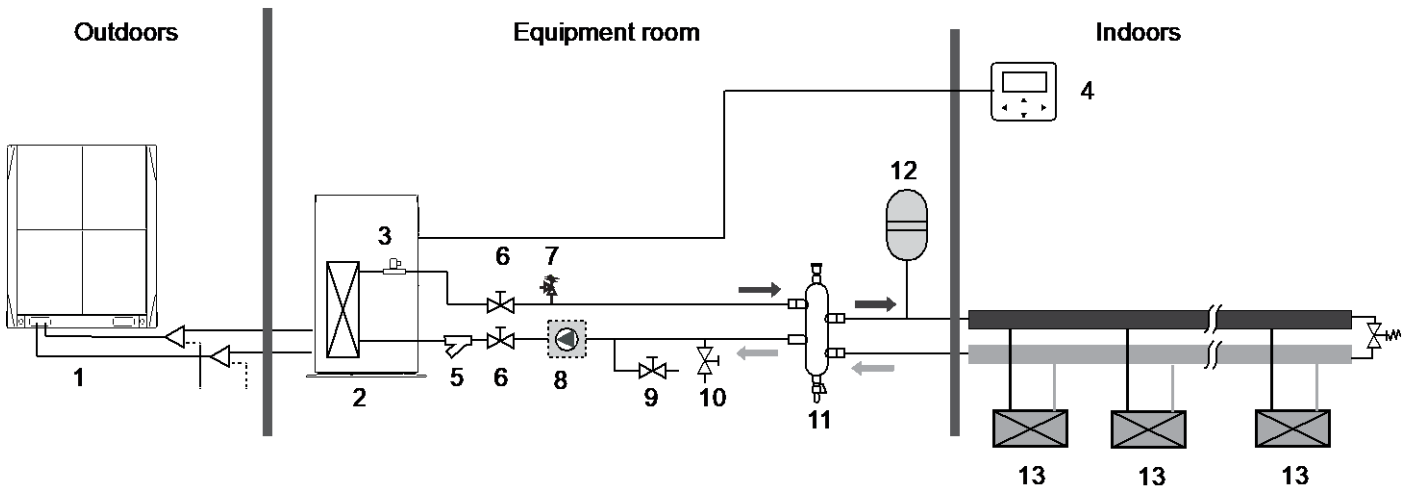

1	ODU
2	Hydro module
3	Water flow switch
4	Wired controller (Accessory)
5	Y-shaped filter (Accessory)
6	Check valve (Provided on site)
7	Safety valve (Accessory)
8	Water pump (Provided on site. For model selection, see page 32.)
9	Drain valve (Provided on site)
10	Water replenishing valve (Provided on site)
11	Water collector (Provided on site)
12	Water expansion tank (Provided on site. For model selection, see page 33.)
13	Terminals. The unit can connect to the floor heating device FHL (25 °C-45 °C), fan coil FCU (45 °C-60 °C), and radiator (60 °C-80 °C), which have different temperature requirements.

Note: *The wired controller is placed indoors. Room temperature is detected by the embedded temperature sensor.

On-site settings of the wired controller:

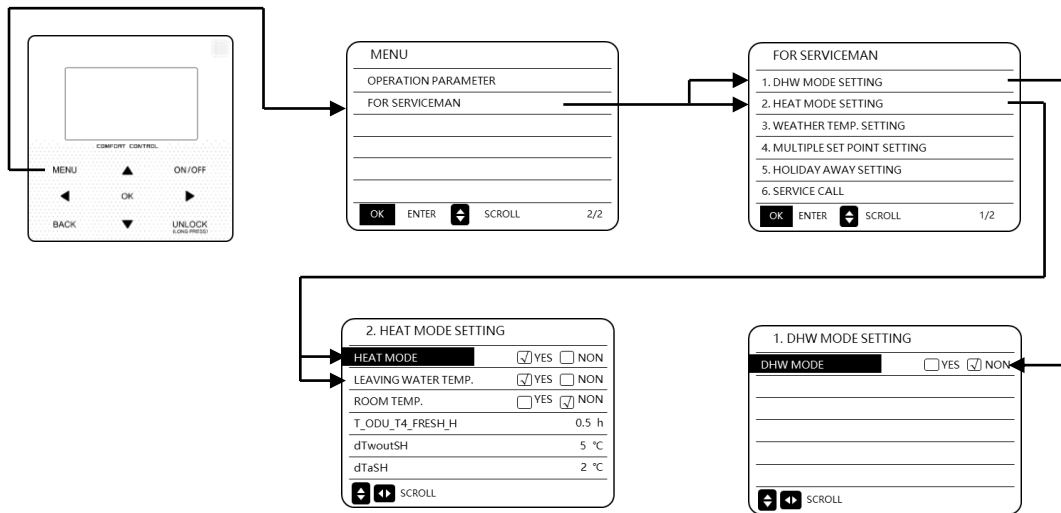

HEAT MODE=YES
Heat mode is valid.
LEAVING WATER TEMP.=YES
Water outlet temperature control is valid.

DHW MODE=NON
DHW mode is invalid.

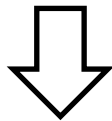

Temperature settings

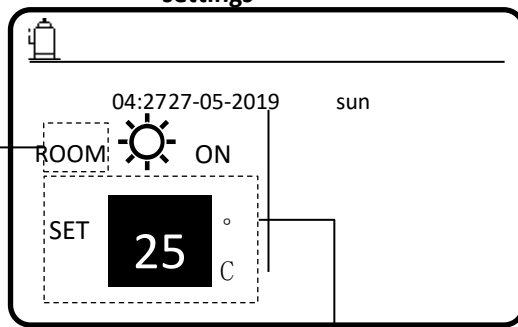

ROOM indicates room temperature control.

Sets the desired room temperature, ranging from 17 C to 30 C.

High Temperature Hydro Module



Only DHW mode is available.

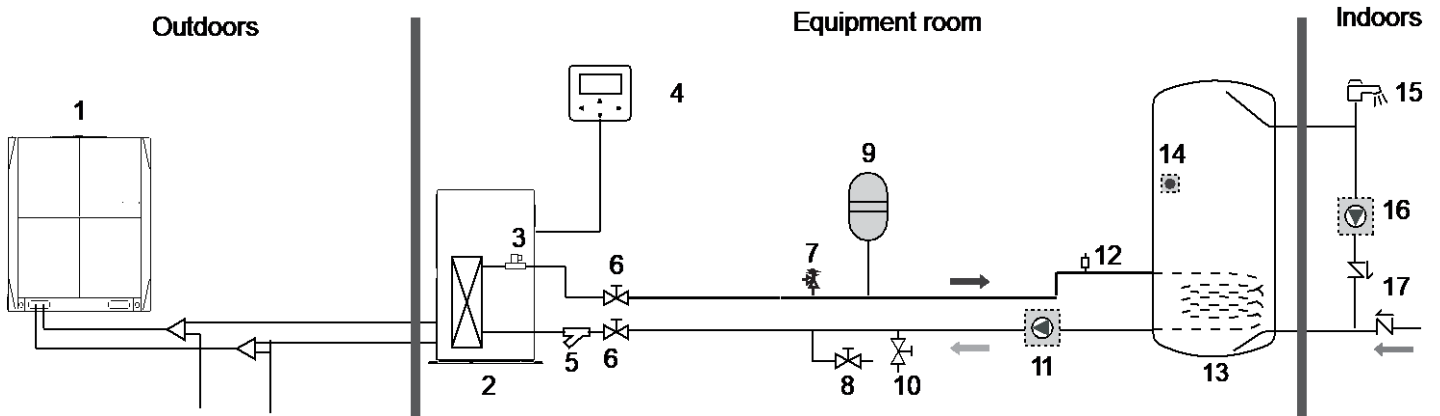

1	ODU
2	Hydro module
3	Water flow switch
4	Wired controller (Accessory)
5	Y-shaped filter (Accessory)
6	Check valve (Provided on site)
7	Safety valve (Accessory)
8	Drain valve (Provided on site)
9	Water expansion tank (Provided on site. For model selection, see page 32.)
10	Water replenishing valve (Provided on site)
11	Water pump (Provided on site. For model selection, see page 33.)
12	Discharge valve (Provided on site)
13	Water tank (Provided on site)
14	Temperature sensor of the water tank (Accessory)
15	Tap (Provided on site)
16	Water tank and water pump (Provided on site)
17	One-way valve (Provided on site)

On-site settings of the wired controller:

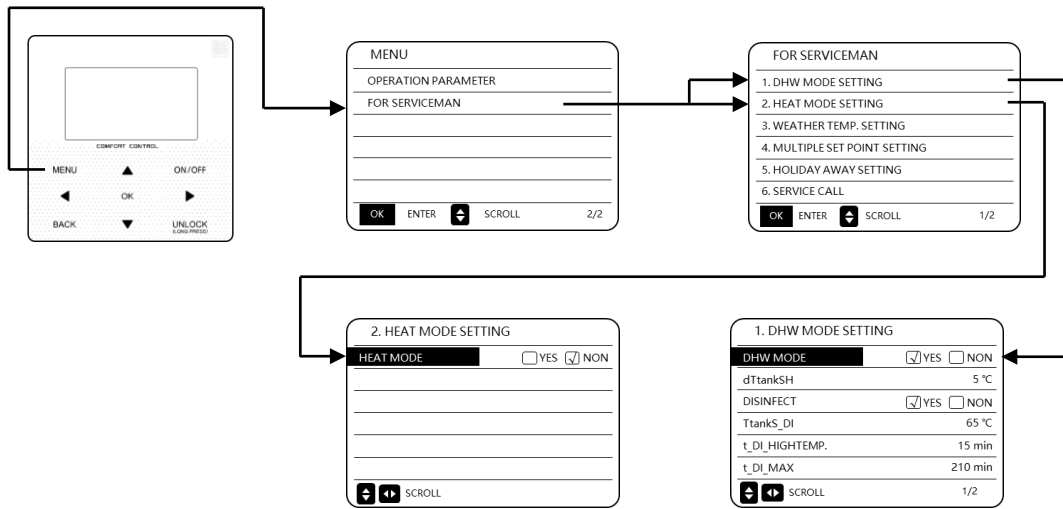

DHW MODE=NON
Heat mode is invalid.

DHW MODE=YES
DHW mode is invalid.

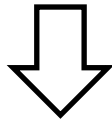

Temperature settings

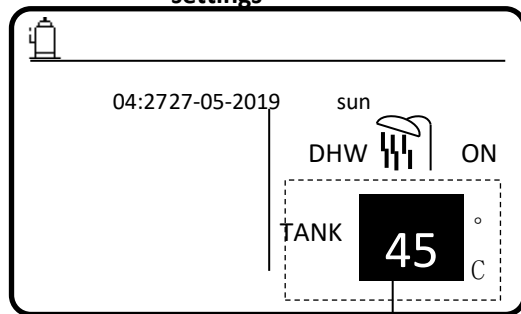

Sets the desired water tank temperature, ranging from 25 C to 80 C.

High Temperature Hydro Module

Heat Mode and DHW Mode

Midea V6R High Temperature Hydro Module

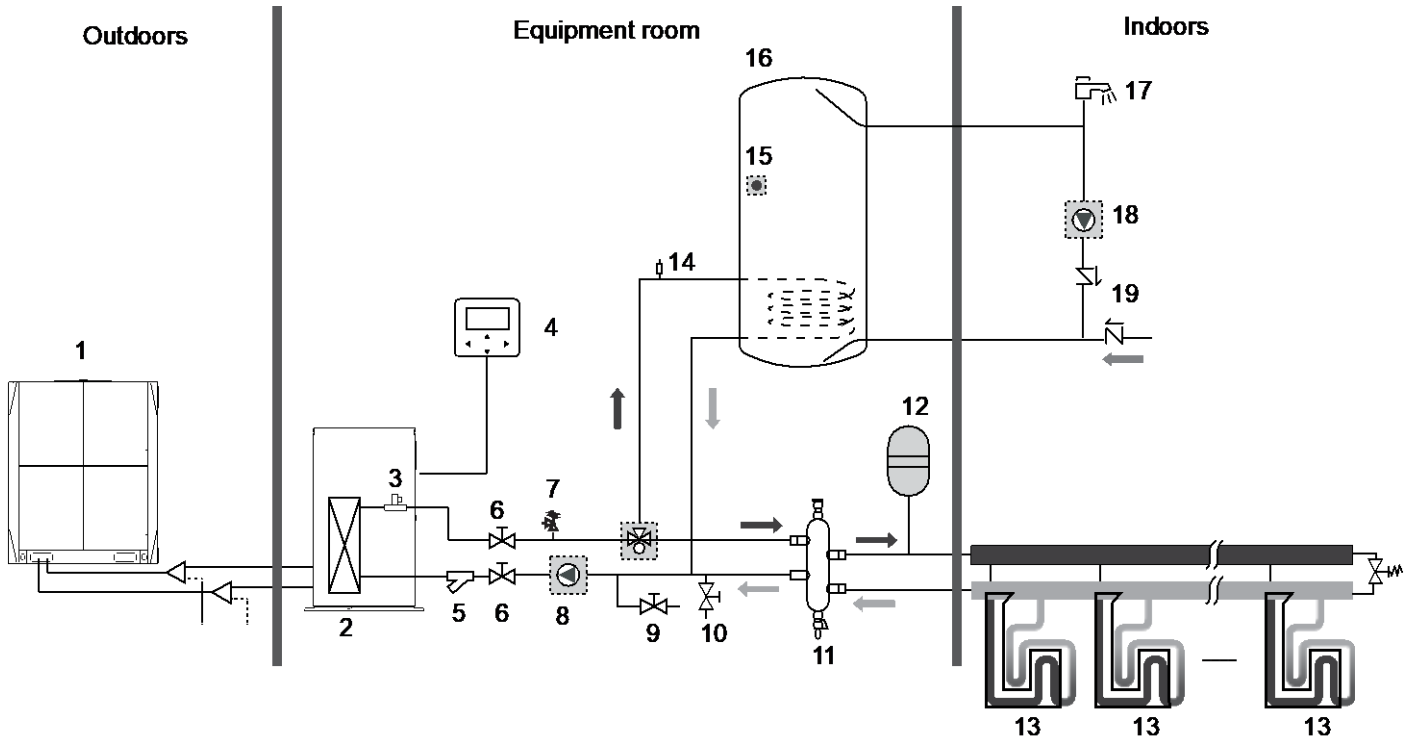

1	ODU
2	Hydro module
3	Water flow switch
4	Wired controller (Accessory)
5	Y-shaped filter (Accessory)
6	Check valve (Provided on site)
7	Safety valve (Accessory)
8	Water pump (Provided on site. For model selection, see page 32.)
9	Drain valve (Provided on site)
10	Water replenishing valve (Provided on site)
11	Water collector (Provided on site)
12	Water expansion tank (Provided on site. For model selection, see page 33.)
13	Terminals. The unit can connect to the floor heating device FHL (25 °C-45 °C), fan coil FCU (45 °C-60 °C), and radiator (60 °C-80 °C), which have different temperature requirements.
14	Discharge valve (Provided on site)
15	Water tank (Provided on site)
16	Temperature sensor of the water tank (Accessory)
17	Tap (Provided on site)
18	Water tank and water pump (Provided on site)
19	One-way valve (Provided on site)

Notes for installers and service engineers

Caution

Terminals on the water system side can connect the fan coil (floor heating device/radiator) for heating or a water tank for water heating. Water heating requires the temperature sensor of the water tank provided among accessories to detect

On-site settings of the wired controller:

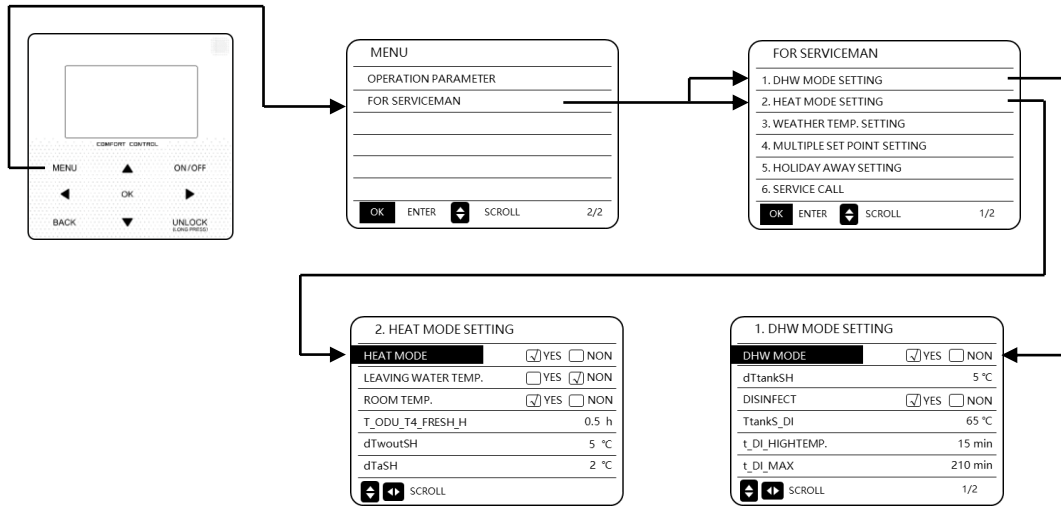

DHW MODE=YES
Heat mode is
invalid.

DHW MODE=YES
DHW mode is
invalid.

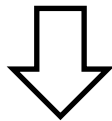

**Temperature
settings**

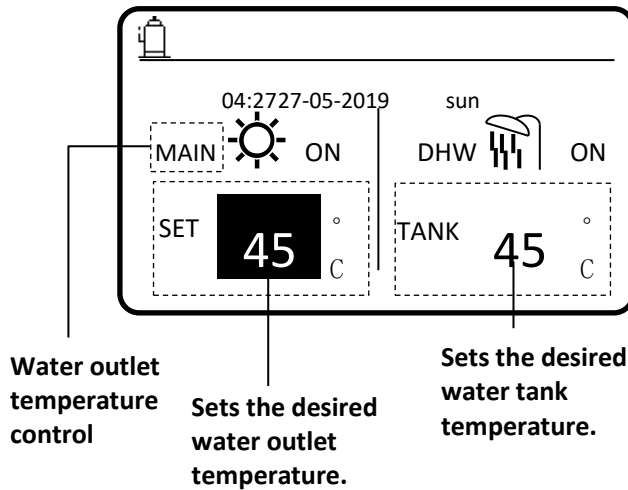

High Temperature Hydro Module

Only heating mode is available and there are multiple set points for heating mode.

Notes for installers and service engineers

Caution

When one hydro module is connected to multiple terminals that have different temperature requirements (such as the floor heating device, fan coil unit, and radiator), you need to use the multiple set point function.

Midea V6R High Temperature Hydro Module

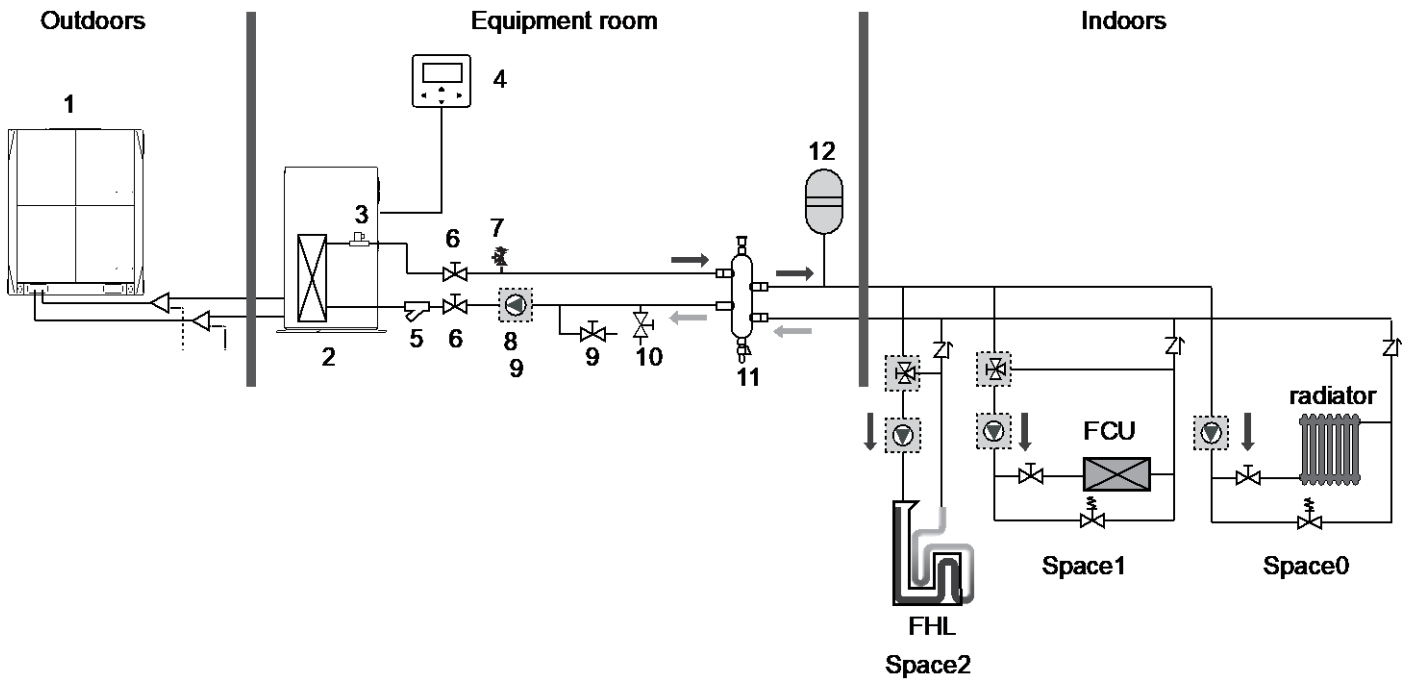

1	ODU
2	Hydro module
3	Water flow switch
4	Wired controller (Accessory)
5	Y-shaped filter (Accessory)
6	Check valve (Provided on site)
7	Safety valve (Accessory)
8	Water pump (Provided on site. For model selection, see page 32.)
9	Drain valve (Provided on site)
10	Water replenishing valve (Provided on site)
11	Water collector (Provided on site)
12	Water expansion tank (Provided on site. For model selection, see page 33.)

Enabling the multiple set point of the wired controller:

- When only heating mode is available, the settings are the same as those described above.
- Multiple set point settings are as follows:

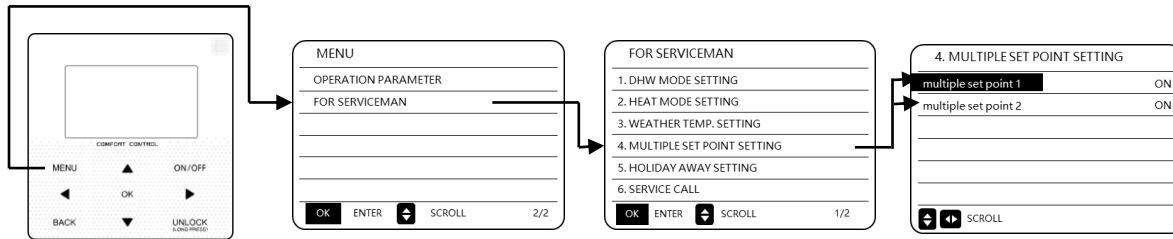

multiple setpoint1=ON: Enable multiple set point 1;
multiple setpoint2=ON: Enable multiple set point 2;

- Temperature settings of multiple set points

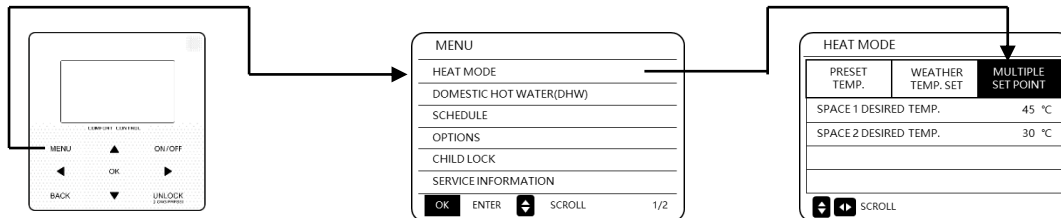

SPACE 1 DESIRED TEMP.: Desired temperature of multiple set point 1;
SPACE 2 DESIRED TEMP.: Desired temperature of multiple set point 2;

No.	Desired temp.	Thermo status			
		space 0	space 1	space 2	Resulting
space 0	a	OFF	ON	OFF	OFF
space 1	b	OFF	ON/OFF	ON	OFF
space 2	c	OFF	ON/OFF	ON/OFF	ON
Resulting desired temp.		OFF	a	b	c

Notes for installers and service engineers

Caution

- space0 can be set on the main interface of the wired controller, while space1 and space2 temperature are set on the HEAT MODE interface
- space0 should be the terminal that requires the highest temperature, while space2 requires the lowest temperature. The temperature required by space1 is between those of space0 and space2. Both space1 and space2 require a temperature reduction device.
- The hydro module controls the water outlet temperature according to the highest required temperature in the event of energy demand availability

Notes for installers and service engineers

Caution

When multiple hydro modules heat water for one water tank, the group control function of the hydro module should be used.

The group control function is only valid to the DHW mode.

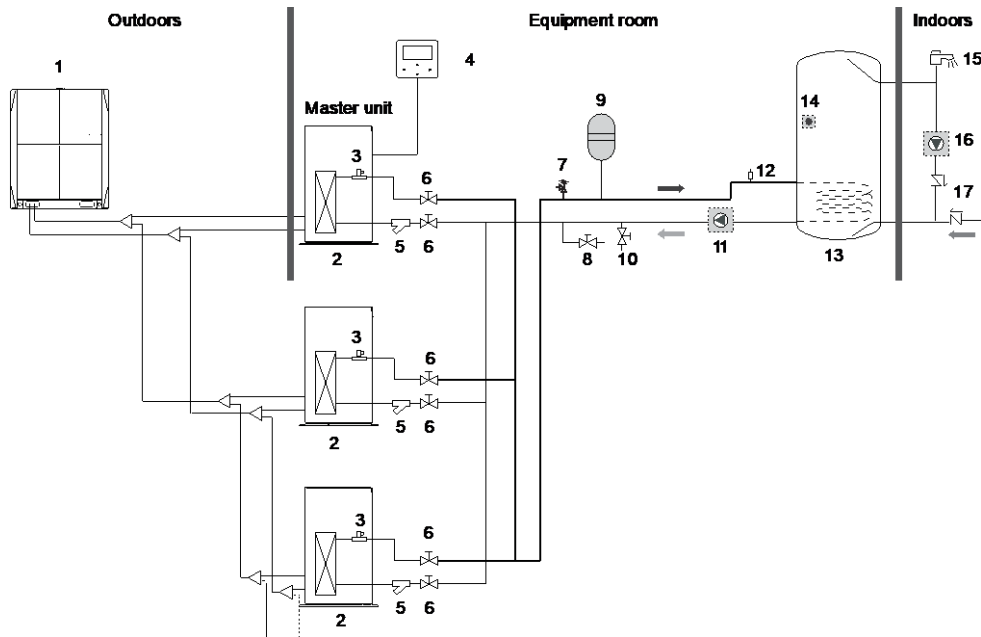

1	ODU
2	Hydro module
3	Water flow switch
4	Wired controller (Accessory)
5	Y-shaped filter (Accessory)
6	Check valve (Provided on site)
7	Safety valve (Accessory)
8	Drain valve (Provided on site)
9	Water expansion tank (Provided on site. For model selection, see page 32.)
10	Water replenishing valve (Provided on site)
11	Water pump (Provided on site. For model selection, see page 33.)
12	Discharge valve (Provided on site)
13	Water tank (Provided on site)
14	Temperature sensor of the water tank (Accessory)
15	Tap (Provided on site)
16	Water tank and water pump (Provided on site)
17	One-way valve (Provided on site)

To enable the group control function, you need to use the following steps to set the DIP switch on the main board: for the master hydro module, turn digit 11; for the slave hydro module, turn digit 10.



Group control function setting:

00 and 01: Group control function is unavailable.

11: Group control function is available. This hydro module is a master hydro module.

10: Group control function is available. This hydro module is a slave hydro module.

Notes for installers and service engineers

Caution

- By default, the value is 00, indicating that a controlled group contains only one master unit.
- The master unit must be connected to a wired controller. The wired controller is used to set the desired water tank temperature.
- The slave unit can be connected to or is not connected to a wired controller. The wired controller of the slave unit provides the query function only.
- The pump is controlled by the master unit. The temperature sensor of the water tank is connected to the master unit.
- The wired controller is connected to the master unit is used to set the desired water tank temperature.

Temperature settings for the wired controller of the master unit:

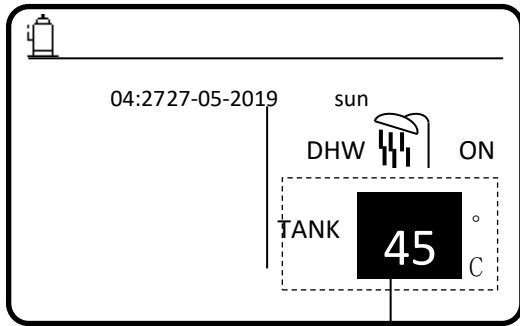

Sets the desired water tank temperature, ranging from 25 C to 80 C.

Notes for installers and service engineers

Caution

- When the water system side of multiple hydro modules are connected in parallel and heat water for a single water tank, you need to set master and slave hydro modules. The temperature sensor of the water tank is connected to the master hydro module and the master hydro module sends the water tank temperature to the slave hydro module.
- Only the wired controller connected to the master unit can be used to set the desired water tank temperature. The master unit is used to control the switch of the circulating water pump.
- In all the preceding installation scenarios, it is recommended that the automatic air discharge valve should be installed at the highest point of the water system.

10 Pump Model Selection

- The water pump should meet the flow requirements of the hydro module. The rated flow of the hydro module is 2.4 m³/h, while the allowed flow range is [1.2, 2.9] m³/h.
- The water pump model is based on the calculation of the water resistance and pipe resistance of the hydro module. The hydro module fluid pressure is as shown in the following figure.

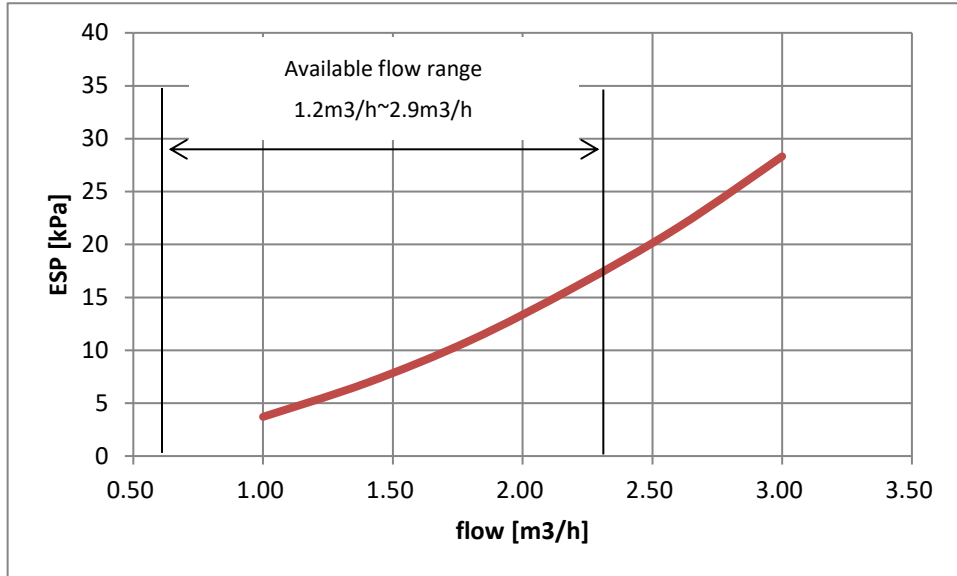

For example:

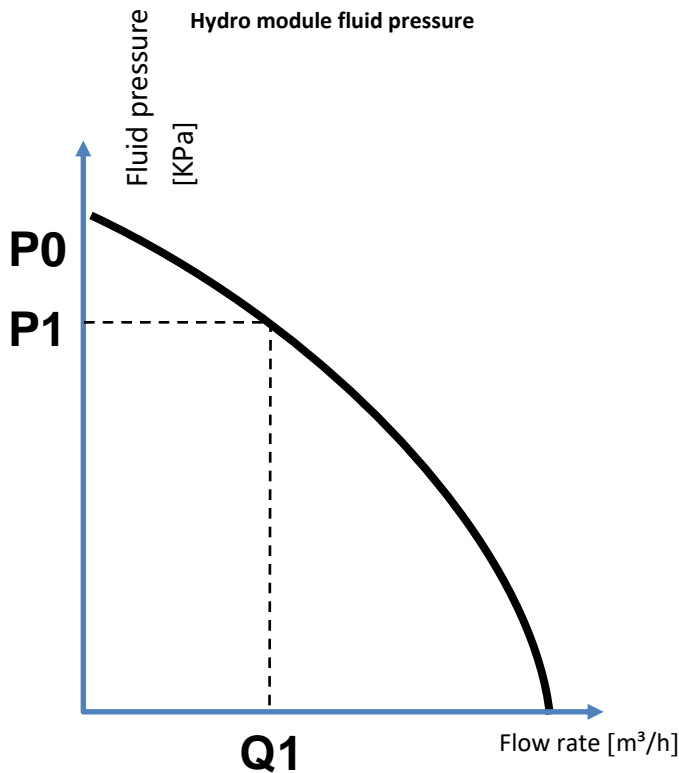

Assume that the performance curve of the selected water pump is as shown in the black figure. When total water resistance in the water system is P₁, the flow rate is Q₁. When Q₁ is within the allowed range of the hydro module, the water pump is suitable. When Q₁ is greater than 2.9 m³/h, water pump capacity can be decreased. When Q₂ is less than 1.2 m³/h, the water pump capacity should be increased.

11 Selection of Expansion Tank Volume and Preset Pressure

- Calculating the preset pressure of the expansion tank

$$Pg = \frac{H}{10} + 0.3 \text{ bar}$$

H—The highest point of the water system is higher than the hydro module.

If Pg is less than the initially preset pressure of the expansion tank, you do not need to adjust the preset pressure of the expansion tank. In general, the initially preset pressure of the expansion tank is 1.5 bar.

- Calculating the minimum volume of the expansion tank

$$V = 0.0693 * V_{\text{water}} / (2.5 - Pg)$$

V_{water} —Total water volume of the water system

Example 1: Total water volume of the water system of a project is 200 L. The highest point of the water system is 12 m higher than the hydro module. Calculate the preset pressure and volume of the expansion tank.

Answer: The preset pressure of the expansion tank is $12 / 10 + 0.3 = 1.5$ bar. The required minimum volume of the expansion tank is $V = 0.0693 * 200 / (2.5 - 1.5) = 13.86$ L.

Example 2: Total water volume of the water system of a project is 72 L. The highest point of the water system is 0 m higher than the hydro module. Calculate the preset pressure and volume of the expansion tank.

Answer: The preset pressure of the expansion tank $Pg = 0 / 10 + 0.3 = 0.3$ bar, which is 1.5 bar less than the initially preset pressure of the expansion tank. The required minimum volume of the expansion tank is $V = 0.0693 * 72 / (2.5 - 1.5) = 4.98$ L.

12 Domestic hot water tank

A domestic hot water tank (with or without booster heater) can be connected to the unit. The requirement of the tank is different for different unit and material of heat exchanger.

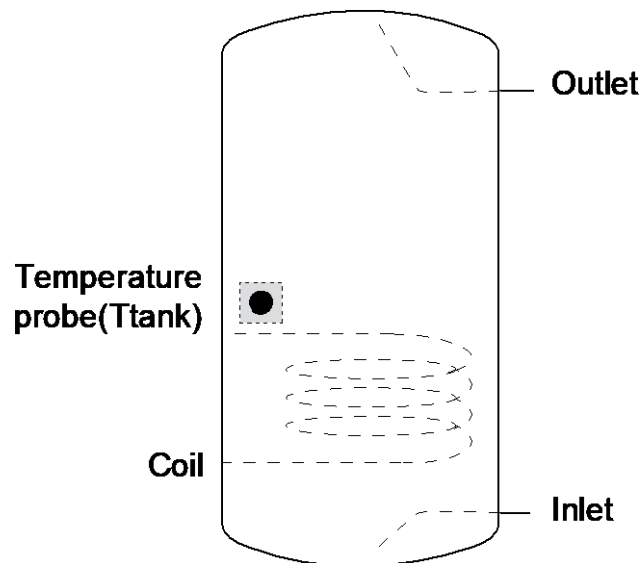

If the tank volume is greater than 240L, the temperature probe (T_{Tank}) should be installed at a position higher than half of the tank's height.

If the tank volume is less than 240L, the temperature probe should be installed at a position higher than 2/3 of the tank's height.

If the booster is installed, the booster heater should be installed below the temperature probe.

The heat exchanger (coil) should be installed below the temperature probe.

The pipe length between the hydro module and tank should be less than 5 meters.

13 Final Check and Test Run

13.1 Final Check

Before closing the switch of the unit, please read the following information:

- When you complete installation of the unit and have performed all the necessary settings, ensure that all the metal plates are closed. This can protect you from electrical parts and high-temperature parts inside the unit.
- The electric control box cover plate can only be opened by an electrician who is certified for maintenance.
- Discharge air in the system.

13.2 Test Run

Test run is described on the installation manual of the ODU. This is an automatic test run, which will last for more than 1 hour.

14 Piping Design

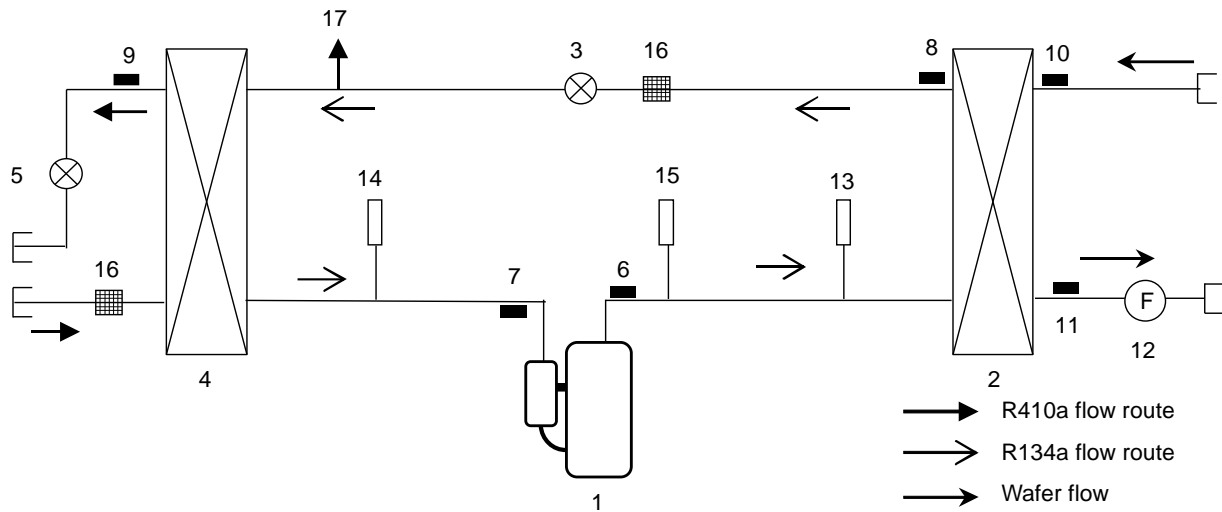

NO.	Description	
1	Compressor	/
2	R134a to water Plate heat exchanger	/
3	Electronic expansion valve 1	EEV1
4	R410a to R134a Plate heat exchanger	/
5	Electronic expansion valve 2	EEV2
6	Discharge pipe temperature sensor	T7C
7	Suction pipe temperature sensor	T7
8	R134a circle liquid pipe temperature sensor	T3
9	R410a circle liquid pipe temperature sensor	T2A
10	Water inlet temperature sensor	Twin
11	Water outlet temperature sensor	Twout
12	Flow switch	FS
13	High pressure sensor	H-YL
14	Low pressure sensor	L-YL
15	High pressure switch	H-Pro
16	strainer	/
17	Service port	/

Key components:

1. Compressor: Drive R134a coolant flow
2. R134a to water Plate heat exchanger :
3. Electronic expansion valve 1: Control R134a refrigerant circulation flow
4. R410a to R134a Plate heat exchanger : Heat transfer between R410a and R134a refrigerants
5. Electronic expansion valve 2: Control the R410a coolant flow of the hydro module

15 Wiring Diagram

Figure 9.1: Power and communication wiring

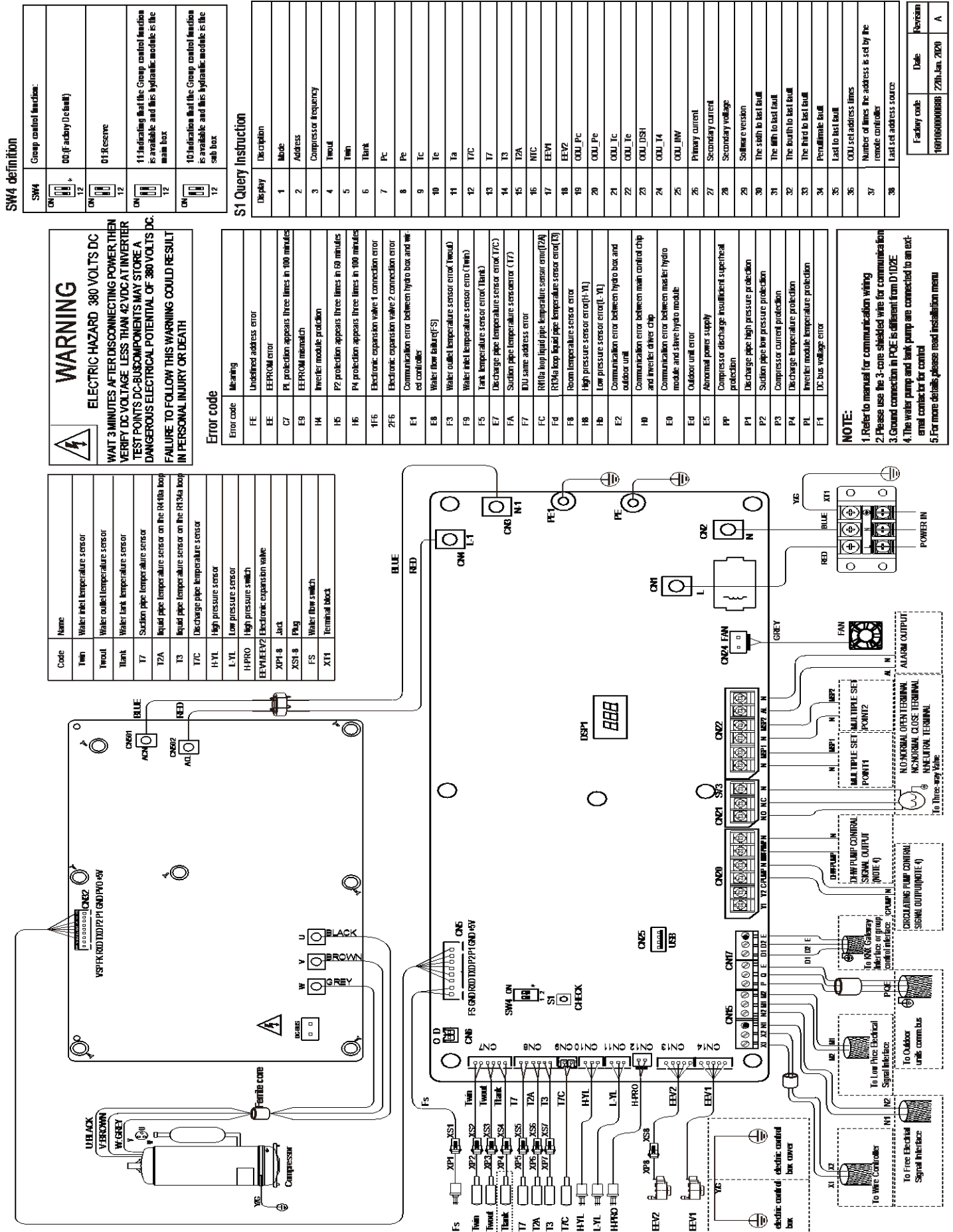

16 Sound Levels

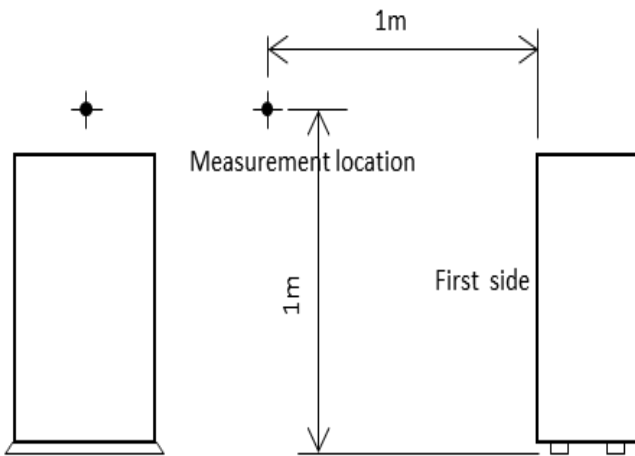







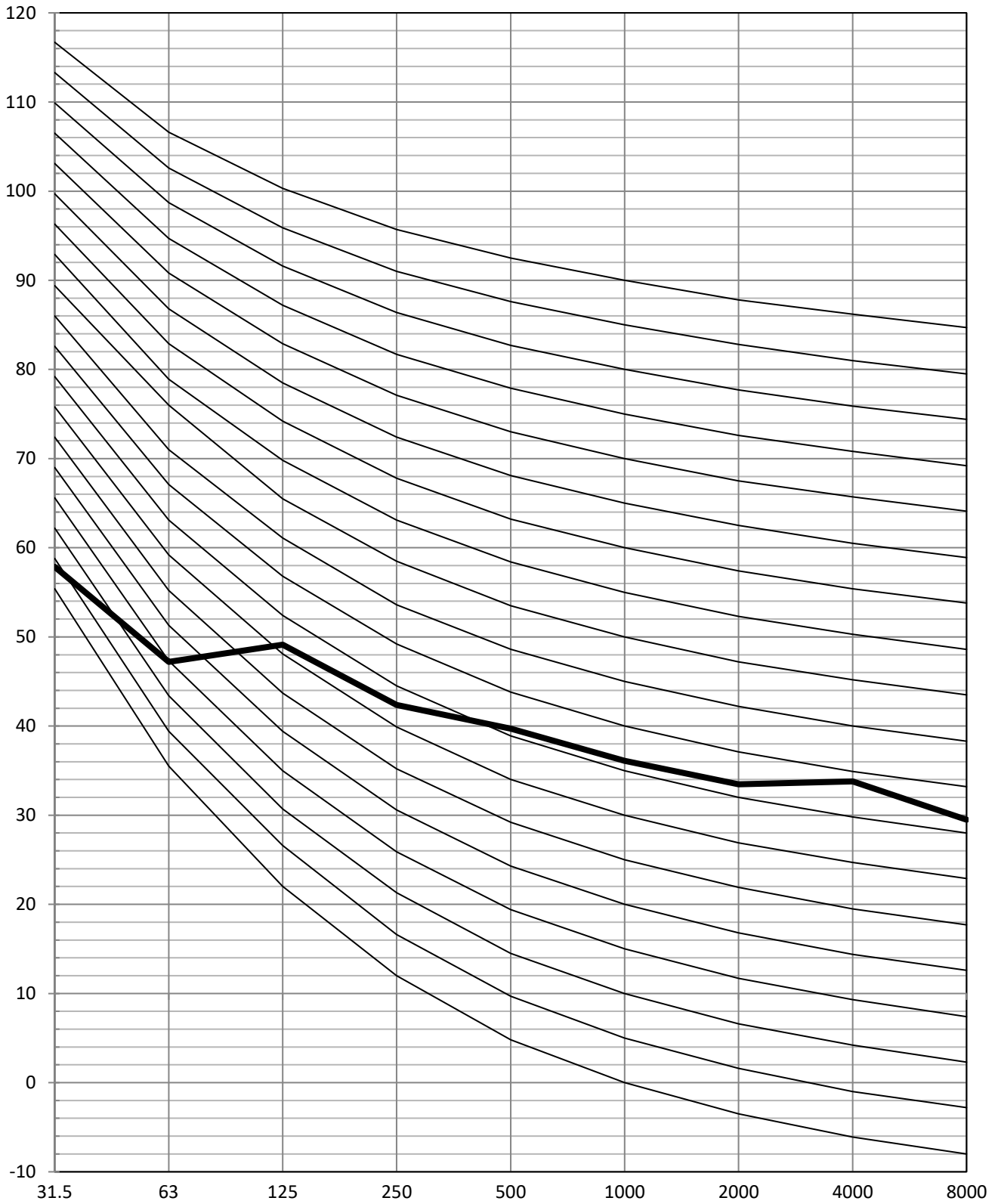

Notes:

- Sound measured at 1.0m away from the center of the unit.
- Data is valid at free field condition
- Data is valid at nominal operating condition
- Sound level will vary depending on a range of factors such as the construction (acoustic absorption coefficient) of particular room in which the equipment is installed.
- Condition: rated heating condition
 Inlet water Temp. : 40°C
 Outlet water Temp. : 45°C
 Water flow rate : 2.4 m³/h
 Outdoor Temp. : 7 °C/6°C (DB/WB)

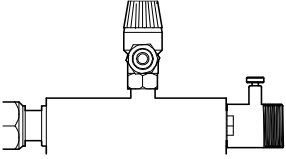
Sound pressure level	Nom.	dB (A)	43
Sound Power Level	Nom.	dB (A)	54

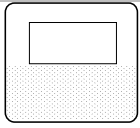

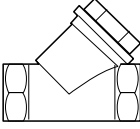
17 Accessories

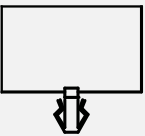
Installation Manual	1		—————
User Manual	1		—————
Connecting pipe assembly (Including safety valve)	1		Connected to the water-outlet pipe side
Water discharge hose	1		Connected to the outlet of the drainage pan
Wired controller	1		To control the unit
Water temperature sensor	1		For detecting water tank temperature
Y-shaped filter	1		Connected to the water-inlet pipe side
Network Matching Wire	2		—————
Cable tie	6		Fixing the wire and magnetic ring
Magnetic ring	2		—————